

Edition 1.02  
16.10.03

## **Standard**

# **Electronic Chart Display and Information System for Inland Navigation**

## **Inland ECDIS**

**Date of print: 28.03.04**

## Content

	Page
Preface	
Structure of the Standard	
Comparison of the structure of the standards for (Maritime) ECDIS and Inland ECDIS	
Section 1      Performance standard.....	1
Section 2      Data standard.....	11
Appendix A    Object catalogue.....	15
Annex A      Codes for producers and waterways .....	103
Appendix B    Product specification .....	105
Annex A      Use of the object catalogue .....	111
Section 3      Presentation standard .....	129
Appendix A    Presentation library.....	133
Section 4      Operational and performance requirements, .....	157
test methods and required test results	
Appendix A    Measures to ensure software quality.....	173
Appendix B    System configurations .....	181
Section 5      Glossary of terms .....	185

## Preface

Reflections and experiments have been made in several countries of the European Union (EU) to use telematics for the support of inland navigation. This aim was especially pursued in the scope of the EU research and development project INDRIS. A pilot project on the Rhine river was started in Germany in 1998 under the name of ARGO. In ARGO and INDRIS, the radar image on the display in the skipper's wheelhouse is overlaid by an electronic chart. This is an approach to higher safety and more efficiency of inland navigation.

It turned out in the discussions that only an internationally agreed procedure will be successful, since a skipper cannot be expected to employ different equipment in each country. This was the reason why the internationally introduced *Electronic Chart Display and Information System (ECDIS)* - originally developed for maritime navigation - was also considered for inland navigation. The latest versions of the IMO, IHO and IEC standards for ECDIS were introduced in 1996. ECDIS is a well matured system now. The idea was to adopt ECDIS for inland navigation and to supplement some distinct inland features, but not to change the original ECDIS standard. In this way, it will be possible to have compatibility between the original - Maritime - ECDIS and Inland ECDIS. This is important for the estuaries of the rivers, where sea vessels as well as inland vessels navigate.

The *Concerted Action on Inland Navigation*, an institution of the 4<sup>th</sup> Framework Programme for Transport Research and Development of the European Union, appointed a Working Group and an Inland ECDIS Expert Group in 1998 with the development of an Inland ECDIS Standard. The experience of ARGO and INDRIS had to be taken as the basis for the new standard.

The Expert Group had the following members:

- Mr. Christian Krajewski (chairman), Mr. Kersten Gevers, Mr. Eric Rottmann, Mr. Hermann Haberkamp, Dr. Arne Driescher (from 2000), Dr. Reinhard Zimmermann (until 1999) of Germany,
- Mr. Peter Kluytenaar (deputy chairman), Mrs. Lea Kuiters, Mr. Ron Wardenier (until 2000) of The Netherlands and
- Mr. Bernd Birkhuber of Austria.

The Expert Group submitted its first proposal on 1 January 1999.

In the year 2000, the competent committees of the Central Commission for the Navigation on the Rhine (CCNR) in Strasbourg installed an Ad-hoc Working Group for Inland ECDIS with the order to draft the Inland ECDIS Standard of CCNR.

The CCNR Ad-hoc Working Group had the following members:

- Mr. Max Bühler (chairman) and Mr. Peter Sauter of Switzerland,
- Mr. Hermann Haberkamp, Mr. Christian Krajewski, Mr. Konrad Steinkämper and Mrs. Claudia Oberheim of Germany,
- Mr. Alfons Van Reusel of Belgium
- Mr. Jean-Pierre Saunier, Mr. Alberto Dos Santos and Mr. André Kanschine of France,
- Mr. Nico Koedam, Mr. Peter Stuurman and Mr. Cas Willems of The Netherlands,
- Mr. Reinhard Vorderwinkler of Austria and
- Mr. Volker Orlovius (Chief Engineer) of the CCNR.

The Ad-hoc Working Group started with the results of the Expert Group as the basis for their further work.

Since the 4<sup>th</sup> Framework Programme of the European Union ended in the year 2000, the Expert Group reported to the Ad-hoc-Working Group of CCNR afterwards.

Strasbourg, 6 April 2001

Christian Krajewski

Chairman of the Expert Group

Max Bühler

Chairman of the Ad-hoc Working Group

Volker Orlovius

Chief Engineer of CCNR

### Structure of the Inland ECDIS Standard

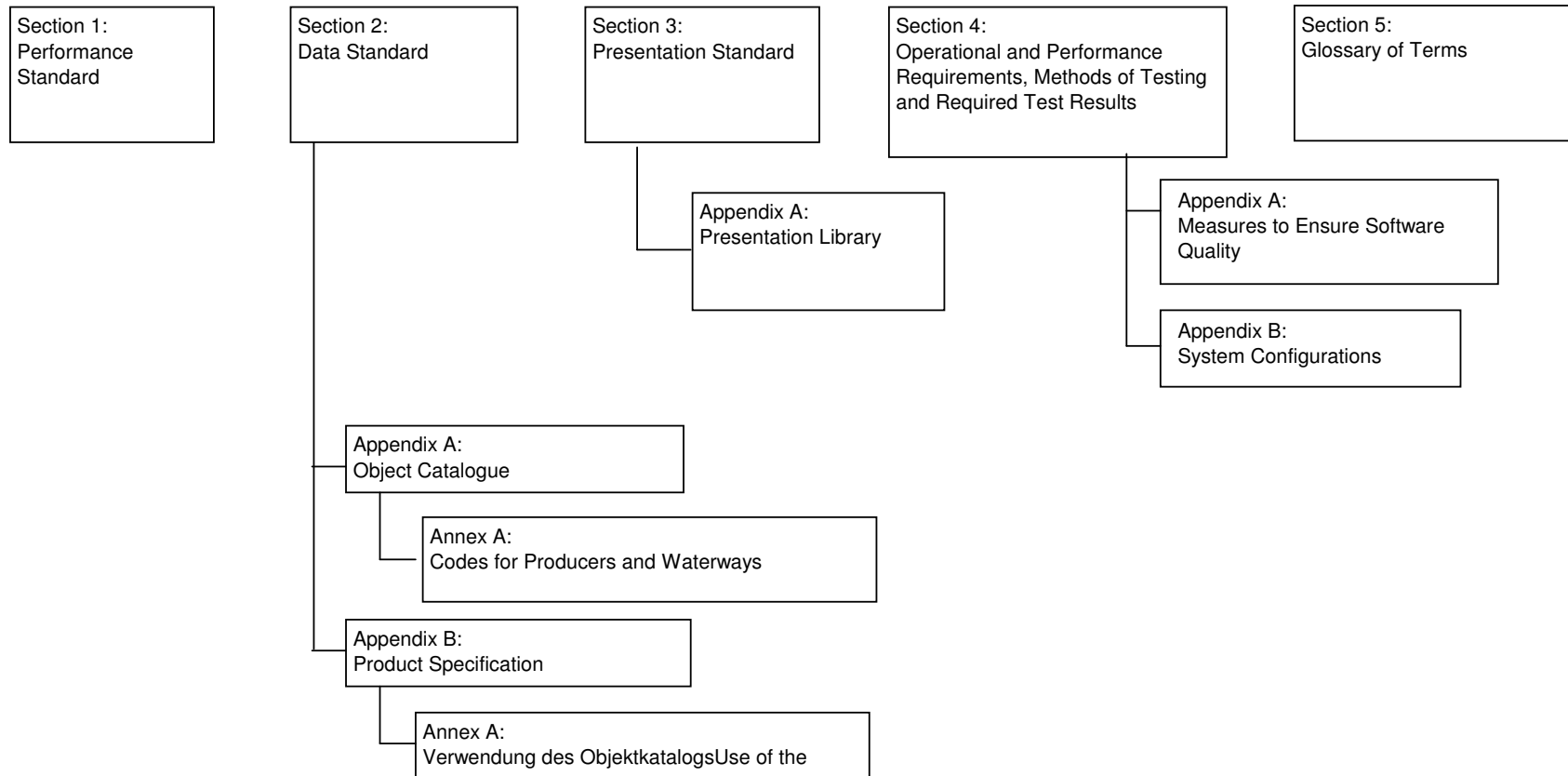

**Comparison of the structures of the standards for (Maritime) ECDIS and Inland ECDIS**

**(Maritime) ECDIS**

**Inland ECDIS (Edition 1.02, 16.10.2003)**

**IMO A.817(19)** Performance Standards for ECDIS, November 1995  
 Appendix 1: Reference Documents  
 Appendix 2: SENC Information  
 Appendix 3: Navigational Elements and Parameters  
 Appendix 4: Areas for which special conditions exist  
 Appendix 5: Alarms and Indicators

**Section 1:** Performance Standard

**IHO S-57:** Transfer Standard for Digital Hydrographic Data, Edition 3.0, November 1996

**Section 2:** Data Standard

Part 1: General Introduction  
 Part 2: Theoretical Data Model  
 Part 3: Data Structure

Appendix A: IHO Object catalogue  
 Introduction  
 Chapter 1: Object Classes  
 Chapter 2: Attributes

Appendix A: Object Catalogue  
 1: Introduction  
 2 - 4: Object Classes  
 5 - 6 : Object Attributes

Annex A: IHO Codes for Producing Agencies  
 Annex B: Cross Reference

Annex A: Codes for Producers and Waterways

Appendix B: Product specifications  
 Appendix B.1: ENC Product Specification  
     Annex A: Use of The Object Catalogue for ENC  
     Annex B: Example of CRC Coding  
 Appendix B.2: Data Dictionary Product Specification

Appendix B: Product Specification  
 Annex A: Use of the Object Catalogue

**IHO S-52** Specification for Chart Content and Display Aspects of ECDIS, Edition 5, December 1996

**Section 3:** Presentation Standard

Appendix 1: Guidance on Updating the ENC  
 Annex A: Defination and Acronyms  
 Annex B: Current Updating Practice for Paper Charts  
 Annex C: Estimate of Data Volume

Appendix 2: Colour & Symbol Specifications for ECDIS  
 Annex A: IHO ECDIS Presentation Library  
     Part I: Use of the Presentation Library  
     Part II: Mariners Navigation Objects  
     Part III: Supplementary Features  
 Annex B: Calibration of Colour CRTs  
 Annex C: Maintaining the Calibration of Colour CRTs

Appendix A: Presentation Library

Appendix 3: Glossary of ECDIS-Related Terms

**IEC 1174:** ECDIS - Operational and Performance Requirements, Methods of Testing and Required Test Results, December 1996

**Section 4:** Operational and Performance Requirements, Methods of Testing and Required Test Results

Appendix A: Software Quality Assurance  
 Appendix B: System Configurations

**Section 5:** Glossary of Terms

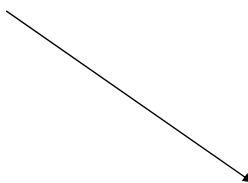

Edition 1.02  
16.10.2003

## **Standard**

# **Electronic Chart Display and Information System for Inland Navigation**

## **Inland ECDIS**

---

---

### **SECTION 1**

---

---

# **Performance Standard for Inland ECDIS**

## Contents

<b>1</b>	<b>Introduction (Primary Functions and Performance)</b> .....	<b>3</b>
<b>2</b>	<b>Definitions</b> .....	<b>4</b>
2.1	Terms .....	3
2.2	References .....	4
<b>3</b>	<b>Contents, Provision and Updating of Chart Information</b> .....	<b>4</b>
3.1	Contents and provision of Inland ENC's .....	4
3.2	Updates .....	5
<b>4</b>	<b>Presentation of Information</b> .....	<b>5</b>
4.1	Display requirements .....	5
4.2	Display ranges (scales) .....	6
4.3	Image positioning and orientation .....	6
4.4	Display of SENC information .....	6
4.5	Display of radar information.....	7
4.6	Display of other navigational information .....	7
4.7	Colours and symbols .....	7
4.8	Data and display accuracy .....	7
<b>5</b>	<b>Operation</b> .....	<b>8</b>
5.1	Information mode.....	8
5.2	Navigation mode.....	8
5.3	Operation controls .....	9
<b>6</b>	<b>Connections with other Equipment</b> .....	<b>9</b>
<b>7</b>	<b>Indications and Alarms</b> .....	<b>9</b>
7.1	Built in Test Equipment (BITE) .....	9
7.2	Malfunctions .....	9
<b>8</b>	<b>Fall Back Arrangements</b> .....	<b>9</b>
8.1	Insufficient accuracy of the SENC-positioning .....	9
8.2	Defects.....	9
<b>9</b>	<b>Power Supply in Navigation Mode</b> .....	<b>10</b>



## 1 Introduction (Primary Functions and Performance)

- a) Inland ECDIS shall contribute to safety and efficiency of inland shipping and thereby to protection of the environment.
- b) Inland ECDIS shall reduce the navigational workload as compared to traditional navigation and information methods.
- c) Inland ECDIS (Operating System Software, Application Software and Hardware) shall have a high level of reliability and availability at least of the same level as other means of navigation, for the navigation mode as specified in Section 4 of this standard.
- d) Inland ECDIS can be designed for information mode only or for both, information mode and navigation mode.
- e) Inland ECDIS shall use chart information as specified by Sections 2 and 3 of this Standard.
- f) Inland ECDIS shall facilitate simple and reliable updating of the Inland ENC.
- g) Inland ECDIS shall provide appropriate alarms or indications with respect to the information displayed or malfunction of the equipment.
- h) Inland ECDIS shall meet the requirements of this performance standard.

## 2 Definitions

### 2.1 Terms (see also section 5 of this Standard: Glossary)

For the Inland ECDIS performance standard the following definitions apply:

- a) **Inland ECDIS** means an electronic chart display and information system for inland navigation, displaying selected information from an Inland System Electronic Navigational Chart (Inland SENC) and, optionally, information from other navigation sensors.
- b) **Inland Electronic Navigational Chart (Inland ENC)** means the database, standardised as to content, structure and format, issued for use with Inland ECDIS. The Inland ENC complies with the IHO standards S-57 and S-52, enhanced by the additions and clarifications of this standard for Inland ECDIS. The Inland ENC contains all essential chart information and may also contain supplementary information that may be considered as helpful for navigation.
- c) **Inland System Electronic Navigational Chart (Inland SENC)** means a database, resulting from the transformation of the Inland ENC by Inland ECDIS, for appropriate use, updates to the Inland ENC by appropriate means and other data added by the skipper. It is this database that is actually accessed by the Inland ECDIS for display generation and other navigational functions. The Inland SENC may also contain information from other sources.
- d) **Minimum Information Density (display base)** means the minimum amount of SENC information that is presented and which cannot be reduced by the operator, consisting of information that is required at all times in all geographic areas and under all circumstances.

- e) **Standard Information Density (standard display)** means the default amount of SENC information that shall be visible when the chart is first displayed on Inland ECDIS first.
- f) **All Information Density (all display)** means the maximum amount of SENC information. Here, in addition to the standard display, also all other objects are displayed, individually on demand.
- g) **User-defined settings** means the possibility to use and store a profile of display and operation controls-settings.
- h) **Integrated Display** means a head-up, relative-motion picture consisting of the SENC overlaid with the radar-image with matching scale, offset and orientation.
- i) **Navigation Mode** means the use of the Inland ECDIS for conning the vessel with overlaid radar image.
- j) **Information Mode** means the use of the Inland ECDIS for information purposes only without overlaid radar image.

## 2.2 References

- a) IHO Special Publication No. S-57 "IHO Transfer Standard for Digital Hydrographic Data", 3<sup>rd</sup> Edition, November 1996
- b) IHO Special Publication No. S-52 "Specifications for Chart Content and Display Aspects of ECDIS", 5<sup>th</sup> Edition, December 1996, including
  - S-52 Appendix 1 "Guidance on Updating the Electronic Chart", 3<sup>rd</sup> Edition, July 1997,
  - S-52 Appendix 2 "Provisional Colour and Symbol Specifications for ECDIS", 1<sup>st</sup> Edition, February 1991 and
  - S-52 Appendix 3 "Glossary of ECDIS-related Terms", 2<sup>nd</sup> Edition, September 1993
- c) IMO Resolution A.817(19) "Performance Standards for Electronic Chart Display and Information Systems (ECDIS)", November 1995
- d) IEC-Guideline 1174 "ECDIS -- Operational and performance requirements, methods of testing and required test results", December 1996
- e) ZKR-Beschlüsse 1989-II-33,- 34 und -35 (Vorschriften betreffend die Mindestanforderungen, die Prüfbedingungen, den Einbau und die Funktionsprüfung von Navigationsradaranlagen und Wendeanzeigern in der Rheinschifffahrt)

## 3 Contents, Provision and Updating of Chart Information

### 3.1 Contents and Provision of Inland ENCs

- a) The chart information to be used in Inland ECDIS shall be the latest edition of information.
- b) Provisions shall be made to prevent the user from altering the contents of original Inland ENC editions.
- c) If the chart is intended to be used for navigation mode (Ch. 5.2), at least the following objects shall be included in the ENC:

- bank of waterway (at mean water level)
  - shoreline construction (groyne, longitudinal control dam)
  - contours of locks and dams
  - boundaries of the fairway (if defined)
  - isolated dangers in the fairway under water
  - isolated dangers in the fairway above water level, such as bridges, overhead wires etc.
  - buoys, beacons, lights, notice marks
  - waterway axis with kilometres and hectometres
- d) If the chart is intended to be used for navigation mode (ch 5.2), the government-authorised authority decides for each waterway which of the above named objects are to be verified by the authority.

### **3.2 Updates**

- a) Inland ECDIS shall be capable of accepting updates to the Inland ENC data provided in conformity with the agreed standards. These updates shall be applied to the SENC automatically. The implementation procedure shall not interfere with the display in use.
- b) Inland ECDIS shall allow display of updates, so that the skipper may review their contents and ascertain that they have been included in the SENC.
- c) Inland ECDIS shall be capable of revoking automatically applied updates of the Inland ENC data.
- d) Original Inland ENC editions and later updates shall never be merged.
- e) The Inland ENC and all updates to it shall be displayed without any degradation of their information content.
- f) The Inland ENC data and updates to it shall be clearly distinguishable from other information.
- g) Inland ECDIS shall ensure that the Inland ENC and all updates to it have been correctly loaded into the SENC.
- h) Inland ECDIS shall keep a record of updates, including the time of application to the SENC.
- i) The contents of the SENC to be used shall be adequate and up to date for the intended voyage.

## **4 Presentation of Information**

### **4.1 Display Requirements**

- a) The display method shall ensure that the displayed information is clearly visible to more than one observer in the typical conditions of light experienced in the wheelhouse of a vessel by day and night.
- b) The display size of the chart presentation shall be at least 270 mm by 270 mm for equipment designed and admitted for the Navigation Mode. In Information Mode ergonomic aspects shall determine the size.
- c) The display requirements shall be met whether in landscape or in portrait format.

## 4.2 Display Ranges (Scales)

- a) In Information Mode (ref. to Ch. 5.1), it is recommended to use the same ranges as specified in the Navigation Mode.
- b) In Navigation Mode (ref. to Ch. 5.2), only the successive switchable ranges (scales) specified in Section 4, ch.4.7 of this Standard are allowed.

## 4.3 Image Positioning and Orientation

- a) In Information Mode all kinds of chart orientation are allowed (see Ch. 5.1)
- b) In Navigation Mode the chart shall be automatically positioned and oriented in the relative motion, head-up orientation with the own ship's position in the screen centre or off-centred (see Ch. 5.2).

## 4.4 Display of SENC Information

- a) The display of SENC information shall be divided into the following three display categories:
  - Display Base
  - Standard Display
  - All Information Display

The membership of the object classes in the display categories is given in detail in the Look-up Tables of IHO S-52, Appendix 2, Annex A (Presentation Library) and in Section 3, Appendix A (Presentation Library) of this Standard.

- b) The Display Base category has to contain at least the following objects:
  - river bank (at mean water level)
  - shoreline construction (groyne, longitudinal control dam)
  - contours of locks and dams
  - boundaries of the fairway (if defined)
  - isolated dangers in the fairway under water
  - isolated dangers in the fairway above water level, such as bridges, overhead wires etc.
  - buoys, lights and beacons
- c) The Standard Display category has to contain at least the following objects:
  - the objects of Display Base category
  - prohibited and restricted areas
  - piers for commercial vessels (cargo and passenger)
  - kilometre and hectometre marks on the banks
- d) The All Information Display category has to display all objects that are contained in the Inland SENC, individually on demand.
- e) When invoking the Inland ECDIS, it shall come up with the Standard Information Density at an appropriate range available in the SENC for the displayed area
- f) Inland ECDIS shall be switchable to the Standard Information Density at any time by a single operator action.

- g) Inland ECDIS shall clearly indicate the information density currently in use at all times.
- h) Time variable depth information in the ENC has to be displayed independently of the above named three display categories.

#### **4.5 Display of Radar Information**

- a) In Navigation Mode the radar image shall have the highest display priority and it is only allowed to be presented in the relative motion, head-up mode.
- b) The overlaid SENC shall match in position, range and orientation. The radar image and the position from the position sensor shall both be adjustable for the antenna offset to the conning position.
- c) The overlaid radar image has to conform with the minimum requirements as specified in Section 4, ch. 4.14 of this Standard.
- d) The overlaid radar-image may contain additional navigational information.

#### **4.6 Display of Other Navigational Information**

- a) Inland ECDIS and additional navigational information shall use a common reference system.
- b) It shall be possible to display the skipper's own ship's position on the screen.
- c) It shall be possible for the skipper to select safety limits.
- d) Inland ECDIS shall emphasize the falling short of the safety limits.

#### **4.7 Colours and Symbols**

- a) The display of colours and symbols to represent SENC information shall comply with the regulations of Section 3 of this Standard.
- b) To present navigational elements and parameters as listed in the IMO Resolution A.817(19), Appendix 3 other colours and symbols than those mentioned in 4.7.a must be used.

#### **4.8 Data and Display Accuracy**

- a) The accuracy of the calculated data that are presented shall be independent of the display characteristics and shall be consistent with the SENC accuracy.
- b) The Inland ECDIS shall provide an indication whether the display uses a smaller display range than the accuracy of the Inland ENC data offers (over-scale indication).
- c) The accuracy of all calculations performed by Inland ECDIS shall be independent of the characteristics of the output device and shall be consistent with the SENC accuracy.
- d) Bearings and distances drawn on the display or those measured between features already drawn on the display shall have an accuracy no less than that afforded by the resolution of the display.

## **5 Operation**

### **5.1 Information Mode**

- a) Information Mode is intended to be used for information only and not for navigation.
- b) In Information Mode all kinds of chart orientation, rotation, zooming and panning are allowed. However, it is recommended to use the same fixed ranges as in the Navigation Mode and the chart orientation whether
  - to north, or
  - to the fairway axis at the actual position, or
  - to the actual ships-heading.
- c) It should be possible to scroll the chart manually on the screen with the fairway axis in line with the vertical screen axis.
- d) Inland ECDIS may be connected to a positioning sensor to scroll the chart picture automatically and to display the section of chart matching the actual surrounding, namely in the operator-selected range and with the own ship's position to the centre of the screen. The centre line of a river, channel or buoyed route will be assumed as to be decisive for the orientation of the chart.
- e) The skipper's own ship's position should be marked with an appropriate generic symbol.

### **5.2 Navigation Mode**

- a) In Navigation Mode, the Inland ECDIS display shall be integrated with the own ship's radar information. The radar information shall be clearly distinguishable from the SENC information.
- b) The integrated display must be in accordance with the requirements for radar on inland waterways as specified in Section 4, ch. 4.14 of this Standard.
- c) The chart and the radar image must match in size, position and orientation within the limits as specified in Section 4, ch. 3.4 and 8.3.2 of this Standard.
- d) The Integrated Display shall only be presented in the head-up orientation. Other orientations are not permitted.
- e) It shall be possible for the operator to adjust the displayed position of the vessel so that the radar image matches the SENC display.
- f) It shall be possible to remove either the ECDIS or the radar information by a single operator action temporarily.
- g) The vessel's position shall be derived from a continuous positioning system of which the accuracy is consistent with the requirements of safe navigation.
- h) Navigation Mode must provide an indication when the input from the position-fixing system is lost. Navigation Mode shall also repeat, but only as an indication, any alarm or indication passed to it from a position fixing system.
- i) The positioning system and the SENC shall be based on the same geodetic datum.
- j) In navigation mode, the data according to ch. 3.1.c of this standard shall always be visible and shall not be obscured by other objects.

### **5.3 Operation and Control Elements**

- a) Inland ECDIS shall be designed following ergonomic principles for user-friendly operation.
- b) The Inland ECDIS equipment shall have a minimum of operation and control elements (see Section 4).
- c) Operation and control elements, and indicators for connected sensors, may be integrated in Inland ECDIS.
- d) Standard settings and user-defined settings shall be retrievable easily.

## **6 Connections with other Equipment**

- a) Inland ECDIS shall not affect the performance of any connected equipment adversely. the connection of optional equipment shall degrade the performance of Inland ECDIS either.
- b) Inland ECDIS shall be capable of generating information to other systems, e.g. for the purpose of electronic reporting.
- c) The relevant requirements of controls and indicators to connected equipment shall be fulfilled.

## **7 Indications and Alarms**

### **7.1 Built in Test Equipment (BITE)**

Inland ECDIS shall be provided with means for carrying out on board tests of major functions either automatically or manually. In case of a failure, the module at fault shall be shown.

### **7.2 Malfunctions**

Inland ECDIS shall provide a suitable alarm or indication of system malfunctions (ref. to Section 4, ch.9).

## **8 Fallback Arrangements**

### **8.1 Insufficient accuracy of the SENC-positioning**

In Navigation Mode the SENC shall be automatically switched off, if the SENC positioning does not match the radar picture within the limits of Section 4, ch. 5.1 and 5.2.

### **8.2 Defects**

- a) If the Inland ECDIS system has an evident defect, it shall provide a suitable alarm (ref. to Section 4, ch. 4.16 and 9 of this Standard).
- b) Facilities enabling a safe take-over of the Inland ECDIS functions shall be provided in order to ensure that an Inland ECDIS failure does not result in a critical situation.

## **9 Power Supply in Navigation Mode**

- a) The Inland ECDIS shall have its own separate fused power supply.
- b) Interruptions of the power supply for a period up to 5 minutes shall not have any influence on correct operation and shall not require restarting of the equipment manually.



Edition 1.02  
16.10.2003

## **Standard**

# **Electronic Chart Display and Information System for Inland Navigation**

## **Inland ECDIS**

---

---

### **SECTION 2**

---

---

## **Data Standard for Inland ECDIS**

## Contents

### Data Standard

Appendix A Annex A	Object Catalogue for Inland ECDIS Codes for Producers and Waterways
Appendix B Annex A	Product Specification for Inland ECDIS Use of the Object Catalogue for Inland ENC

## Data Standard

### 1 Scope

This "Data Standard for Inland ECDIS" describes the standard to be used

- for the exchange of digital hydrographic data between national inland waterway authorities and
- for its distribution to manufacturers, skippers and other users.

This Data Standard shall be used for the production of Inland ECDIS data. The transfer and distribution has to take place in such a way that none of the information is lost.

This Data Standard with its Appendices and Annexes is based on the "IHO Transfer Standard for Digital Hydrographic Data", Special Publication No. 57, Edition 3.0 of November 1996 with all Appendices and Annexes (see table in section 0 of this Inland ECDIS Standard), in brief "S-57".

This Data Standard describes the necessary additions and clarifications to S-57 and the application of S-57 for the purpose of use in Inland ECDIS applications.

### 2 Structure

**Data Standard** gives general regulations and describes the connection to the IHO-document S-57.

**Appendix A** is the "Object Catalogue for Inland ECDIS" which provides the officially approved data scheme to be used to describe entities in the real world. Its Annex A contains the codes producing agencies and waterways.

**Appendix B** contains the "Product Specification for Inland ECDIS". These are additional sets of rules applicable to Inland ECDIS data. Its Annex A contains the description "Use of the Object Catalogue for Inland ENC". Here rules for the encoding of the geometry and semantic descriptions are given.

### 3 Definitions

Definitions of terms may be found in

- S-57, part 1, clause 5
- the "Glossary of ECDIS Related Terms" in Appendix 3 to S-52
- the "Glossary of Terms" in Section 5 of this standard.

## **4 Conformity of data with the standard**

No additions to S-57, part 1, clause 6.

## **5 Maintenance**

Users of the standard, for example equipment manufacturers, must address their comments to the national inland waterways authority.

This standard will be updated by means of the following three documents:

### *Clarifications Document*

This contains improvements to the wording of the standard. These are editorial amendments, which do not result in any substantive change to the standard.

### *Corrections Document*

This contains changes to the standard to correct factual errors and to make necessary amendments to the standard.

### *Extensions Document*

This contains extensions, or other significant changes to the standard, which will be included in the next edition of the standard. This is a working document which is produced and made available only on demand.

## **6 Theoretical Data Model**

The description of the theoretical data model as contained in S-57 Part 2 applies to the theoretical data model of Inland ECDIS without any changes or amendments.

## **7 Data Structure**

The description of the data structure as contained in S-57 Part 3 applies to the data structure of Inland ECDIS without any changes or amendments.

Edition 1.02  
16.10.2003

## **Standard**

# **Electronic Chart Display and Information System for Inland Navigation**

## **Inland ECDIS**

---

---

### **SECTION 2**

---

---

## **Data Standard for Inland ECDIS**

## **Appendix A**

# **Object Catalogue for Inland ECDIS**

in addition to the

IHO-S-57 Object Catalogue

## Contents

<b>1</b>	<b>Introduction.....</b>	<b>18</b>
1.1	The Object Catalogue.....	18
1.2	Extensions of the object classes and attributes.....	21
1.3	Conventions used in this document for types.....	21
<b>2</b>	<b>Geo Object Classes (copied).....</b>	<b>22</b>
	Anchor berth.....	22
	Anchorage area.....	23
	Berth.....	24
	Bridge.....	25
	Cable overhead.....	26
	Canal bank.....	27
	Depth area.....	28
	Distance mark.....	29
	Ferry route.....	30
	Harbour Area.....	31
	Harbour Facilities.....	32
	Lock Basin.....	33
	Radio calling-in point.....	34
	Restricted area.....	35
	River bank.....	36
	Signal station traffic.....	37
	Signal station warning.....	38
	Top Mark.....	39
<b>3</b>	<b>Meta Object Classes (copied).....</b>	<b>40</b>
	Navigational system of marks.....	40
<b>4</b>	<b>Geo Object Classes (new).....</b>	<b>41</b>
	Beacon water-way.....	41
	Bridge area.....	42
	Bunker station.....	43
	Buoy water-way.....	44
	Communication Area.....	45
	Harbour Basin.....	46
	Lock area.....	47
	Lock basin part.....	48
	Notice mark.....	49
	Port Area.....	50
	Refuse dump.....	51
	Route planning point.....	52
	Terminal.....	53
	Turning basin.....	54
	Waterway axis.....	55
	Waterway profile.....	56
<b>5</b>	<b>Object Attributes (copied).....</b>	<b>57</b>
	Category of Anchorage area.....	57
	Category of bridge.....	58
	Category of distance mark.....	59

	Category of ferry .....	60
	Category of harbour facilities .....	61
	Category of signal station traffic .....	62
	Category of signal station warning.....	63
	Marks navigational – System of.....	64
	Restriction.....	65
	Vertical datum.....	66
<b>6</b>	<b>Object Attributes (new) .....</b>	<b>67</b>
	Additional mark.....	67
	Bunker vessel, availability.....	68
	Category of bank .....	69
	Category of berth .....	70
	Category of bunker station.....	71
	Category of CEMT class.....	72
	Category of communication.....	73
	Category of harbour area.....	74
	Category of notice mark .....	75
	Category of refuse dump .....	78
	Category of terminal .....	79
	Category of waterway mark (buoy, beacon) .....	80
	Class of dangerous cargo.....	81
	Communication.....	82
	Direction of impact.....	83
	Distance from bank, first.....	84
	Distance from bank, second.....	85
	Distance of impact, upstream .....	86
	Distance of impact, downstream .....	87
	Elevation 1 .....	88
	Elevation 2 .....	89
	Function of notice mark .....	90
	Horizontal clearance, length .....	91
	Horizontal clearance, width.....	92
	Transshipping goods .....	93
	UN Location Code .....	94
	Update message .....	95
	National update message.....	96
	Waterway distance .....	97
<b>7</b>	<b>Overview of Inland ECDIS Object Classes and Attributes .....</b>	<b>98</b>
<b>8</b>	<b>List of additional used S-57 Object Attributes.....</b>	<b>100</b>

## 1 Introduction

In the S-57 data model hydrographic information is represented as a defined combination of descriptive and spatial characteristics, called 'feature objects' and 'spatial objects'. Details of further classification and relationships can be found in the respective publications of the IHO. In the S-57 standard, the IHO has laid down a data model, an object catalogue, a description of the exchange format and an ENC product specification.

In order to represent data necessary for inland waterway traffic in an application conforming to S-57, the S-57 object catalogue must be enhanced by the required object classes, attributes and values. Such enhancements in terms of 'user defined objects' are allowed in the S-57 standard and there are means to incorporate them.

### 1.1 The Object Catalogue

In the object catalogue, all official IHO object classes along with their allowed attributes and attribute values are defined. The Inland ECDIS object catalogue can be compared to the Chart 1 (INT 1) of the sea charts and additionally contains the special object classes and attributes for inland waterways.

The following types of feature objects exist:

Geo:	descriptive characteristics of the real world
Meta:	additional area related information, e.g. survey source
Collection:	information about relationships between objects



The following example from the object catalogue shows the definition of the S-57 feature object class 'Landmark'

Object class: Landmark	
Acronym: LNDMRK	Code: 74
Set Attribute_A:	CATLMK; COLOUR; COLPAT; CONDTN; CONRAD; CONVIS; ELEVAT; FUNCTN; HEIGHT; NATCON; NOBJNM; OBJNAM; STATUS; VERACC; VERDAT; VERLEN;
Set Attribute_B:	INFORM; NINFOM; NTXTDS; PICREP; SCAMAX; SCAMIN; TXTDSC;
Set Attribute_C:	SORDAT; SORIND;
<u>Definition:</u> A prominent object at a fixed location which can be used in determining a location or a direction. (adapted from IHO Dictionary S-32 5th Edition, 2643).	
<u>References:</u> INT 1: ID 5-6, 13; IE 10.1-20, 22-30.1, 30.3-4, 31; IL 11; IQ 100; M-4: 373.6; 374.1; 374.4; 374.5; 374.6; 374.7; 375.1-2; 375.4; 445.6; 456.2; 487.3;	
<u>Remarks:</u>	
Distinction:	beacon, special purpose/general; building single; daymark; pylon/bridge support; topmark;

### **Example of S57-Object Catalogue (Object Classes)**

Each object class is described by the following entries:

- Object Class: Object class name
- Acronym: 6-Character code of the object class
- Code: Integer code
- Set of attributes:
  - subset 'Attribute-A': individual characteristics of an object
  - subset 'Attribute-B': information about the use of an object
  - subset 'Attribute-C': administrative information on the origin of data
- Definition: Definition
- References:
  - INT 1: to the legend of paper charts
  - M-4: to the IHO-Publication M-4 (Chart Specifications of the IHO)
- Remarks: comments, relationships to other object classes

The following example from the object catalogue shows the definition of the S-57 attribute 'Category of landmark'

Attribute class: Category of landmark		
Acronym: CATLMK		Code: 35
Attribute type: L		
<u>Expected input (value):</u>		
ID	Meaning	INT 1 M-4
1	: cairn	IQ 100; 456.2;
...	: .....	.....;
20	: spire/minaret	IE 10.3, 17;
<u>Definitions:</u>		
cairn:	a mound of stones, usually conical or pyramidal, raised as a landmark or to designate a point of importance in surveying. (IHO Dictionary, S-32, 5th Edition, 601)	
..... : .....		
spire/minaret:	a tall conical or pyramid-shaped structure often built on the roof or tower of a building, especially a church or mosque. (adapted from The New Shorter Oxford English Dictionary, 1993)	
Remarks:	No remarks	

**Example of S-57-Object Catalogue (Attributes)**

Each attribute is described by the following entries:

- Attribute: attribute name
- Acronym: 6-character code of the attribute
- Code: Integer Code
- Attribute type: 1-character code for the data type
- enumerated ('E'): exactly one value selected from a list of pre-defined attribute values
- list ('L'): one or more values selected from a list of pre-defined attribute values
- float ('F'): floating point numeric value
- integer ('I'): integer numeric value
- coded string ('A'): string of ASCII characters in a predefined format
- free text ('S'): free-format alphanumeric string
- Expected input (value): expected input according to the above mentioned input types
- Definitions: Definition
- 
- References:
- INT 1: to the legend of paper charts
- M-4: to the IHO-Publication M-4 (Chart Specifications of the IHO)
- 
- Remarks: Comments, relations to other attributes

## 1.2 Extensions of the object classes and attributes

The extension of existing S-57 object classes with new attributes, and the extension of S-57 attributes with new values are not allowed. Therefore, the S-57 object classes and attributes, which are to be extended according to the requirements of Inland ECDIS, must be copied. Object classes are copied with their complete set of attributes, and attributes are copied with their complete list of attribute values. All new object classes and attributes have the same name as their source but the names are written in lower- case letters.

Reasons for copied object classes:

- Existing object class gets a new attribute, e.g. the object "canal bank" gets the new attribute "category of bank".
- Existing object class gets a copied attribute with new values, e.g. the attribute "category of anchorage area" of the object "anchorage area" gets the new values 10 – 12.
- Existing object class shall be symbolized in another way, e.g. top marks.

Reason for new object classes:

- Real world object can not be transferred into the S-57 world.

Reason for copied attributes:

- A new value is needed for an existing attribute.

Reason for new attributes:

- A new attribute with new values is needed.

Procedure with copied object classes and attributes:

The original object classes (i. e. RESARE) and attributes remain in the Presentation Library in order to enable the presentation of older charts. In the data production for Inland ECDIS only the copied object classes (i. e. resare) and attributes are used.

The Integer Codes for the copied and new object classes and attributes have to be registered at the "Open ECDIS Forum" at [www.openecd.org](http://www.openecd.org)

## 1.3 Conventions used in this document for types

**bold lower case**                      new and copied object classes and attributes,  
   new values to attributes.

UPPER CASE                              old objects and attributes (already existing in S-57 Ed. 3.0 and used  
   without any changes in Inland ECDIS)

**lower case**                              old values to attributes

Object Classes

**COPIED GEO OBJECT CLASS**

Object class	Anchor berth
--------------	--------------

ACRONYM

**achbrt**

Code: **17000**

Set Attribute\_A: **catach; clsdng; comctn;** DATEND; DATSTA; NOBJNM; OBJNAM; PEREND;  
PERSTA; RADIUS; **restrn;** STATUS;

Set Attribute\_B: INFORM; NINFOM; NTXTDS; PICREP; SCAMIN; TXTDSC; **updmsg**

Set Attribute\_C: SORIND; SORDAT

Definition:

A designated area of water where a single vessel, sea plane, etc... may anchor.

References:

INT 1: IN 11.1-2;

M-4: 431.2;

Remarks:

In general the anchor berth is defined by the centre point and a swinging circle.

Distinction: anchorage area; berth; mooring/warping facility;













Object Classes

**COPIED GEO OBJECT CLASS**

Object class	Depth area
--------------	------------

ACRONYM

**depare**

Code: **17003**

Set Attribute\_A: DRVAL1; DRVAL2; **eleva1; eleva2; wtwdis**; QUASOU; SOUACC; **verdat**

Set Attribute\_B: INFORM; NINFOM; NTXTDS; PICREP; SCAMIN; TXTDSC; **updmsg**

Set Attribute\_C: SORIND; SORDAT

Definition:

A depth area is a water area whose depth is within a defined range of values.

References:

Remarks:

Object Classes

**COPIED GEO OBJECT CLASS**

Object class	Distance mark
--------------	---------------

ACRONYM

**dismar**

Code: **17004**

Set Attribute\_A: **catdis**; DATEND; DATSTA; NOBJNM; OBJNAM;

Set Attribute\_B: INFORM; NINFOM; NTXTDS; PICREP; SCAMIN; TXTDSC; **updmsg**

Set Attribute\_C: SORIND; SORDAT

Definition:

A distance mark indicates the distance measured from an origin and consists of either a solid visible structure or a distinct location without special installation. Usually found on canals and rivers.

References:

INT 1: IF 40;

M-4: 361.3; 307;

Remarks:

Distinction: beacon, special purpose;



































Object Classes

**NEW GEO OBJECT CLASS**

Object class	Communication Area
--------------	--------------------

ACRONYM

**comare**

Code: **17055**

Set Attribute\_A:

**catcom**; COMCHA; DATEND; DATSTA; NOBJNM; OBJNAM; STATUS;  
TIMEND

Set Attribute\_B:

INFORM; NINFOM; NTXTDS; PICREP; SCAMIN; TXTDSC; **updmsg**

Set Attribute\_C:

SORIND; SORDAT

Definition:

Indicates the coverage of an area, in which a vessel has to report or may request information.

References:

Remarks:

Distinction:



Object Classes

**NEW GEO OBJECT CLASS**

Object class	Lock area
--------------	-----------

ACRONYM

**lokare**

Code: **17057**

Set Attribute\_A: **comctn**; NOBJNM; OBJNAM; STATUS;

Set Attribute\_B: INFORM; NINFOM; NTXTDS; PICREP; SCAMIN; TXTDSC; **updmsg**

Set Attribute\_C: SORIND; SORDAT

Definition:

A lock area covers the entire area, in which the lock basins and any lock support are located.

References:

Remarks:

Distinction: Lock basin, lock basin part

Object Classes

**NEW GEO OBJECT CLASS**

Object class	Lock basin part
--------------	-----------------

ACRONYM

**lkbspt**

Code: **17058**

Set Attribute\_A: HORACC; **horcll**; **horclw**; HORLEN; HORWID; NOBJNM; OBJNAM;  
STATUS; TIMEND; TIMSTA

Set Attribute\_B: INFORM; NINFOM; NTXTDS; PICREP; SCAMIN; TXTDSC; **updmsg**

Set Attribute\_C: SORIND; SORDAT

Definition:

A lock basin is divided into several lock basin parts, if this lock basin has one ground level but several gates.

References:

Remarks:

Distinction: Lock area, Lock basin

Object Classes

**NEW GEO OBJECT CLASS**

Object class	Notice mark
--------------	-------------

ACRONYM

**notmrk**

Code: **17050**

Set Attribute\_A: **catnmk; fctnm; dirimp; disipd; disipu; disbk1; disbk2; addmrk; marsys; ORIENT; CONDTN; NOBJNM; OBJNAM; STATUS;**

Set Attribute\_B: **INFORM; NINFOM; NTXTDS; PICREP; SCAMIN; TXTDSC; updmmsg**

Set Attribute\_C: **SORIND; SORDAT**

Definition:

to be amended

References:

Remarks:

Distinction:





Object Classes

**NEW GEO OBJECT CLASS**

Object class	Refuse dump
--------------	-------------

ACRONYM

**refdmp**

Code: **17062**

Set Attribute\_A: **catrfd; comctn;** NOBJNM;OBJNAM, STATUS; TIMEND, TIMSTA,

Set Attribute\_B: INFORM; NINFOM; NTXTDS; PICREP; SCAMIN; TXTDSC; **updmsg**

Set Attribute\_C: SORIND; SORDAT

Definition:

At a refuse dump ships are able to unload their refuse like waste oil or black water.

References:

Remarks:

Object Classes

**NEW GEO OBJECT CLASS**

Object class	Route planning point
--------------	----------------------

ACRONYM

**rtplpt**

Code: **17063**

Set Attribute\_A: NOBJNM; OBJNAM;

Set Attribute\_B: INFORM; NINFOM; NTXTDS; PICREP; SCAMIN; TXTDSC; **updmsg**

Set Attribute\_C: SORIND; SORDAT

Definition:

A route planning point describes the projection of a feature object onto the waterway axis.

References:

Remarks:

Object Classes

**NEW GEO OBJECT CLASS**

Object class	Terminal
--------------	----------

ACRONYM

**termnl**

Code: **17064**

Set Attribute\_A:

**cattml; comctn; NOBJNM; OBJNAM; TIMEND; TIMSTA; trshgd, STATUS; unlocd**

Set Attribute\_B:

INFORM; NINFOM; NTXTDS; PICREP; SCAMIN; TXTDSC; **updmsg**

Set Attribute\_C:

SORIND; SORDAT

Definition:

A terminal covers that area on shore which provides buildings and constructions for the transfer of cargos from and to ships.

References:

Remarks:

Distinction: port area, harbour area, harbour basin, berths

Object Classes

**NEW GEO OBJECT CLASS**

Object class	Turning basin
--------------	---------------

ACRONYM

**trnbsn**

Code: **17065**

Set Attribute\_A:

HORCLR; NOBJNM; STATUS; OBJNAM

Set Attribute\_B:

INFORM; NINFOM; NTXTDS; PICREP; SCAMIN; TXTDSC; **updmmsg**

Set Attribute\_C:

SORIND; SORDAT

Definition:

An area of water or enlargement of a channel used for turning vessels (International Maritime Dictionary, 2d Edition)

References:

Remarks:





Attributes

**COPIED OBJECT ATTRIBUTES**

Attribute	Category of Anchorage area
-----------	----------------------------

ACRONYM

**catach**

Code: **17000**

Attribute type: L

Expected input:

ID	Meaning
1:	unrestricted anchorage
2:	deep water anchorage
3:	tanker anchorage
4:	explosives anchorage
5:	quarantine anchorage
6:	sea-plane anchorage
7:	small craft anchorage
8:	small craft mooring area
9:	anchorage for periods up to 24 hours
<b>10:</b>	<b>push tow anchorage</b>
<b>11:</b>	<b>anchorage for other vessels than push tows</b>
<b>12:</b>	<b>anchorage for other vessels than dangerous cargo vessels</b>

Definitions:

References:

Remarks:

Attributes

**COPIED OBJECT ATTRIBUTES**

Attribute	Category of bridge
-----------	--------------------

ACRONYM

**catbrg**

Code: **17006**

Attribute type: L

Expected input:

ID	Meaning
1:	fixed bridge ID 22
2:	opening bridge ID 23.1
3:	swing bridge ID 23.2
4:	lifting bridge ID 23.3
5:	bascule bridge ID 23.4
6:	pontoon bridge ID 23.5
7:	draw bridge ID 23.6
8:	transporter bridge ID 24
9:	footbridge
10:	viaduct
11:	aqueduct
12:	suspension bridge

Definitions:

References:

Remarks:



Attributes

**COPIED OBJECT ATTRIBUTES**

Attribute	Category of distance mark
-----------	---------------------------

ACRONYM

**catdis**

Code: **17001**

Attribute type: E

Expected input:

ID	Meaning	
1:	distance mark not physically installed	IF 40;
2:	visible mark, pole	IF 40;
3:	visible mark, board	IF 40;
4:	visible mark, unknown shape	IF 40;
5:	<b>kilometre mark, waterway bank</b>	
6:	<b>hectometre mark, waterway bank</b>	
7:	<b>kilometre mark, waterway axis</b>	
8:	<b>hectometre mark, waterway axis</b>	

Definitions:

References:

Remarks:

Attributes

**COPIED OBJECT ATTRIBUTES**

Attribute	Category of ferry
-----------	-------------------

ACRONYM

**catfry**

Code: **17007**

Attribute type: L

Expected input:

ID	Meaning	INT 1
1:	'free-moving' ferry	IM 50
2:	cable ferry	IM 51
3:	ice ferry	
4:	<b>swinging wire ferry</b>	

Definitions:

References:

Remarks:

The attribute `category of ferry` does not encode the various types of ferry vessel, but the manoeuvrability of the ferry. The value `cable ferry` indicates a ferry that follows a fixed route guided by a cable. A cable ferry may hinder the flow of other traffic.

Attributes

**COPIED OBJECT ATTRIBUTES**

Attribute	Category of harbour facilities
-----------	--------------------------------

ACRONYM

**cathaf**

Code: **17008**

Attribute type: L

Expected input:

ID	Meaning	
1-3:	deleted values (see new object class termnl)	
4-5	deleted values (see new object class hrbare)	
6	naval base	
7-8	deleted values (see new object class termnl)	
9:	ship yard	
10-11:	deleted values (see new object class termnl)	
<b>12:</b>	<b>harbour master's office</b>	<b>IF60</b>
<b>13:</b>	<b>pilot office</b>	
<b>14:</b>	<b>water-police office</b>	
<b>15:</b>	<b>customs office</b>	<b>IF61</b>
<b>16:</b>	<b>service and repair</b>	
<b>17:</b>	<b>quarantine station</b>	<b>IF62.1</b>

Definitions:

References:

Remarks:

Attributes

**COPIED OBJECT ATTRIBUTES**

Attribute	Category of signal station traffic
-----------	------------------------------------

ACRONYM

**catsit**

Code: **17002**

Attribute type: L

Expected input:

ID	Meaning	INT1
1:	port control	IT 23;
2:	port entry and departure	
3:	International Port Traffic	IT 21
4:	berthing	
5:	dock	
6:	lock	IT 24
7:	flood barrage	
8:	bridge passage	IT 25.1
9:	dredging	
<b>10:</b>	<b>oncoming traffic indication</b>	

Definitions:

References:

Remarks:

Attributes

**COPIED OBJECT ATTRIBUTES**

Attribute	Category of signal station warning
-----------	------------------------------------

ACRONYM

**catsiw**

Code: **17003**

Attribute type: L

Expected input:

ID	Meaning	INT1
1:	danger	IT 35
2:	maritime obstruction	
3:	cable	
4:	military practice	IT 36
5:	distress	IT 26
6:	weather	IT 29
7:	storm	IT 28
8:	ice	IT 30
9:	time	IT 31
10:	tide	IT 33
11:	tidal stream	IT 34
12:	tide gauge	IT 32.2
13:	tide scale	IT 32.1
14:	diving	
<b>15:</b>	<b>high water mark</b>	
<b>16:</b>	<b>vertical clearance indication</b>	
<b>17:</b>	<b>over/under vertical clearance indication</b>	
<b>18:</b>	<b>depth indication</b>	

Definitions:

References:

Remarks:

Attributes

**COPIED OBJECT ATTRIBUTES**

Attribute	Marks navigational – System of
-----------	--------------------------------

ACRONYM

**marsys**

Code: **17009**

Attribute type: E

Expected input:

ID	Meaning	INT1
1:	IALA A	IQ 130
2:	IALA B	IQ130
9:	no system	
10:	other system	
<b>11:</b>	<b>EU Inland waterway</b>	

Definition:

to be amended

Remarks:

Attributes

**COPIED OBJECT ATTRIBUTES**

Attribute	Restriction
-----------	-------------

ACRONYM

**restrn**

Code: **17004**

Attribute type: L

Expected input:

ID	Meaning	INT1
1:	anchoring prohibited	IN 20
2:	anchoring restricted	
3:	fishing prohibited	IN 21
4:	fishing restricted	
5:	trawling prohibited	
6:	trawling restricted	
7:	entry prohibited	IN 2.2
8:	entry restricted	
9:	dredging prohibited	
10:	dredging restricted	
11:	diving prohibited	
12:	diving restricted	
13:	no wake	
14:	area to be avoided	IM 29.1
15:	construction prohibited	
16:	<b>overtaking prohibited</b>	
17:	<b>passing prohibited</b>	
18:	<b>standstill prohibited</b>	
19:	<b>standstill restricted</b>	
20:	<b>berthing prohibited</b>	
21:	<b>berthing restricted</b>	
22:	<b>turning prohibited</b>	
23:	empty	
24:	<b>speed limited</b>	
25:	<b>restricted fairway depth</b>	
26:	<b>restricted fairway width</b>	

Definitions:

References:

Remarks:

Attributes

**COPIED OBJECT ATTRIBUTES**

Attribute	Vertical datum
-----------	----------------

ACRONYM

**verdat**

Code: **17005**

Attribute type: E

Expected input:

ID : Meaning

...

- 30. Equivalent height of water (German GIW)
- 31. Highest Shipping Height of Water (German HSW)
- 32. Amsterdam Ordinance Datum (NAP)
- 33. current waterlevel
- 34. RNW for the German Danube
- 35. RNW for the Danube Commission
- 36. HSW (Highest Shipping Height of Water) for the Danube
- 37. Heigth above the Adriatic sea

Definition:

to be amended

References:

to be amended

Remarks:



Attributes

**NEW OBJECT ATTRIBUTES**

Attribute	Additional mark
-----------	-----------------

ACRONYM

**addmrk**

Code: **17050**

Attribute type: L

Expected input:

ID:	Meaning
<b>1:</b>	<b>top (board)</b>
<b>2:</b>	<b>bottom (board)</b>
<b>3:</b>	<b>right (triangle to the right)</b>
<b>4:</b>	<b>left (triangle to the left)</b>

Definition:

The kind and location of an additional mark at a notice mark

References:

Remarks:

Distinction: notmrk

Attributes

**NEW OBJECT ATTRIBUTES**

Attribute	Bunker vessel, availability
-----------	-----------------------------

ACRONYM

**bunves**

Code: **17065**

Attribute type: E

Expected input:

ID: Meaning

- 1: **bunker vessel available**
- 2: **no bunker vessel available**

Definition:

The availability of a bunker vessel at a bunker station

References:

Remarks:

Attributes

**NEW OBJECT ATTRIBUTES**

Attribute	Category of bank
-----------	------------------

ACRONYM

**catbnk**

Code: **17051**

Attribute type: E

Expected input:

ID:	Meaning
<b>1:</b>	<b>steep bank</b>
<b>2:</b>	<b>flat bank</b>
<b>3:</b>	<b>embankment, fastened</b>
<b>4:</b>	<b>embankment, unfastened</b>

Definition:

References:

Remarks:

Attributes

**NEW OBJECT ATTRIBUTES**

Attribute	Category of berth
-----------	-------------------

ACRONYM

**catbrt**

Code: **17066**

Attribute type: L

Expected input:

ID:	Meaning
1.	<b>loading</b>
2.	<b>unloading</b>
3.	<b>overnight accommodation</b>
4.	<b>push tow berths</b>
5.	<b>berths for other vessels than push tows</b>
6.	<b>berths for other vessels than dangerous cargo vessels</b>

Definition:

References:

Remarks:

Distinction: transshipment goods

Attributes

**NEW OBJECT ATTRIBUTES**

Attribute	Category of bunker station
-----------	----------------------------

ACRONYM

**catbun**

Code: **17067**

Attribute type: L

Expected input:

ID	Meaning
<b>1:</b>	<b>diesel oil</b>
<b>2:</b>	<b>water</b>
<b>3:</b>	<b>ballast</b>

Definitions:

References:

Remarks:

Attributes

**NEW OBJECT ATTRIBUTES**

Attribute	Category of CEMT class
-----------	------------------------

ACRONYM

**catccl**

Code: **17068**

Attribute type: L

Expected input:

ID	Meaning
<b>1:</b>	<b>0 small vessels and pleasure craft</b>
<b>2:</b>	<b>I peniche</b>
<b>3:</b>	<b>II campine barge</b>
<b>4:</b>	<b>III Dortmund-Ems barge</b>
<b>5:</b>	<b>IV Rhine-Herne barge</b>
<b>6:</b>	<b>Va Large Rhine barge; 1-barge push-tow unit</b>
<b>7:</b>	<b>Vb 2-barge push-tow unit; long formation</b>
<b>8:</b>	<b>Vla 2-barge push-tow unit; wide formation</b>
<b>9:</b>	<b>Vlb 4-barge push-tow unit</b>
<b>10:</b>	<b>Vlc 6-barge push-tow unit</b>
<b>11:</b>	<b>No CEMT class</b>

Definitions:

References:

Remarks:

Attributes

**NEW OBJECT ATTRIBUTES**

Attribute	Category of communication
-----------	---------------------------

ACRONYM

**catcom**

Code: **17069**

Attribute type: L

Expected input:

ID	Meaning
<b>1:</b>	<b>VTS centre</b>
<b>2:</b>	<b>VTS sector</b>
<b>3:</b>	<b>IVS point</b>
<b>4:</b>	<b>MID</b>
<b>5:</b>	<b>lock</b>
<b>6:</b>	<b>bridge</b>
<b>7:</b>	<b>custom</b>
<b>8:</b>	<b>harbour</b>

Definitions:

References:

Remarks:

Attributes

**NEW OBJECT ATTRIBUTES**

Attribute	Category of harbour area
-----------	--------------------------

ACRONYM

**cathbr**

Code: **17070**

Attribute type: L

Expected input:

ID	Meaning
<b>1:</b>	<b>custom harbour</b>
<b>2:</b>	<b>port of refuge</b>
<b>3:</b>	<b>yacht harbour/marina</b>
<b>4:</b>	<b>fishing harbour</b>
<b>5:</b>	<b>private harbour</b>

Definitions:

References:

Remarks:



Attributes

**NEW OBJECT ATTRIBUTES**

Attribute	Category of notice mark
-----------	-------------------------

ACRONYM

**catnmk**

Code: **17052**

Attribute type: E

Expected input:

ID	Meaning
1:	<b>entry prohibited, (A.1)</b>
2:	<b>closed area, but small craft boats without engine permitted (A.1a, only RheinSchPV and Binnenvaatpolitiereglement)</b>
3:	<b>overtaking prohibited, (A.2)</b>
4:	<b>overtaking between push tows and towing units prohibited, (A.3)</b>
5:	<b>no passing and overtaking, (A.4)</b>
6:	<b>berthing prohibited, (A.5)</b>
7:	<b>berthing, with distance from the bank, (A.5.1)</b>
8:	<b>anchoring prohibited, (A.6)</b>
9:	<b>making fast to the bank prohibited, (A.7)</b>
10:	<b>turning prohibited, (A.8)</b>
11:	<b>avoid wave wash, (A.9)</b>
12:	<b>passing on left side prohibited, (A.10)</b>
13:	<b>passing on right side prohibited, (A.10)</b>
14:	<b>boats with engine prohibited, (A.12)</b>
15:	<b>sport and pleasure boats prohibited, (A.13)</b>
16:	<b>waterskiing prohibited, (A.14)</b>
17:	<b>sailing boats prohibited, (A.15)</b>
18:	<b>boats without engines or sails prohibited, (A.16)</b>
19:	<b>windsurfing prohibited, (A.17)</b>
20:	<b>waterscooters and jetskis prohibited, (A.20)</b>
21:	<b>highspeed motorboats prohibited (A.18)</b>
22:	<b>slipping of boats prohibited, (A.19)</b>
23:	<b>mandatory traffic direction, left, (B.1)</b>
24:	<b>mandatory traffic direction, right, (B.1)</b>
25:	<b>mandatory change of the fairwayside to port, (B.2a)</b>
26:	<b>mandatory change of the fairwayside to starboard, (B.2b)</b>
27:	<b>port fairwayside is mandatory traffic direction, (B.3a)</b>
28:	<b>starboard fairwayside is mandatory traffic direction, (B.3b)</b>
29:	<b>mandatory crossing of the fairwayside to port, (B.4a)</b>
30:	<b>mandatory crossing of the fairwayside to starboard, (B.4b)</b>
31:	<b>mandatory stop, (B.5)</b>
32:	<b>maximum speed limit, (B.6)</b>
33:	<b>mandatory sound signal, (B.7)</b>
34:	<b>special attention, (B.8)</b>
35:	<b>give way to other vessels when entering the main fairway, (B.9a)</b>
36:	<b>give way to other vessels when crossing the main fairway, (B.9b)</b>
37:	<b>mandatory radiophone, (B.11)</b>

- 38: restricted fairway depth, (C.1)
- 39: restricted vertical clearance, (C.2)
- 40: restricted width of the fairway or passage, (C.3)
- 41: general restrictions (with additional sign), (C.4)
- 42: restricted width of the waterway at the left bank, (C.5)
- 43: restricted width of the waterway at the right bank, (C.5)
- 44: recommended passage for both directions, (D.1a)
- 45: recommended passage for only one direction, (D.1b)
- 46: recommended passage on right side, (D.2)
- 47: recommended passage on left side, (D.2)
- 48: recommended traffic direction, left; (D.3)
- 49: recommended traffic direction, right, (D.3)
- 50: entry permitted, (E.1)
- 51: overhead power line crossing, (E.2)
- 52: weir, (E.3)
- 53: cable ferry, (E.4)
- 54: ferry, (E.4b)
- 55: berthing permitted, (E.5)
- 56: berthing permitted, with distance, (E.5.1)
- 57: berthing permitted, between two distances, (E.5.2)
- 58: maximum number of vessels laying side by side, (E.5.3)
- 59: berthing facilities for push tows, (E.5.4)
- 60: berthing facilities for push tows with one blue cone, (E.5.5)
- 61: berthing facilities for push tows with two blue cones, (E.5.6)
- 62: berthing facilities for push tows with three blue cones, (E.5.7)
- 63: berthing facilities for other vessels than push tows, (E.8)
- 64: berthing facilities for other vessels than push tows with one blue cone, (E.5.9)
- 65: berthing facilities for other vessels than push tows with two blue cones, (E.5.10)
- 66: berthing facilities for other vessels than push tows with three blue cones, (E.5.11)
- 67: berthing facilities for all vessels (E.5.12)
- 68: berthing facilities for all vessels with one blue cone, (E.5.13)
- 69: berthing facilities for all vessels with two blue cones, (E.5.14)
- 70: berthing facilities for all vessels with three blue cones, (E.5.15)
- 71: anchoring permitted, (E.6)
- 72: making fast to the bank permitted, (E.7)
- 73: facilities for transfer of vehicles, (E.7.1.)
- 74: turning permitted, (E.8)
- 75: crossing with secondary waterway ahead, (E.9a)
- 76: secondary waterway ahead on the right, (E.9b)
- 77: secondary waterway ahead on the left, (E.9c)
- 78: secondary waterway ahead (main waterway right), (E.9d)
- 79: secondary waterway ahead (main waterway left), (E.9e)
- 80: secondary waterway left (main waterway right), (E.9f)
- 81: secondary waterway right (main waterway left) (E.9g)
- 82: secondary waterway ahead and left (main waterway right), (E.9h)
- 83: secondary waterway ahead and right (main waterway left), (E.9i)
- 84: crossing with main waterway ahead, (E.10a)
- 85: junction with main waterway ahead, (E.10b)
- 86: junction with main waterway ahead and right, (E.10.c)
- 87: junction with main waterway ahead and left, (E.10d)
- 88: junction with main waterway ahead and right (secondary waterway left), (E.10e)
- 89: junction with main waterway ahead and left (secondary waterway right), (E.10f)

- 90: **end of prohibition or regulation, (E.11)**
- 91: **drink water (E.13)**
- 92: **telephone (E.14)**
- 93: **boats with engine permitted (E.15)**
- 94: **sport and pleasure boats permitted, (E.16)**
- 95: **waterski area, (E.17)**
- 96: **sailing boats permitted, (E.18)**
- 97: **boats without engine or sails permitted, (E.19)**
- 98: **windsurfing permitted, (E.20)**
- 99: **nautical radio information, (E.23)**
- 100: **waterscooters, jetskis permitted, (E.24)**
- 101: **high speed motorboats permitted, (E.21)**
- 102: **slipping of boats permitted, (E.22)**

Definition:

References: All order numbers are referenced to CEVNI (European Code for Inland Waterways) revision 2, edited by the Economic Commission for Europe of the United Nations, 2001.

Remarks:

Attributes

**NEW OBJECT ATTRIBUTES**

Attribute	Category of refuse dump
-----------	-------------------------

ACRONYM

**catrfd**

Code: **17071**

Attribute type: L

Expected input:

ID	Meaning
<b>1:</b>	<b>cargo residue/slop</b>
<b>2:</b>	<b>waste oil</b>
<b>3:</b>	<b>gray/black water</b>
<b>4:</b>	<b>domestic refuse</b>

Definitions:

References:

Remarks:

Attributes

**NEW OBJECT ATTRIBUTES**

Attribute	Category of terminal
-----------	----------------------

ACRONYM

**cattml**

Code: **17072**

Attribute type: L

Expected input:

ID	Meaning	INT1
<b>1:</b>	<b>Passenger terminal</b>	
<b>2:</b>	<b>Ferry terminal</b>	<b>IF10</b>
<b>3:</b>	<b>Transshipment terminal</b>	
<b>4:</b>	<b>RoRo terminal</b>	

Definitions:

A terminal provides facilities for handling particular forms of cargo (IHO Dictionary, S-32, 5th Edition, 5343).

References:

Remarks:

Distinction: transshipment goods

Attributes

**NEW OBJECT ATTRIBUTES**

Attribute	Category of waterway mark (buoy, beacon)
-----------	--

ACRONYM

**catwwm**

Code: **17112**

Attribute type: E

Expected input:

ID	:	Meaning
1:		<b>right side</b>
2:		<b>left side</b>
3:		<b>separation</b>
4:		<b>right fairway side</b>
5:		<b>left fairway side</b>
6:		<b>fairway separation</b>
7:		<b>fairway at the right side</b>
8:		<b>fairway at the left side</b>
9:		<b>fairway change to the right side</b>
10:		<b>fairway change to the left side</b>
11:		<b>obstruction at the right side</b>
12:		<b>obstruction at the left side</b>
13:		<b>turn off at the right side</b>
14:		<b>turn off at the left side</b>
15:		<b>junction at the right side</b>
16:		<b>junction at the left side</b>
17:		<b>harbour entry at the right side</b>
18:		<b>harbour entry at the left side</b>
19:		<b>bridge mark</b>

Definition:

References:

This list is referenced to the German Rheinschiffahrts-Polizeiverordnung (RheinSchPV) and Wasserstraßen-Verkehrsordnung (WVO) of Republic of Austria.

Remarks:

Attributes

**NEW OBJECT ATTRIBUTES**

Attribute	Class of dangerous cargo
-----------	--------------------------

ACRONYM

**clsdng**

Code: **17055**

Attribute type: E

Expected input:

ID	:	Meaning
<b>1</b>	:	<b>one blue light/cone</b>
<b>2</b>	:	<b>two blue lights/cones</b>
<b>3</b>	:	<b>three blue lights/cones</b>
<b>4</b>	:	<b>no blue lights/cones</b>

Definition:

References:

Remarks:

Attributes

**NEW OBJECT ATTRIBUTES**

Attribute	Communication
-----------	---------------

ACRONYM

**comctn**

Code: **17073**

Attribute type: S

Expected input:

all kinds of communication, e.g. phone or fax number, email, address etc.

Definition:

References:

Remarks:



Attributes

**NEW OBJECT ATTRIBUTES**

Attribute	Direction of impact
-----------	---------------------

ACRONYM

**dirimp**

Code: **17056**

Attribute type: L

Expected input:

ID	:	Meaning
1	:	<b>upstream</b>
2	:	<b>downstream</b>
3	:	<b>to the left bank</b>
4	:	<b>to the right bank</b>

Definition:

Direction of the impact of an area, which is signed by notice marks.

References:

Remarks:

Attributes

**NEW OBJECT ATTRIBUTES**

Attribute	Distance from bank, first
-----------	---------------------------

ACRONYM

**disbk1**

Code: **17057**

Attribute type: F

Definition:

Minimum distance of the impact of an area, which is signed by notice marks. The distance is measured from the notice mark rectangular to the bank.

References:

Minimum value: 0

Indication:

Unit: defined in the HUNI subfield of the DSPM record or in the HUNITS attribute of the M\_UNIT meta object class, e.g. metre (m)

Resolution: 1 metre

Format:

xx

Example:

30

Remarks:

Attributes

**NEW OBJECT ATTRIBUTES**

Attribute	Distance from bank, second
-----------	----------------------------

ACRONYM

**disbk2**

Code: **17058**

Attribute type: F

Definition:

Maximum distance of the impact of an area, which is signed by notice marks. The distance is measured from the notice mark rectangular to the bank.

References:

Minimum value: 0

Indication:

Unit: defined in the HUNI subfield of the DSPM record or in the HUNITS attribute of the M\_UNIT meta object class, e.g. metre (m)  
Resolution: 1 metre

Format:

xx

Example:

50

Remarks:

Attributes

**NEW OBJECT ATTRIBUTES**

Attribute	Distance of impact, upstream
-----------	------------------------------

ACRONYM

**disipu**

Code: **17059**

Attribute type: F

Definition:

Upstream distance of the impact of an area, which is signed by notice marks. The distance is normally given on an additional mark left and/or right of the notice mark.

References:

Minimum value: 0

Indication:

Unit: defined in the HUNI subfield of the DSPM record or in the HUNITS attribute of the M\_UNIT meta object class, e.g. metre (m)

Resolution: 1 metre

Format:

xxx

Example:

100

Remarks:

Attributes

**NEW OBJECT ATTRIBUTES**

Attribute	Distance of impact, downstream
-----------	--------------------------------

ACRONYM

**disipd**

Code: **17060**

Attribute type: F

Definition:

Downstream distance of the impact of an area, which is signed by notice marks. The distance is normally given on an additional mark left and/or right of the notice mark.

References:

Minimum value: 0

Indication:

Unit: defined in the HUNI subfield of the DSPM record or in the HUNITS attribute of the M\_UNIT meta object class, e.g. metre (m)

Resolution: 1 metre

Format:

xxx

Example:

100

Remarks:

Attributes

**NEW OBJECT ATTRIBUTES**

Attribute	Elevation 1
-----------	-------------

ACRONYM

**eleva1**

Code: **17061**

Attribute type: F

Definition:

Elevation 1 of a depth area

References:

Minimum value: **0.00**

Indication:

Unit: defined in the HUNI subfield of the DSPM record or in the HUNITS attribute of the M\_UNIT meta object class, e.g. metre (m)

Resolution: 0.01 metre

Format:

xxx.xx

Example:

12.34

Remarks:

Attributes

**NEW OBJECT ATTRIBUTES**

Attribute	Elevation 2
-----------	-------------

ACRONYM

**eleva2**

Code: **17062**

Attribute type: F

Definition:

Elevation 2 of a depth area

References:

Minimum value: **0.00**

Indication:

Unit: defined in the HUNI subfield of the DSPM record or in the HUNITS attribute of the M\_UNIT meta object class, e.g. metre (m)

Resolution: 0.01 metre

Format:

xxx.xx

Example:

12.34

Remarks:

Attributes

**NEW OBJECT ATTRIBUTES**

Attribute	Function of notice mark
-----------	-------------------------

ACRONYM

**fnctnm**

Code: **17063**

Attribute type: E

Expected input:

ID	:	Meaning
1	:	<b>prohibition mark</b>
2	:	<b>regulation mark</b>
3	:	<b>restriction mark</b>
4	:	<b>recommendation mark</b>
5	:	<b>information mark</b>

Definition:

References:

Remarks:



Attributes

**NEW OBJECT ATTRIBUTES**

Attribute	Horizontal clearance, length
-----------	------------------------------

ACRONYM

**horcli**

Code: **17074**

Attribute type: F

Definition:

The length of an object, such as a lock or basin, which is available for safe navigation. This may, or may not, be the same as the total physical length (HORLEN) of the object

References:

Minimum value: 0

Indication:

Unit: defined in the HUNI subfield of the DSPM record or in the HUNITS attribute of the M\_UNIT meta object class, e.g. metre (m)  
Resolution: 0.1 metres

Format:

xxx.x

Example:

125.1 for a width of 125.1 metres.

Remarks:

Distinction: HORLEN

Attributes

**NEW OBJECT ATTRIBUTES**

Attribute	Horizontal clearance, width
-----------	-----------------------------

ACRONYM

**horclw**

Code: **17075**

Attribute type: F

Definition:

The width of an object, such as a lock or basin, which is available for safe navigation. This may, or may not, be the same as the total physical width (HORWID) of the object.

References:

Minimum value: 0

Indication:

Unit: defined in the HUNI subfield of the DSPM record or in the HUNITS attribute of the M\_UNIT meta object class, e.g. metre (m)  
Resolution: 0.1 metres

Format:

xxx.x

Example:

125.1 for a width of 125.1 metres.

Remarks:

Distinction: HORWID

Attributes

**NEW OBJECT ATTRIBUTES**

Attribute	Transshipping goods
-----------	---------------------

ACRONYM

**trshgd**

Code: **17076**

Attribute type: L

Expected input:

ID:	Meaning
<b>1:</b>	<b>containers</b>
<b>2:</b>	<b>bulk goods</b>
<b>3:</b>	<b>oil</b>
<b>4:</b>	<b>fuel</b>
<b>5:</b>	<b>chemicals</b>
<b>6:</b>	<b>liquid goods</b>
<b>7:</b>	<b>explosive goods</b>
<b>8:</b>	<b>fish</b>
<b>9:</b>	<b>cars</b>
<b>10:</b>	<b>general cargo</b>

Definition:

The kind of goods which are transferred from and to ships

References:

Remarks:

Attributes

**NEW OBJECT ATTRIBUTES**

Attribute	UN Location Code
-----------	------------------

ACRONYM

**unlocd**

Code: **17077**

Attribute type: S

Definition:

For locations the UN CEFACT Recommendation 16 (UN LOCODE - unique identification of locations and harbours) is proposed for use wherever possible for places and harbours.

For terminals 5 digits are added to identify the terminals within a harbour.

References:

The UN locodes can be obtained from the Internet ([www.unece.org/locode](http://www.unece.org/locode)).  
The terminal codes are available at Bureau Telematica in the Netherlands

Indication:

Format:

UN LOCODE: Alphanumeric, 5 digits

Terminal code: Alphanumeric, 5 digits, always in combination with UN-LOCODE

Example:

UN LOCODE of Bingen:

DEBIN

UN LOCODE and terminal code of ECT Duisburg:

DEDUIECTDU

Remarks:

Attributes

**NEW OBJECT ATTRIBUTES**

Attribute	Update message
-----------	----------------

ACRONYM

**updmsg**

Code: **40000**

Attribute type: S

Expected input:

Definitions:

Textual update information about an object

References:

Remarks:

The attribute `update message` can be used to inform the mariner about the reason for an update or special warnings referring to the object.

Attributes

**OBJECT ATTRIBUTES**

Attribute	National update message
-----------	-------------------------

ACRONYM

**nupdms**

Code: **40020**

Attribute type: S

Expected input:

Definitions:

Textual update information about an object in national language

References:

Remarks:

The attribute `update message` can be used to inform the mariner about the reason for an update or special warnings referring to the object.

Attributes

**NEW OBJECT ATTRIBUTES**

Attribute	Waterway distance
-----------	-------------------

ACRONYM

**wtdis**

Code: **17064**

Attribute type: F

Definition:

The distance measured from an origin of a river or canal.

References:

Minimum value: 0

Indication:

Unit: kilometres  
Resolution: 0.1

Format:

xxx.x

Example:

523.4 for a waterway distance of 523.4 km.

Remarks:

## 7 Overview of Inland ECDIS Object Classes and Attributes

Object class description	Acronym	Code	Page
Anchor berth	achbrt	17000	22
Anchorage area	achare	17001	23
Berth	berths	17010	24
Bridge	bridge	17011	25
Cable overhead	cblohd	17012	26
Canal bank	canbnk	17002	27
Depth area	depare	17003	28
Distance mark	dismar	17004	29
Ferry route	feryrt	17013	30
Harbour Area	hrbare	17014	31
Harbour Facilities	hrbfac	17015	32
Lock Basin	lokbsn	17016	33
Radio calling-in point	rdocal	17017	34
Restricted area	resare	17005	35
River bank	rivbnk	17006	36
Signal station traffic	sistat	17007	37
Signal station warning	sistaw	17008	38
Top Mark	topmar	17009	39
Navigational system of marks	m_nsys	17018	40
Beacon water-way	bcnwtw	17060	41
Bridge area	brgare	17053	42
Bunker station	bunsta	17054	43
Buoy water-way	boywtw	17061	44
Communication Area	comare	17055	45
Harbour Basin	hrbbsn	17056	46
Lock area	lokare	17057	47
Lock basin part	lkbspt	17058	48
Notice mark	notmrk	17050	49
Port Area	prtare	17059	50
Refuse dump	refdmp	17062	51
Route planning point	rtplpt	17063	52
Terminal	termnl	17064	53
Turning basin	trnbsn	17065	54
Waterway axis	wtwaxs	17051	55
Waterway profile	wtwprf	17052	56
<b>Attribute description</b>			
Category of Anchorage area	catach	17000	57
Category of bridge	catbrg	17006	58
Category of distance mark	catdis	17001	59
Category of ferry	catfry	17007	60
Category of harbour facilities	cathaf	17008	61
Category of signal station traffic	catsit	17002	62
Category of signal station warning	catsiw	17003	63
Marks navigational – System of	marsys	17009	64
Restriction	restrn	17004	65
Vertical datum	verdat	17005	66



Additional mark	addmrk	17050	67
Bunker vessel	bunves	17065	68
Category of bank	catbnk	17051	69
Category of berth	catbrt	17066	70
Category of bunker	catbun	17067	71
Category of CEMT class	catccl	17068	72
Category of communication	catcom	17069	73
Category of harbour area	cathbr	17070	74
Category of notice mark	catnmk	17052	75
Category of refuse dump	catrfd	17071	78
Category of terminal	cattml	17072	79
Category of waterway mark	catwwm	17112	80
Class of dangerous cargo	clsdng	17055	81
Communication	comctn	17073	82
Direction of impact	dirimp	17056	83
Distance from bank	disbk1	17057	84
Distance from bank	disbk2	17058	85
Distance of impact, upstream	disipu	17059	86
Distance of impact, downstream	disipd	17060	87
Elevation 1	eleva1	17061	88
Elevation 2	eleva2	17062	89
Function of notice mark	fnctnm	17063	90
Horizontal clearance, length	horcll	17074	91
Horizontal clearance, width	horclw	17075	92
Transshipping goods	trshgd	17076	93
UN Location Code	unlocd	17077	94
Update message	updmsg	40000	95
National update message	nupdms	40020	96
Waterway distance	wtwdis	17064	97

## 8 List of additional used S-57 Object Attributes

-A-

-B-

-C-

COLOUR	Colour
COMCHA	Communication channel
CONDTN	Condition
CONRAD	Conspicuous, radar
CONVIS	Conspicuous, visually

-D-

DATEND	Date end
DATSTA	Date start

-E-

EXPSOU	Exposition of sounding
--------	------------------------

-F-

-G-

-H-

HORACC	Horizontal accuracy
HORCLR	Horizontal clearance
HORLEN	Horizontal length
HORWID	Horizontal width

-I-

INFORM	Information
--------	-------------

-J-

-K-

-L-

-M-

-N-

NATCON	Nature of construction
--------	------------------------

-O-

OBJNAM	Object name
ORIENT	Orientation

-P-

PEREND	Periodic date end
PERSTA	Periodic date start
PICREP	Pictorial representation

-Q-

QUASOU	Quality of sounding measurement
--------	---------------------------------

-R-

RECDAT	Recording date
RECIND	Recording indication

-S-	
SCAMIN	Scale minimum
SOUACC	Sounding accuracy
SORDAT	Source date
SORIND	Source indication
STATUS	Status
-T-	
TXTDSC	Textual description
TIMEND	Time end
TIMSTA	Time start
TRAFIC	Traffic flow
-U-	
-V-	
VERACC	Vertical accuracy
VERCLR	Vertical clearance
VERCCL	Vertical clearance, closed
VERCOP	Vertical clearance, opened
VERCSA	Vertical clearance, safe
VERLEN	Vertical length
	Additional National Language Attributes
NINFOM	Information in national language
NOBJNM	Object name in national language
NTXTDS	Textual description in national language

Page 102 intentionally left free

Edition 1.02  
16.10.2003

## **Standard**

# **Electronic Chart Display and Information System for Inland Waterways**

## **Inland ECDIS**

---

---

### **SECTION 2**

---

---

## **Inland ECDIS Data Standard**

## **Annex A of Appendix A**

# **Codes for Producers and Waterways**

In addition to

IHO –S-57 IHO Codes

### Codes for IHO Members (extract from IOH-S-57, Appendix A, Annex A)

County Name	Country Code	Producer Name	Producer Code	
Belgium	BE	Antwerpse Zeediensten Hydrografie 1)	30	BE
Germany	DE	Bundesamt fuer Seeschifffahrt und Hydrographie 1)	180	DE
France	FR	Service Hydrographique et Océanographique de la Marine 1)	170	FR
Netherlands	NL	Dienst der Hydrografie Koninklijke Marine	310	NL

1) only for maritime purposes

### Codes for Non-IHO Members

Country Name	Country Code	Producer Name	Producer Code	
Netherlands	NL	Rijkswaterstaat	7979	1R
Austria	A	Austrian Supreme Shipping Authority	12096	2W
Germany	DE	Wasser- und Schifffahrtsverwaltung des Bundes	7984	1W
Switzerland	CH	Bundesamt für Wasser und Geologie		

### Codes for Waterways

Waterway Name	Waterway Code	Remark
Danube	D0	Km 0 – 1000 (with Sulina branch)
Danube	D1	Km 1000 – 2000
Danube	D2	Km 2000 -Source
Danube	D3	Chilia branch
Danube	D4	Cernavoda canal
Neckar	NE	
Main	MA	
Mosel	MO	
Elbe	EL	
Rhine	RH	
Nederrijn / Lek	RL	
Waal	WA	

If a private company decides to produce ENC's, it shall register a producer code with the "Open ECDIS Forum" at [www.openecd.org](http://www.openecd.org).

Edition 1.02  
16.10.2003

## **Standard**

# **Electronic Chart Display and Information System for Inland Navigation**

## **Inland ECDIS**

---

---

### **SECTION 2**

---

---

## **Data Standard for Inland ECDIS**

## **Appendix B**

# **Product Specification for Inland ECDIS**

in addition to the

IHO-S-57 ENC Product Specification

## Contents

1	General.....	107
2	Additions to the ENC Product Specification of IHO.....	107
to 2.1	Navigational purpose (usage) .....	107
to 2.2	Cells.....	107
to 3.3	Objects permitted for use in ENC and their geometric primitives.....	107
to 3.4	Meta objects .....	108
to 3.5.2	Mandatory attributes .....	108
to 3.7	Time varying objects.....	108
to 3.10	Depth area .....	108
to 4.1	Horizontal datum .....	108
to 5.6.3	Data set files.....	110
to 6.3.2.1	Data set identification field.....	110



## 1 General

This Product Specification for Inland ECDIS is a set of specifications intended to enable ENC manufacturers to produce consistent Inland ENC, and to use data efficiently in an ECDIS application that satisfies the Performance Standards for Inland ECDIS (Section 1 of this Standard for Inland ECDIS). An Inland ENC shall be produced in accordance with the regulations defined in these documents:

- this Product Specification for Inland ECDIS
- Annex A "Use of the Object Catalogue for Inland ECDIS"
- Appendix B.1 to the Standard IHO-S-57 ("ENC Product Specification")
- the documents, that are listed as references in Section 1 of this Standard for Inland ECDIS in clause 2.

2

Definitions of the used terms may be found in Section 5 ("Glossary of Terms") of this standard.

The numbering correlates to S-57 Appendix B.1.

## 2 Additions and Clarifications to the "ENC Product Specification" of the IHO

### Further to 2.1 Navigational purpose (usage)

Nr.	Navigational purpose (usage)	Intended use
1 S57	Overview	For route planning and oceanic crossing.
2 S57	General	For navigating oceans, approaching coasts and route planning.
3 S57	Coastal	For navigating along the coastline, either inshore or offshore.
4 S57	Approach	Navigating the approaches to ports or mayor channels or through intricate or congested waters.
5 S57	Harbour	Navigating within ports, harbours, bays, rivers and canals, for anchorages.
6 S57	Berthing	Detailed data to aid berthing.
<b>7 new</b>	<b>River</b>	<b><i>Navigating the inland waterways (skin cell).</i></b>
<b>8 new</b>	<b>River harbour</b>	<b><i>Navigating within ports and harbours on inland waterways (skin cell).</i></b>
<b>9 new</b>	<b>River berthing</b>	<b><i>Detailed data to aid berthing manoeuvring in inland navigation (skin cell).</i></b>
<b>L new</b>	<b>Overlay</b>	<b><i>Overlay cell to be displayed in conjunction with skin cells</i></b>

The navigational purposes 1 to 8 and 9 may be used by authorities as well as private bodies. Navigational purpose 9 should be used by private bodies only.

It is allowed to assign a range of usages to overlay cells (see "to 5.6.3).

### Further to 2.2 Cells

In Inland ENC, skin-off-the-earth objects (group 1) within two overlapping cells with the same navigational purpose must not overlap. Objects of overlay cells (always group 2) are allowed to overlap other objects in other cells.

The minimum size of coverage at both sides of the waterway should be outside the radar coverage.

### Further to 3.3 Objects permitted for use in ENC and their geometric primitives

The following object classes were copied for use in Inland ENC.

<b>achare</b>	P	A			<b>achbrt</b>	P	A			<b>berths</b>	P	L	A		<b>bridge</b>	P	L	A	
<b>cblohd</b>		L			<b>canbnk</b>		L			<b>depare</b>			A		<b>dismar</b>	P			
<b>feryrt</b>		L	A		<b>hrbare</b>			A		<b>hrbfac</b>	P		A		<b>lokbsn</b>			A	
<b>m_nsys</b>			A		<b>rdocal</b>	P	L			<b>resare</b>			A		<b>rivbnk</b>		L		
<b>sistat</b>	P				<b>sistaw</b>	P				<b>topmar</b>	P								

Table 3.1

P = point, L = line, A= area

The official object classes **CANBNK** and **RIVBNK** are existing in S-57 but their application is not permitted any more.

The copied object class **depare** may only be applied if it shall be updated to the current waterlevel.

The following object classes were added for use in Inland ENC.

<b>bcnwtw</b>	P				<b>brgare</b>			A		<b>boywtw</b>	P				<b>bunsta</b>	P			
<b>comare</b>			A		<b>hrbbsn</b>			A		<b>locare</b>			A		<b>lkbspt</b>			A	
<b>notmrk</b>	P				<b>prtare</b>			A		<b>refdmp</b>	P				<b>rtplpt</b>	P			
<b>termnl</b>	P		A		<b>trnbsn</b>	P		A		<b>wtwaxs</b>		L			<b>wtwprf</b>		L		

The application of the waterway axis object class **wtwaxs** (waterway axis) with the object **dismar** (distance mark) is mandatory.

### Further to 3.4 Meta objects

The meta object **m\_nsys** with the attribute **marsys** (to indicate the system of navigational marks) must provide an exhaustive non-overlapping coverage of the part of the cell containing data.

### Further to 3.5.2 Mandatory attributes

The following attributes are mandatory for object classes, which were

- added for use in Inland ENC (new) or

- which already exist and have been extended for use in Inland ECDIS (copied):

Object class	Attribute					
bcnwtw	catwwm	BCNSPH	COLOUR			
bcnwtw	catwwm	BOYSHP	COLOUR			
bridge	if fixed if not fixed	VERCLR VERCCL	VERCOP			
cblohd	VERSCA	or if this is unknown	VERCLR			
depare	DRVAL1	DRVAL2				
dismar	if located on axis	INFORM				
feryrt	catfry					
hrbfac	cathaf					
lkbspt	horcll	horclw				
lokbsn	horcll	horclw				
rdocal	dirimp					
sistat	catsit					
sistaw	catsiw					
notmrk	fnctnm	catnmk	dirimp			ORIENT <sup>1)</sup>
topmar	marsys	TOPSHP				
wtwaxs	OBJNAM					

<sup>1)</sup> if fixed at a bridge

### Further to 3.7 Time varying objects

The Inland ENC may contain time independent depth information as "minimum required depth" (Solltiefe in German) related to a reference waterlevel (on the Rhine river the "Equivalent Water Level" GIW).

Besides that Inland ECDIS may also contain time-variable depth information related to the actual water level at reference gauges. The rules for this will be formulated in an update of this standard when sufficient experience is gained.

### To 3.10.1 Depth area

Depth area (depare) is part of group one (skin of the earth)

### Further to 4.1 Horizontal datum

The horizontal datum of an Inland ENC shall be WGS-84. In the case that the data are transformed to WGS-84 from a local datum the responsible authority shall define the area where the local transformation parameters apply. Within this area, the difference between transformed coordinates and the surveyed WGS-84 coordinates may not exceed 0.5 m. For approval purposes, the responsible authority shall define appropriate reference points (surveyed WGS-84 coordinates) preferably exactly at the limit line of two adjacent areas. Reference points, transformation parameters and the algorithm shall be published and shall be the basis for Inland ENC production for that area.

### To 5.6.3 Data set files

A valid data set file must be uniquely identified world wide by its name.

The data set files are named according to the specifications given below:

CCPRRDDD.EEE

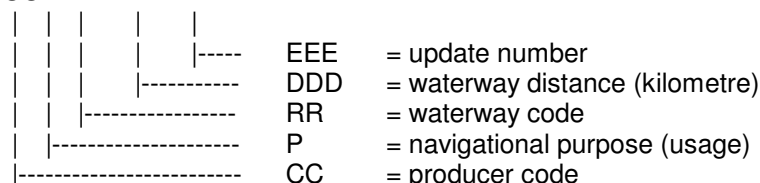

The main part forms an eight-character identifier where:

- The first two characters (CC) identify the producer. This list is given in Section 2, Appendix A, Annex A (Codes for Producers and Waterways).
- The third character (P) indicates the navigational purpose (see clause 2.1 of the IHO Product Specification). The letter “L” (in the position “usage”) indicates, that the cell is displayed as overlay over other cells within a range of usages. Overlay cells may not contain skin-of-the-earth objects. The range of usages of overlay cells is indicated in the Data Set Identification Field of the header of the overlay cell (see S57, Part 3, Data Structure, ch. 7.3.1.1). The 8<sup>th</sup> bit of the intended usage subfield (INTU) has to be set if a range is used, and the other seven bits describe the range (e.g. 79 means a range from usage 7 to usage 9).
- The fourth and fifth characters (RR) identify the waterway. (This list is also given in Section 2, Appendix A, Annex A).
- The sixth to eighth characters (DDD) are used for the waterway distance, e.g. if the cell covers the stretch from km 640 to km 650 the string will be “640”.

The primarily produced base cell file has the extension (EEE) 000.

The extension is used for updating. Update cell files have the same name as the original base cell file, with an extension number greater than or equal to 001. They cover the same geographical area as the base cell file to which they apply.

#### To 6.3.2.1 Data set identification field

Inland ENC are considered as an independent product besides ENC. To recognise a S-57 dataset as an Inland ENC the content of following two subfields has to be changed.

tag	subfield name	use	value	comment
PRSP	Product Specification	M	{10}	= European InlandENC, binary
PRED	Product Specification Edition Number	M	1.02	=ASCII

\* This is the edition number of the Inland ECDIS Standard

Edition 1.02  
16.10.2003

## **Standard**

# **Electronic Chart Display and Information System for Inland Navigation**

## **Inland ECDIS**

---

---

### **SECTION 2**

---

---

## **Data Standard for Inland ECDIS**

### **Annex A of Appendix B**

# **Use of the Object Catalogue for Inland ENC**

in addition to the

IHO-S-57 document  
"Use of the Object Catalogue"

## Contents

<b>1</b>	<b>General .....</b>	<b>113</b>
<b>2</b>	<b>Additions and Clarifications to the IHO Document "Use of the Object Catalogue" ....</b>	<b>114</b>
	to:	
4.4.1	Distance marks .....	114
4.4.2	Waterway axis .....	114
4.4.3	Waterway profile .....	114
4.4.4	Route planning point .....	114
4.5.3	Banks .....	114
4.6.1	Harbour facilities .....	115
4.6.2	Berths .....	116
4.6.3	Harbour offices .....	116
4.6.6.4	Gates (lock gates flood control gates) .....	116
4.6.7.3	Pontoons .....	116
4.6.12	Bunker stations .....	116
4.6.13	Refuse dumps .....	117
4.7.6	Rivers .....	117
4.8.1	Canals .....	117
4.8.10	Bridges .....	117
4.8.21	Signs and notice boards/marks .....	118
4.8.22	Locks .....	120
9.1.1	Administrative harbour areas .....	122
9.1.2	Harbour basin .....	122
10.2.6	Two-way routes .....	123
10.3	Ferries .....	124
11.1	Restricted areas in general .....	124
11.5.2	Overhead cables .....	124
11.6.3	Overhead pipelines .....	125
11.15.1	Achorage area (more ships) .....	125
11.15.2	Anchor berth (1 ship) .....	125
11.16	Turning basin .....	125
12.2	Buoyage system and direction of buoyage .....	126
12.3.1	Beacons .....	126
12.4.1	Buoys .....	126
12.6	Topmarks .....	126
12.12.	Radar conspicuous objects .....	126
12.13	Radio reporting (calling in) points .....	126
12.14	Communication area .....	127
13.4	Signal stations .....	127
<b>3</b>	<b>Index of Object Classes: .....</b>	<b>128</b>

## 1 General

This part of the Standard for Inland ECDIS specifies the conventions that are to be used to encode the geometry and semantic descriptions of each object in an Inland ENC.

The contents of an Inland ENC are at the discretion of the producing manufacturer provided that the regulations of the Standard for Inland ECDIS and by it of this document "Use of the Object Catalogue" are followed.

Chapter 2 of this document contains the additions and clarifications further to the IHO publication 'Use of the Object Catalogue for ENC' (S-57 Appendix B.1, Annex A) for Inland ECDIS (see References in Section 1, clause 2.2. of this standard for Inland ECDIS). The numbering and the layout correlate to S-57 Appendix B.1, Annex A.

The following printing conventions are used:

- |  |            |                |
|--|------------|----------------|
| • Copied object classes and Attributes from IHO-S-57 | upper case | ACRONYM        |
| • New object classes and Attributes                  | lower case | acronym        |
| • Object class:                                      |            | <b>ACRONYM</b> |
|  | bold       | <b>acronym</b> |
| • Attribute  | thin       | ACRONYM        |
|  |            | Acronym        |
- Set\_Attributes A: For each object class, the whole list of Attributes of set A is given with the specific values for this feature object.
  - Set\_Attributes B, Set\_Attributes C: Except for attributes INFORM, NINFOM, and more rarely SORDAT, the attributes from sets B and C are not mentioned in the following lists; however, this does not mean that their use is prohibited.







**To 4.6.2 Berths**

Geo object: berth (**berths**)

Attributes:	catbrt	comctn	DATEND	DATSTA	DRVAL1
	NOBJNM	OBJNAM	PEREND	PERSTA	QUASOU
	SOUACC	STATUS	VERDAT	INFORM	NINFOM

Berths may also be located at the river side (see Figure 10).

**To 4.6.3 Harbour offices**

Harbour offices are no longer encoded as **BUISGL** but as **hrbfac**.

**To 4.6.6.4 Gates (lock gates flood control gates)**

A gate must be covered by a **DRGARE**.

**To 4.6.7.3 pontoons**

Pontoons whose size is not sufficient to create an area object must be encoded as point **SLCONS** with CATSLC=4 (pier/jetty).

**New 4.6.11 Ship yards**

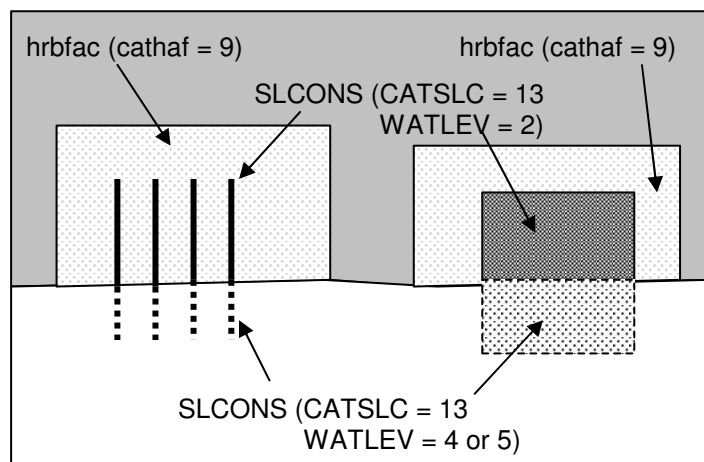

**Figure 2 – ship yards**

The production area on shore is always encoded as **hrbfac** with cathaf = 9. The slipways are encoded as **SLCONS** with CATSLC = 13 and the respective WATLEV attribute. The limit line between water and land is encoded as **rivbnk**, **canbnk** or **SLCONS**.

**New 4.6.12 Bunker stations**

Geo object: bunker station (**bunsta**)

Attributes:	bunves	catbun	comctn	TIMEND	TIMSTA
	NOBJNM	OBJNAM	INFORM	NINFOM	

#### 4.6.13 Refuse dumps

Geo object: berth (**refdmp**)

Attributes: catdmp comctn TIMEND TIMSTA NOBJNM  
OBJNAM INFORM NINFOM

#### To 4.7.6 Rivers

For Inland ECDIS data rivers are mostly navigable at compilation scale. They must be encoded as **DE-PARE** or **DRGARE** and the river banks must be encoded as **rivbnk**. The object class **RIVERS** may only be used for rivers which are not navigable at compilation scale.

#### To 4.8.1 Canals

For Inland ECDIS data canals are mostly navigable at compilation scale. They must be encoded as **DE-PARE** or **DRGARE** and the canal banks must be encoded as **canbnk**. The object class **CANALS** may only be used for canals which are not navigable at compilation scale.

#### To 4.8.10 Bridges

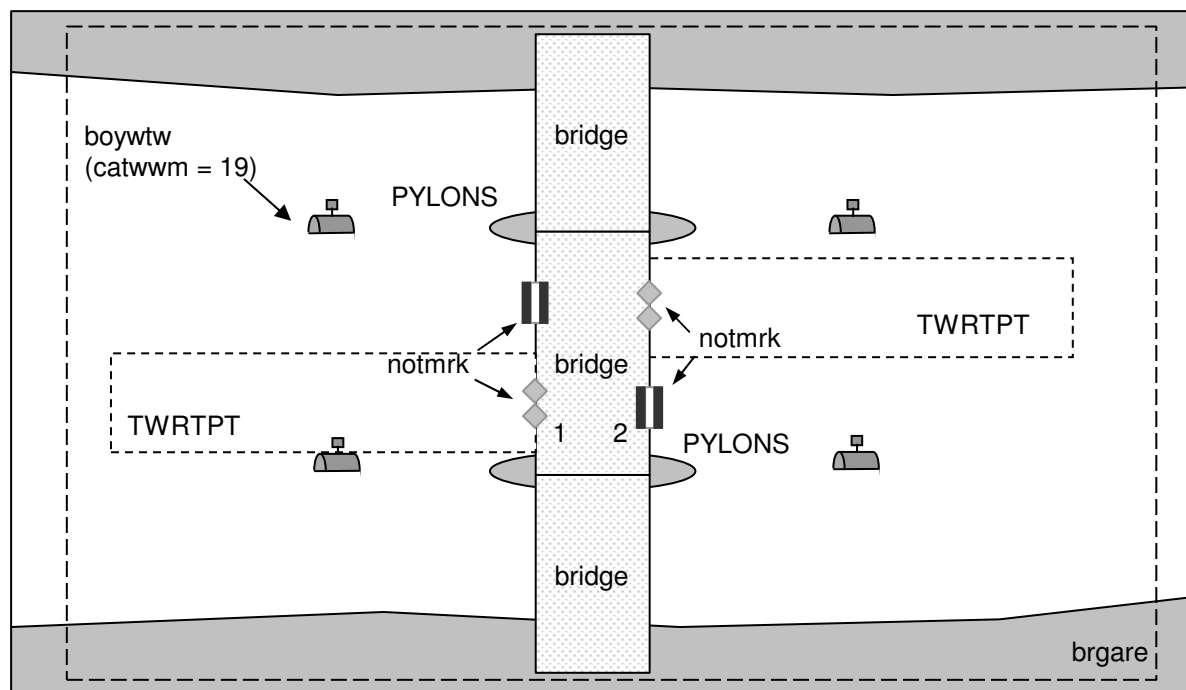

Figure 3 - Bridges

##### New 4.8.10.1 Bridge area

A bridge area covers the entire area, in which the bridge itself, the bridge supports and any bridge traffic regulations are located.

Geo object: bridge area (**brgare**)

Attributes: comctn NOBJNM OBJNAM INFORM NINFOM

### New 4.8.10.2 Bridge

Each part of a bridge with different properties, e.g. categories or vertical clearances, has to be encoded as a single bridge object.

Geo object: bridge (**bridge**)

Attributes:	catbrg	comctn	COLOUR	COLPAT	CONDTN
	CONRAD	CONVIS	DATEND	DATSTA	HORACC
	HORCLR	NATCON	NOBJNM	OBJNAM	TIMEND
	TIMSTA	VERACC	VERCCL	VERCLR	VERCOP
	verdat				

**notmrk** (notice mark) and **TWRTPT** (two way route part) shall be used for the indication of traffic direction in navigable waters under bridges. The opening times can be encoded with the attributes **TIMSTA** and **TIMEND**.

### New 4.8.10.3 Pylons and bridge supports

Geo object: Pylon / bridge support (**PYLONS**)

Attributes:	CATPYL	COLOUR	COLPAT	CONDTN	CONRAD	CONVIS	DATEND
	DATSTA	HEIGHT	NATCON	NOBJNM	OBJNAM	VERLEN	WATLEV
	INFORM	NINFOM					

Area **PYLONS** must be covered by an area **LNDARE**

### New 4.8.21 Signs and notice boards/marks

Notice boards which are used only for inland water navigation have to be encoded as notice marks.

Geo object: notice mark (**notmrk**)

Attributes:	catnmk	fncnmk	dirimp	disipd	disipu
	disbk1	disbk2	addmrk	ORIENT	CONDTN
	NOBJNM	OBJNAM	STATUS	INFORM	NINFOM

Normally a pair of notice marks describes an area. To define this area the direction of impact and the distances are used, which are normally given by additional marks. For notice marks on bridges the attribute **ORIENT** has to be used as well, to rotate the symbol according the orientation of the bridge. The value of **ORIENT** at bridges should correspondent to the prescribed heading of the vessels.

Table 1 - Notice marks and their related areas:

code number	Point / Area	Area of impact	Area Feature object	Area Feature attributes	remarks
A1	P				at bridges or locks
A1	A		resare	restrn = 1	
A2-A4	A	bank to bank	resare	restrn = 16,17	
A5-A7	A	bank to fairway	resare	restrn = 1,18	
A8-A9	A	bank to bank	resare	restrn = 20,13	
A10	P				only at bridges (ORIENT)
A13-A18	P				
B1-B5	P				
B6	A	bank to bank	resare	restrn = 21	
B7-B11	P				
C1-C3	A		resare	restrn = 22,23	
C4	P,A				depending on add. inform.
C5	A	bank to distance	resare	restrn = 7	distance given on notmrk
D1-D2	P				only at bridges (ORIENT)
D3	P				
E1	P				only at bridges (ORIENT)
E2-E4	P				
E.5	A		berths, achare	clsdng, catach, clsdng	berthing area; symbolization by an „anchor“ or „circle with the number of the berthing area“
E.6	A		achare	catach, clsdng	anchoring
E.7	A		berths	catbrt,clsdng	making fast to the bank
E.8	A		trnbsn		
E.9-E.14	P				
E.15-E.22	A	bank to fairway	CTNARE	INFORM	

Table 2 - Notice marks at bridges (see Figure 3):

no	fnctnm	catnmk	addmrk	dirimp	disipu	disipd	disbk1	disbk2	ORIENT
1	recom. = 2	D1b = 45	-	-	-	-	-	-	90
2	proh. = 1	A1 = 1	-	-	-	-	-	-	90

Table 3 - Notice marks at restricted areas (see Figure 10):

no	fnctnm	catnmk	addmrk	dirimp	disipu	disipd	disbk1	disbk2	INFORM
1	regul. = 2	B11 = 37	4	downstr.	-	-	-	-	VHF 11
2	restr. = 3	C5 = 42,43	4	downstr.	-	120	-	40	-
3	proh. = 1	A6 = 8	-	-	-	-	-	-	-
4	inform. = 5	E11 = 90	-	-	-	-	-	-	-
5	proh. = 1	A2 = 4	-	downstr.	-	-	-	-	-
6	regul. = 2	B6 = 32	3	downstr.	-	-	-	-	6 km/h
7	inform. = 5	E17 = 95	4	upstr.	-	-	-	-	-
8	inform. = 5	C4 = 41	3	downstr.	-	-	-	-	-

**Table 4 - Notice marks at anchorages and berths (see Figure 11):**

no	fnctnm	catnmk	addmrk	dirimp	disipu	disipd	disbk1	disbk2	INFORM
1	inform. = 5	C4 = 41	2,3	upstr.	-	-	-	-	Reede
2	inform. = 5	E5.4 = 59	3	upstr.	200	-	-	-	-
3	inform. = 5	E5.4 = 59	4	downstr.	-	200	-	-	-
4	inform. = 5	E5.9 = 64	2,3	upstr.	-	-	30	80	-
5	inform. = 5	E5.9 = 64	2,4	downstr.	-	-	40	90	-
6	inform. = 5	C4 = 41	2,4	downstr.	-	-	-	-	Reede

**New 4.8.22 Locks**

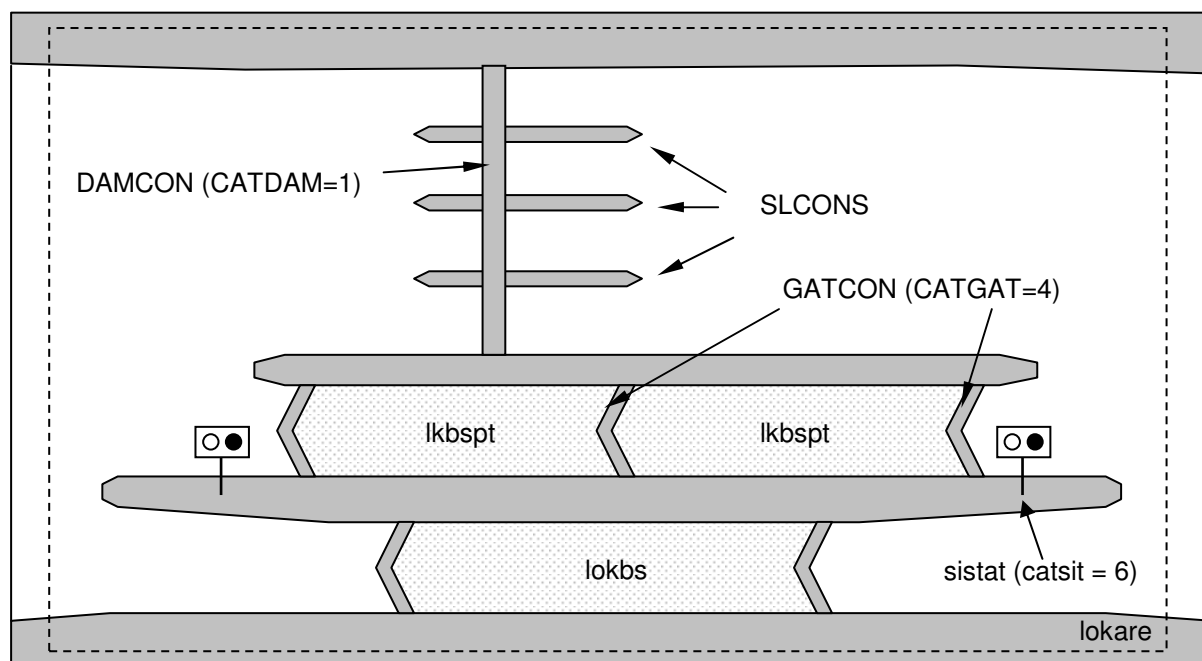

**Figure 4 - locks**

**New 4.8.22.1 Lock area**

The lock area covers the entire area in which all lock buildings are located.

Geo object: lock area (**lokare**)

Attributes: comctn      NOBJNM      OBJNAM      STATUS      INFORM  
NINFOM

#### New 4.8.22.2 Lock basin

Geo object: lock basin (**lokbsn**)

Attributes: HORACC horcll horclw HORLEN HORWID  
NOBJNM OBJNAM STATUS INFORM NINFOM

The lock basin must be covered by a depth area (DEPARE) with depth = waterway fairway depth. The horizontal length and width (HORLEN and HORWID) are the physical distances given by the building itself. The usable horizontal clearance of length and width (horcll and horclw) are distances which are provided by the competent authority for safe navigation. The opening times can be encoded with the attributes **TIM-STA** and **TIMEND**.

#### New 4.8.22.3 Lock basin part

If a lock basin has more than two gates and the ground level is the same, than different lock basin parts must be created.

Geo object: lock basin part (**lkbspt**)

Attributes: HORACC horcll horclw HORLEN HORWID  
NOBJNM OBJNAM STATUS INFORM NINFOM

The lock basin part must be covered by a DEPARE.

### To 5 Depths

As long as depths shall not be updated to the current water level the object class DEPARE must be used to encode depths. The object class **depare** is only to be used when time variable depths below actual water levels are needed. The object class **depare** is a part of Group 1.

Geo object: Depth area (**depare**)

Attributes: DRVAL1 DRVAL2 eleva1 eleva2 verdat  
wtwdis QUASOU INFORM NINFOM

The attributes eleva1 and eleva2 are used to define the elevation of the bottom of a river or canal. The attribute **verdat** only applies to the attributes **eleva1** and **eleva2**. The attribute **wtwdis** is used for the application of any water level models.

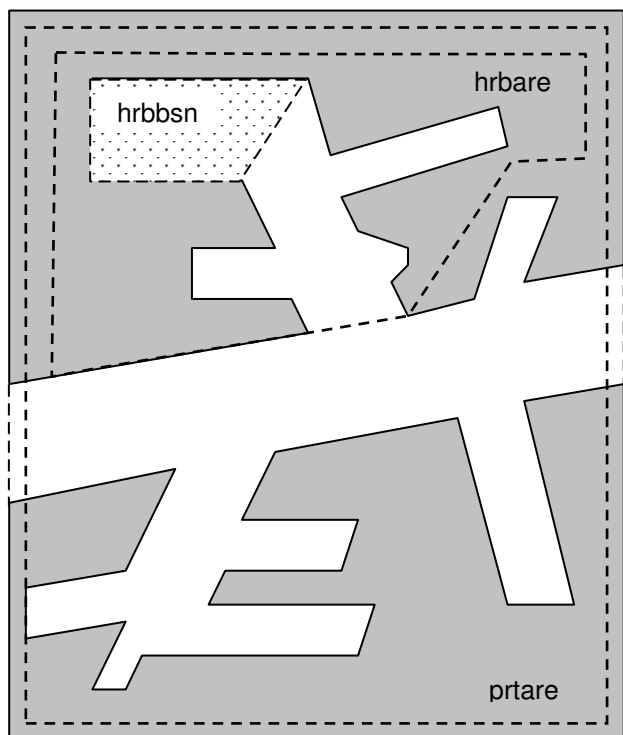

Figure 5 – port area

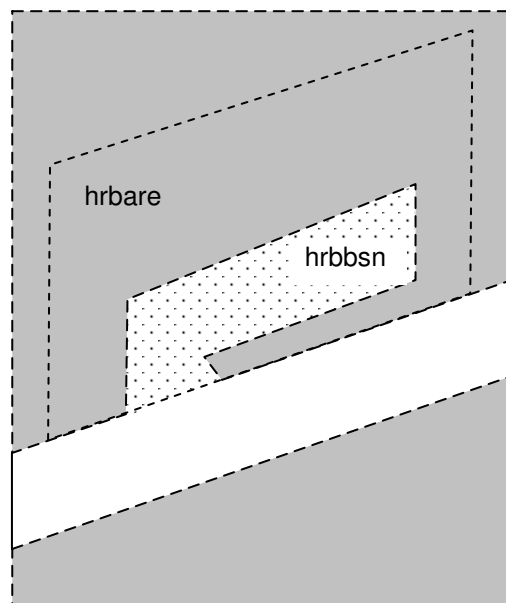

Figure 6 – harbour area

### To 9.1.1 Administrative harbour areas

#### New 9.1.1.1 Port Area

Geo object: port area (**prtare**)

Attributes: comctn NOBJNM OBJNAM STATUS INFORM  
NINFOM

#### New 9.1.1.2 Harbour Area

Geo object: harbour area (**hrbare**)

Attributes: cathbr comctn NOBJNM OBJNAM STATUS  
INFORM NINFOM

The port area covers the entire area of a city's harbour areas, harbour basins, terminals and harbour facilities. Normally it applies only to big international ports.

#### New 9.1.2 Harbour basin

Geo object: harbour basin (**hrbbsn**)

Attributes: HORACC HORLEN HORWID NOBJNM OBJNAM  
STATUS INFORM NINFOM

A harbour basin is bordered by shoreline constructions and the entrance to the basin.



**To 10.2.6 Two-way routes**

A two-way route in inland waterways regulates the flow of traffic at bridges or fairway separations.

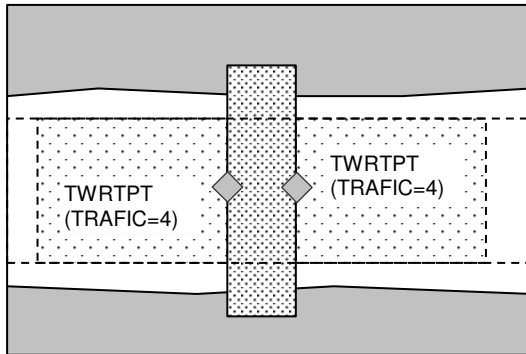

**Figure 7 - Two-way route part at bridges**

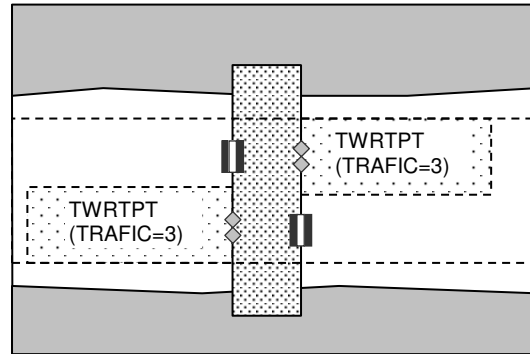

**Figure 8 - Two-way route part at bridges**

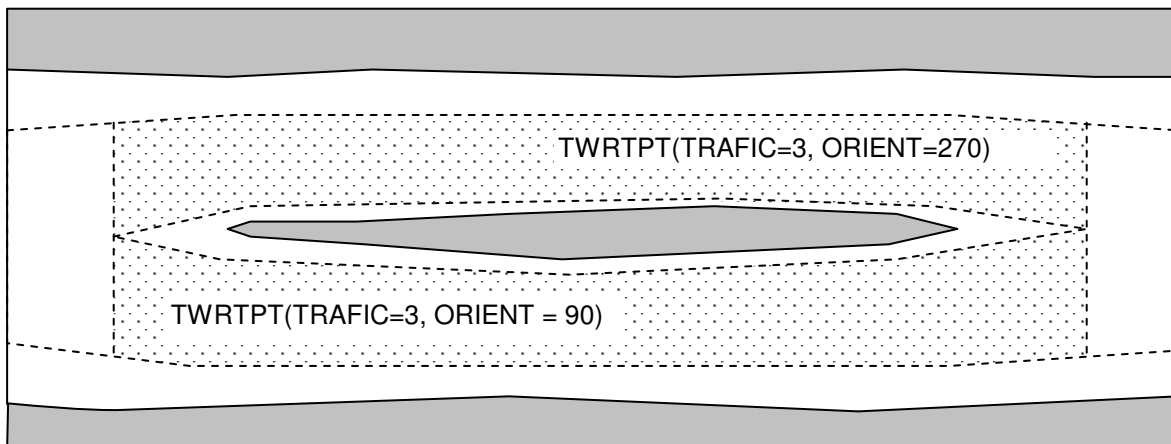

**Figure 9 – Two-way route parts at a fairway separation**

Geo object: Two-way route part (**TWRTPT**)

Attributes: CATTRK DATEND DATSTA DRVAL1 ORIENT QUASOU  
 SOUACC STATUS TECSOU TRAFIC INFORM NINFOM

A two-way route part in front of or behind a bridge should be at least as long as the fairway is wide.

### To 10.3 Ferries

Geo object: Ferry route (**feryrt**)

Attributes: catfry comctn DATEND DATSTA NOBJNM OBJNAM  
PEREND PERSTA STATUS INFORM NINFOM

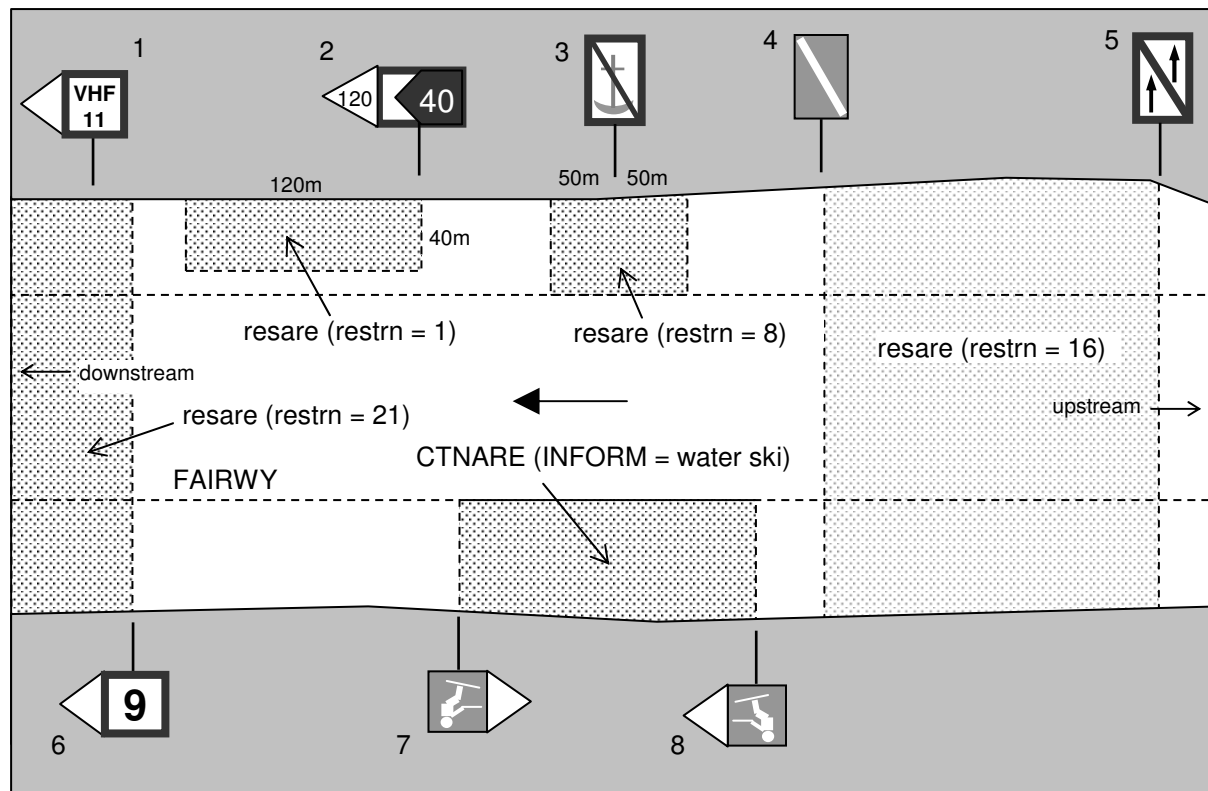

Figure 10 – Restricted Areas in general

### To 11.1 Restricted areas in general

If the restriction is a special inland waterway restriction the object class **resare** has to be used.

Geo object: restricted area (**resare**)

Attributes: CATREA DATEND DATSTA NOBJNM OBJNAM  
PEREND PERSTA restrn STATUS INFORM  
NINFOM

### To 11.5.2 Overhead cables

If the cables have a special inland water vertical datum the object class **cblohd** has to be used.

Geo object: Cable overhead (**cblohd**)

Attributes: CATCBL CONDTN CONRAD CONVIS DATEND DATSTA ICEFAC  
NOBJNM OBJNAM STATUS VERACC VERCLR VERCSA **verdat**  
INFORM NINFOM

### To 11.6.3 Overhead pipelines

If the cables have a special inland water vertical datum the object class PIPOHD has to be used.

Geo object: Pipeline overhead (PIPOHD)

Attributes: CATPIP CONDTN CONRAD CONVIS DATEND DATSTA NOBJNM  
OBJNAM PRODC T STATUS VERACC VERCLR **verdat** INFORM  
NINFORM

### New 11.15 Berthing areas

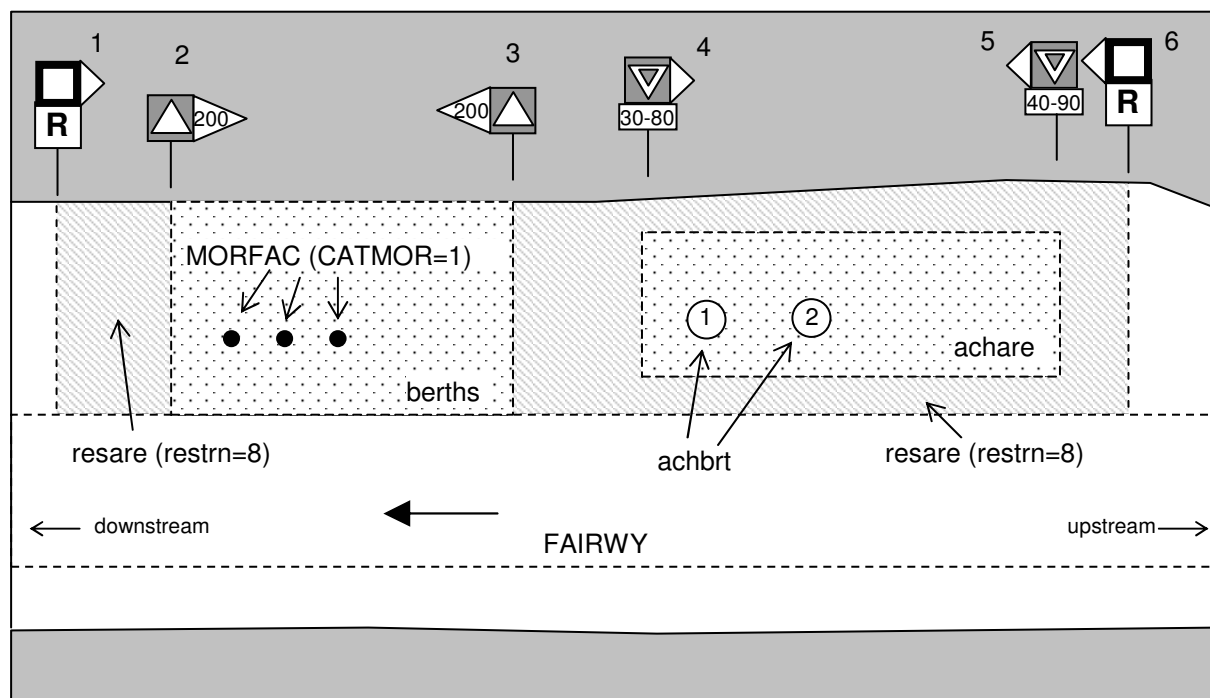

**Figure 11 –berthing areas**

#### New 11.15.1 Anchorage area (more ships)

Geo object: Anchorage area (**achare**)

Attributes: catach clsdng DATEND DATSTA NOBJNM  
OBJNAM PEREND PERSTA RESTRN STATUS  
INFORM NINFOM

#### New 11.15.2 Anchor berth (1 ship)

Geo object: Anchor berth (**achbrt**)

Attributes: catbrt clsdng DATEND DATSTA NOBJNM  
OBJNAM PEREND PERSTA RESTRN STATUS  
INFORM NINFOM

#### New 11.16 Turning basin

Geo object: Turning basin (**trnbsn**)

Attributes: HORCLR NOBJNM OBJNAM INFORM NINFOM

### To 12.2 Buoyage system and direction of buoyage

The buoyage system and, where necessary, the direction of buoyage are encoded with the meta object **m\_nsys**.

Meta object: Navigational system of marks (**m\_nsys**)

Attributes: **marsys** ORIENT INFORM NINFOM

### To 12.3.1 Beacons

Inland waterway beacons are encoded as **bcnwtw**.

Geo objects: Beacon waterway (**bcnwtw**)

Attributes: BCNSHP catwwm COLOUR COLPAT CONDTN  
CONRAD CONVIS DATEND DATSTA ELEVAT  
HEIGHT marsys - NATCON NOBJNM OBJNAM  
PEREND PERSTA STATUS VERLEN INFORM  
NINFOM

The attribute marsys may only be defined if it is different to the value encoded in **m\_nsys**.

### To 12.4.1 Buoys

Inland waterway buoys are encoded as **boywtw**.

Geo objects: Buoy waterway (**boywtw**)

Attributes: BOYSHP catwwm COLOUR COLPAT CONRAD  
DATEND DATSTA marsys - NATCON NOBJNM  
OBJNAM PEREND PERSTA STATUS INFORM  
NINFOM

The attribute marsys may only be defined if it is different to the value encoded in **m\_nsys**.

## 12.6 Topmarks

Geo object: Topmark (**topmar**)

Attributes: COLOUR COLPAT marsys STATUS TOPSHP INFORM NINFOM

### To 12.12 Radar conspicuous objects

For the use of radar matching systems the following object classes have to be defined as radar conspicuous:

**bcnwtw bridge boywtw cblohd canbnk FLODOC**  
**PYLONS rivbnk SLCONS**

### To 12.13 Radio reporting (calling in) points

Geo object: Radio calling-in point (**rdocal**)

---

Attributes:    catcom    COMCHA    DATEND    DATSTA    NOBJNM    OBJNAM    ORIENT  
                 PEREND    PERSTA    STATUS    TRAFIC    INFORM    NINFOM

**To 12.14      Communication area**

Geo object:    Communication area (**comare**)

Attributes:    catcom    COMCHA    DATEND    DATSTA    NOBJNM    OBJNAM  
                 STATUS    TRAFIC    INFORM

**To 13.4      Signal stations**

Signal stations which control the traffic are encoded as **sistat**, e. g. lock signals or wahrschau signals.

Geo object:    signal station, traffic (**sistat**)

Attributes:    catsit  
                 COMCHA    DATEND    DATSTA    NOBJNM    OBJNAM    PEREND    PERSTA  
                 STATUS    INFORM    NINFOM

Signal stations where the skipper gets information on the conditions which influence his voyage, e.g. water levels, weather in general, are encoded as signal stations, warning **sistaw**.

Geo object:    signal station, warning (**sistaw**)

Attributes:    catsiw  
                 COMCHA    DATEND    DATSTA    NOBJNM    OBJNAM    PEREND    PERSTA  
                 STATUS    INFORM    NINFOM

The building housing the service is encoded as a **BUISGL** or **LNDMRK**.

### 3 Index of Object Classes:

#### A

achare..... 114, 119, 125  
achbrt ..... 114, 125

#### B

bcnwtw ..... 126, 127  
berths ..... 114, 116  
boywtw ..... 126, 127  
brgare ..... 118  
bridge ..... 114, 118, 127  
BUAARE ..... 114  
BUISGL ..... 116, 127  
bunsta ..... 114, 117

#### C

canbnk..... 115, 116, 117, 127  
cblohd ..... 114, 124, 125, 127  
comare ..... 127

#### D

depare ..... 121  
DEPARE ..... 117, 127  
dismar ..... 114  
DRGARE..... 116, 117, 121

#### F

feryrt ..... 123  
FLODOC ..... 127

#### H

hrbare ..... 114, 122  
hrbbsn ..... 114, 122  
hrbfac ..... 115, 116

#### L

lkbspt..... 114, 121  
LNDARE ..... 118  
LNDMRK..... 127  
lokare ..... 120  
lokbsn..... 114, 121

#### M

m\_nsys ..... 126

#### N

notmrk ..... 118

#### P

pipohd..... 125  
prtare ..... 114, 122  
PYLONS..... 118, 127

#### R

rdocal..... 127  
refdmp ..... 114, 117  
resare ..... 119, 125  
rivbnk..... 115, 116, 117, 127  
RIVERS ..... 117  
rtplpt ..... 114

#### S

sistat ..... 127  
sistaw..... 127  
SLCONS..... 116, 122, 127

#### T

termnl..... 114, 115  
topmar ..... 126  
trnbsn ..... 114, 119, 126  
TWRTPT ..... 118, 123

#### W

wtwaxs..... 114  
wtwprf..... 114

Edition 1.02  
16.10.2003

## **Standard**

# **Electronic Chart Display and Information System for Inland Navigation**

## **Inland ECDIS**

---

---

### **SECTION 3**

---

---

# **Presentation Standard for Inland ECDIS**

## **Contents**

Presentation Standard

Appendix A            Presentation Library for Inland ECDIS



## Presentation Standard

1. This "Presentation Standard for Inland ECDIS" describes the standard to be used for the presentation of Inland ECDIS data. The presentation has to take place in such a way that none of the information is lost.
2. This Presentation Standard is based on the document "S-52, Specification for Chart Content and Display Aspects of ECDIS" of the IHO, Edition 5.0 of December 1996, with all Appendices and Annexes (see table "Comparison of the structures of the standards for (Maritime) ECDIS and Inland ECDIS" in Section 0 of this Standard for Inland ECDIS).
3. This Presentation Standard describes the necessary additions and clarifications to S-52 and the application of S-52 for the purpose of use in Inland ECDIS applications.
4. This Presentation Standard is organized as follows:
  - this section 2 of the Inland ECDIS Standard,
  - Appendix A "Presentation Library for Inland ECDIS" with additions and clarifications to be applied to S-52, Appendix 2, Annex A.
5. Definitions of terms may be found in
  - IHO-S-57, Part 1, clause 5,
  - the "Glossary of ECDIS-Related Terms" in Appendix 3 to S-52,
  - the "Glossary for Inland ECDIS" in Section 5 of this Inland ECDIS Standard.
6. Section 2 (Data Standard), ch. 5 of this Inland ECDIS Standard shall be applied also for the maintenance of this Presentation Standard.

*Page 132 intentionally left empty*

Edition 1.02  
16.10.2003

## **Standard**

# **Electronic Chart Display and Information System for Inland Navigation**

## **Inland ECDIS**

---

---

### **SECTION 3**

---

---

## **Presentation Standard for Inland ECDIS**

## **Appendix A**

# **Presentation Library for Inland ECDIS**

In addition to the

IHO-S-52 Presentation Library

## Contents

<b>1</b>	<b>Introduction</b> .....	135
<b>2</b>	<b>Presentation Library (Preslib)</b> .....	135
2.1	Look-up tables .....	136
2.2	Symbols .....	136
2.3	Conditional symbology procedures (CS) .....	136
2.4	Colours .....	136
<b>3</b>	<b>Extensions to the Look-up Tables of IHO-S-52</b> .....	137
3.1	New entries for Inland ECDIS object classes .....	137
3.1.1	Points: .....	137
3.1.2	Lines .....	139
3.1.3	Areas .....	140
3.2	Extended entries for S-57 object classes .....	141
3.2.1	Areas .....	141
<b>4</b>	<b>Extensions of conditional symbology procedures (CS)</b> .....	141
4.1	Top marks .....	141
4.2	Restricted areas .....	141
4.3	Lights .....	141
4.4	Notice marks .....	141
<b>5</b>	<b>Extensions to the Symbol Library</b> .....	142
5.1	New symbols to be shown on the chart display (simplified point symbols) .....	142
5.1.1	Raster symbols .....	142
5.1.2	Vector symbols (must be rotated, the numbers refer to CEVNI) .....	143
5.2	New symbols to be shown in the "information window on notice marks" .....	143
<b>6</b>	<b>Presentation of notice marks</b> .....	145
<b>7</b>	<b>Presentation of objects for radar map matching</b> .....	146
<b>8</b>	<b>Inland ECDIS symbols</b> .....	147
8.1	Raster symbols .....	147
8.1.1	Symbols in general .....	147
8.1.2	Navigational aids .....	148
8.1.3	Harbour facilities, terminals .....	149
8.2	Symbols for the "information window on notice marks" .....	150
8.3	Vector symbols .....	155

## 1 Introduction

S-57 data sets do not contain any information about how it is going to be presented. The chart is generated online in the ECDIS application. For that purpose, the ECDIS application uses machine readable symbolization instructions for each object which are drawn on the screen and form the chart image. The S-52 standard contains all rules which are necessary for the symbolization and presentation of S-57 data on the screen. The symbolization depends on a number of parameters the user may change during runtime. That requires that not only colour and symbol definitions are available but also procedures which allow a dynamic change of presentation.

The ECDIS symbolization also must allow five different levels of brightness in order to cope with different light conditions on the bridge of the ship.

## 2 Presentation Library (Preslib)

The major components of the presentation library are:

- A library of symbols, line styles and fill styles
- A colour coding scheme which includes the IHO colour tables for day and night time
- A set of symbology command words from which machine readable instructions can be assembled. The result is a symbology instruction which is processed to symbolise S-57 objects in turn.
- A set of conditional symbology procedures to decide the appropriate symbolisation in cases determined by the mariner's selection (e.g. safety contour) or for complex symbols (e. g. topmarks on buoys and beacons)
- A set of look-up tables that link object descriptions from the SENC database to the appropriate symbology instructions depending on whether:
  - a) the link is straight forward, i.e. a direct relationship between an object's description and its presentation such as a buoy or a land area. In this case, the look-up table provides the symbology instruction to show a symbol, an area fill, or a line style.
  - b) the link is conditional, i.e. depending on circumstances, for example a depth area, whose colour fill depends on the choice of the safety contour. In this case the look-up table refers the decision to a conditional symbology procedure that selects the appropriate symbology instructions later.

## 2.1 Look-up tables

For each geometry type (point, line, area) and its respective symbolization type (for points: traditional and simplified) there is a separate look-up table. Each entry in a look-up table consists of the following fields:

1. 6-character code of the object class (acronym)
2. Attribute combination
3. Symbolization instructions
4. Display priority, 0-9 (comparable with drawing layers)
5. Radar code
6. Display category (Display base, standard, all other)
7. "Viewing group", more refined grouping of objects than the display categories

```
"LNDMRK","CATLMK17|","SY(TOWERS01)","7","O","OTHER","32250"
```

**Figure 1 - Example entry of a look-up table**

In this case the object LNDMRK is shown by the symbol TOWERS01 with priority 7, if the attribute CATLMK equals 17. The object lies over the radar.

In Inland ECDIS, the simplified type of symbolization of points is used only.

The presentation of objects in a specific area, that are contained in different cells of the same usage, follows the entries in the look-up tables.

## 2.2 Symbols

Symbols can be defined in vector format or in raster format. Symbols which will be rotated must be defined in vector format. The size of vector symbols is adapted automatically to the resolution and size of the screen. In case of raster symbols, different symbol sets must be designed to meet the requirements of a readable display.

## 2.3 Conditional symbology procedures (CS)

CS are generated for objects of which the symbolization

- depends on application settings, e.g. safety contour,
- depends on other objects, e.g. top marks and their structure,
- is too complex to be defined in a direct look-up table entry.

## 2.4 Colours

Colours used in an ECDIS are defined in an absolute, monitor independent way (CIE coordinates). This ensures that ECDIS charts look similar on monitors of different suppliers. By means of a colour calibration software which must be used by the manufacturer, CIE values are converted into RGB values. Because of

the different light conditions on the bridge of a ship, it is necessary to offer presentations with different brightness. For each level a separate colour table exists.

### 3 Extensions to the Look-up Tables of IHO-S-52

#### 3.1 New entries for Inland ECDIS object classes

##### Points:

"achare", "", "SY(ACHARE02)", "60", "O", "STANDARD", "26220"  
"achbrt", "", "SY(ACHBRT07);TX(OBJNAM,3,1,2,'14106',1,0,CHBLK,29)", "50", "O", "STANDARD", "26220"  
"bcnwtw", "", "SY(BCNLAT50);TX(OBJNAM,2,1,2,'14106',-1,-1,CHBLK,21)", "80", "O", "DISPLAYBASE", "17020"  
"berths", "", "SY(BRTHNO01);TX(OBJNAM,1,2,3,'14108',0,0,CHMGD,29)", "60", "O", "STANDARD", "22440"  
"boywtw", "", "SY(BOYDEF03);TX(OBJNAM,2,1,2,'14106',-1,-1,CHBLK,21)", "80", "O", "DISPLAYBASE", "17010"  
"boywtw", "catwmm4|COLOUR3|", "SY(BOYLAT50);TX(OBJNAM,2,1,2,'14106',-1,-1,CHBLK,21)", "80", "O", "DISPLAYBASE", "17010"  
"boywtw", "catwmm5|COLOUR4|", "SY(BOYLAT51);TX(OBJNAM,2,1,2,'14106',-1,-1,CHBLK,21)", "80", "O", "DISPLAYBASE", "17010"  
"boywtw", "catwmm6|COLOUR3,4|", "SY(BOYLAT54);TX(OBJNAM,2,1,2,'14106',-1,-1,CHBLK,21)", "80", "O", "DISPLAYBASE", "17010"  
"boywtw", "catwmm6|COLOUR4,3|", "SY(BOYLAT54);TX(OBJNAM,2,1,2,'14106',-1,-1,CHBLK,21)", "80", "O", "DISPLAYBASE", "17010"  
"boywtw", "catwmm7|COLOUR1,3|", "SY(BOYLAT55);TX(OBJNAM,2,1,2,'14106',-1,-1,CHBLK,21)", "80", "O", "DISPLAYBASE", "17010"  
"boywtw", "catwmm7|COLOUR3,1|", "SY(BOYLAT55);TX(OBJNAM,2,1,2,'14106',-1,-1,CHBLK,21)", "80", "O", "DISPLAYBASE", "17010"  
"boywtw", "catwmm7|COLOUR3,4,3|", "SY(BOYLAT52);TX(OBJNAM,2,1,2,'14106',-1,-1,CHBLK,21)", "80", "O", "DISPLAYBASE", "17010"  
"boywtw", "catwmm8|COLOUR1,4|", "SY(BOYLAT56);TX(OBJNAM,2,1,2,'14106',-1,-1,CHBLK,21)", "80", "O", "DISPLAYBASE", "17010"  
"boywtw", "catwmm8|COLOUR4,1|", "SY(BOYLAT56);TX(OBJNAM,2,1,2,'14106',-1,-1,CHBLK,21)", "80", "O", "DISPLAYBASE", "17010"  
"boywtw", "catwmm8|COLOUR4,3,4|", "SY(BOYLAT53);TX(OBJNAM,2,1,2,'14106',-1,-1,CHBLK,21)", "80", "O", "DISPLAYBASE", "17010"  
"boywtw", "catwmm9|COLOUR1,3|", "SY(BOYLAT55);TX(OBJNAM,2,1,2,'14106',-1,-1,CHBLK,21)", "80", "O", "DISPLAYBASE", "17010"  
"boywtw", "catwmm9|COLOUR3,1|", "SY(BOYLAT55);TX(OBJNAM,2,1,2,'14106',-1,-1,CHBLK,21)", "80", "O", "DISPLAYBASE", "17010"  
"boywtw", "catwmm9|COLOUR3,4,3|", "SY(BOYLAT52);TX(OBJNAM,2,1,2,'14106',-1,-1,CHBLK,21)", "80", "O", "DISPLAYBASE", "17010"  
"boywtw", "catwmm10|COLOUR1,4|", "SY(BOYLAT56);TX(OBJNAM,2,1,2,'14106',-1,-1,CHBLK,21)", "80", "O", "DISPLAYBASE", "17010"  
"boywtw", "catwmm10|COLOUR4,1|", "SY(BOYLAT56);TX(OBJNAM,2,1,2,'14106',-1,-1,CHBLK,21)", "80", "O", "DISPLAYBASE", "17010"  
"boywtw", "catwmm10|COLOUR4,3,4|", "SY(BOYLAT53);TX(OBJNAM,2,1,2,'14106',-1,-1,CHBLK,21)", "80", "O", "DISPLAYBASE", "17010"  
"boywtw", "catwmm11|COLOUR1,3|", "SY(BOYLAT55);TX(OBJNAM,2,1,2,'14106',-1,-1,CHBLK,21)", "80", "O", "DISPLAYBASE", "17010"  
"boywtw", "catwmm11|COLOUR3,1|", "SY(BOYLAT55);TX(OBJNAM,2,1,2,'14106',-1,-1,CHBLK,21)", "80", "O", "DISPLAYBASE", "17010"  
"boywtw", "catwmm12|COLOUR1,4|", "SY(BOYLAT56);TX(OBJNAM,2,1,2,'14106',-1,-1,CHBLK,21)", "80", "O", "DISPLAYBASE", "17010"  
"boywtw", "catwmm12|COLOUR4,1|", "SY(BOYLAT56);TX(OBJNAM,2,1,2,'14106',-1,-1,CHBLK,21)", "80", "O", "DISPLAYBASE", "17010"  
"boywtw", "catwmm13|COLOUR1,3|", "SY(BOYLAT55);TX(OBJNAM,2,1,2,'14106',-1,-1,CHBLK,21)", "80", "O", "DISPLAYBASE", "17010"  
"boywtw", "catwmm13|COLOUR3,1|", "SY(BOYLAT55);TX(OBJNAM,2,1,2,'14106',-1,-1,CHBLK,21)", "80", "O", "DISPLAYBASE", "17010"  
"boywtw", "catwmm13|COLOUR3,4,3|", "SY(BOYLAT52);TX(OBJNAM,2,1,2,'14106',-1,-1,CHBLK,21)", "80", "O", "DISPLAYBASE", "17010"  
"boywtw", "catwmm14|COLOUR1,4|", "SY(BOYLAT56);TX(OBJNAM,2,1,2,'14106',-1,-1,CHBLK,21)", "80", "O", "DISPLAYBASE", "17010"  
"boywtw", "catwmm14|COLOUR4,1|", "SY(BOYLAT56);TX(OBJNAM,2,1,2,'14106',-1,-1,CHBLK,21)", "80", "O", "DISPLAYBASE", "17010"  
"boywtw", "catwmm14|COLOUR4,3,4|", "SY(BOYLAT53);TX(OBJNAM,2,1,2,'14106',-1,-1,CHBLK,21)", "80", "O", "DISPLAYBASE", "17010"  
"boywtw", "catwmm15|COLOUR1,3|", "SY(BOYLAT55);TX(OBJNAM,2,1,2,'14106',-1,-1,CHBLK,21)", "80", "O", "DISPLAYBASE", "17010"  
"boywtw", "catwmm15|COLOUR3,1|", "SY(BOYLAT55);TX(OBJNAM,2,1,2,'14106',-1,-1,CHBLK,21)", "80", "O", "DISPLAYBASE", "17010"  
"boywtw", "catwmm15|COLOUR3,4,3|", "SY(BOYLAT52);TX(OBJNAM,2,1,2,'14106',-1,-1,CHBLK,21)", "80", "O", "DISPLAYBASE", "17010"  
"boywtw", "catwmm16|COLOUR1,4|", "SY(BOYLAT56);TX(OBJNAM,2,1,2,'14106',-1,-1,CHBLK,21)", "80", "O", "DISPLAYBASE", "17010"  
"boywtw", "catwmm16|COLOUR4,1|", "SY(BOYLAT56);TX(OBJNAM,2,1,2,'14106',-1,-1,CHBLK,21)", "80", "O", "DISPLAYBASE", "17010"  
"boywtw", "catwmm16|COLOUR4,3,4|", "SY(BOYLAT53);TX(OBJNAM,2,1,2,'14106',-1,-1,CHBLK,21)", "80", "O", "DISPLAYBASE", "17010"  
"boywtw", "catwmm17|COLOUR1,3|", "SY(BOYLAT55);TX(OBJNAM,2,1,2,'14106',-1,-1,CHBLK,21)", "80", "O", "DISPLAYBASE", "17010"  
"boywtw", "catwmm17|COLOUR3,1|", "SY(BOYLAT55);TX(OBJNAM,2,1,2,'14106',-1,-1,CHBLK,21)", "80", "O", "DISPLAYBASE", "17010"  
"boywtw", "catwmm17|COLOUR3,4,3|", "SY(BOYLAT52);TX(OBJNAM,2,1,2,'14106',-1,-1,CHBLK,21)", "80", "O", "DISPLAYBASE", "17010"  
"boywtw", "catwmm18|COLOUR1,4|", "SY(BOYLAT56);TX(OBJNAM,2,1,2,'14106',-1,-1,CHBLK,21)", "80", "O", "DISPLAYBASE", "17010"  
"boywtw", "catwmm18|COLOUR4,1|", "SY(BOYLAT56);TX(OBJNAM,2,1,2,'14106',-1,-1,CHBLK,21)", "80", "O", "DISPLAYBASE", "17010"  
"boywtw", "catwmm18|COLOUR4,3,4|", "SY(BOYLAT53);TX(OBJNAM,2,1,2,'14106',-1,-1,CHBLK,21)", "80", "O", "DISPLAYBASE", "17010"  
"boywtw", "catwmm19|COLOUR6|", "SY(boyspp50);TX(OBJNAM,2,1,2,'14106',-1,-1,CHBLK,21)", "80", "O", "DISPLAYBASE", "17010"  
"boywtw", "COLOUR6|", "SY(boyspp50);TX(OBJNAM,2,1,2,'14106',-1,-1,CHBLK,21)", "80", "O", "DISPLAYBASE", "17010"  
"bridge", "", "SY(BRIDGE01)", "80", "O", "DISPLAYBASE", "12210"  
"bunsta", "", "SY(CHINFO07)", "80", "O", "STANDARD", "22410"  
"bunsta", "catbun1|", "SY(BUNSTA01)", "80", "O", "STANDARD", "22410"  
"bunsta", "catbun2|", "SY(BUNSTA02)", "80", "O", "STANDARD", "22410"

"bunsta","catbun3|","SY(BUNSTA03)","80","O","STANDARD","22410"  
"dismar","catdis5|","SY(HECMTR02);TX(INFORM,3,1,2,'14106',1,0,CHMGD,21)","60","O","STANDARD","22430"  
"dismar","catdis6|","SY(HECMTR01);TX(INFORM,3,1,2,'14106',1,0,CHMGD,21)","60","O","STANDARD","22430"  
"dismar","catdis7|","SY(DISMAR06);TX(INFORM,3,1,2,'14106',1,-1,CHBLK,21)","60","O","OTHER","31050"  
"dismar","catdis8|","SY(DISMAR05)","60","O","OTHER","31050"  
"hrbfac","","SY(HRBFAC10)","70","O","STANDARD","22410"  
"hrbfac","cathaf6|","SY(HRBFAC11)","70","O","STANDARD","22410"  
"hrbfac","cathaf9|","SY(HRBFAC12)","70","O","STANDARD","22410"  
"hrbfac","cathaf12|","SY(HRBFAC13)","70","O","STANDARD","22410"  
"hrbfac","cathaf13|","SY(HRBFAC14)","70","O","STANDARD","22410"  
"hrbfac","cathaf14|","SY(HRBFAC15)","70","O","STANDARD","22410"  
"hrbfac","cathaf15|","SY(HRBFAC16)","70","O","STANDARD","22410"  
"hrbfac","cathaf16|","SY(HRBFAC17)","70","O","STANDARD","22410"  
"hrbfac","cathaf17|","SY(HRBFAC18)","70","O","STANDARD","22410"  
"notmrk","","SY(NOTMRK02)","80","O","DISPLAYBASE","17030"  
"notmrk","catnmk1|","SY(NMKPRH02,ORIENT)","80","O","DISPLAYBASE","17030"  
"notmrk","catnmk12|","SY(NMKPRH12,ORIENT)","80","O","DISPLAYBASE","17030"  
"notmrk","catnmk13|","SY(NMKPRH13,ORIENT)","80","O","DISPLAYBASE","17030"  
"notmrk","catnmk44|","SY(NMKRCD01,ORIENT)","80","O","DISPLAYBASE","17030"  
"notmrk","catnmk45|","SY(NMKRCD02,ORIENT)","80","O","DISPLAYBASE","17030"  
"notmrk","catnmk46|","SY(NMKRCD03,ORIENT)","80","O","DISPLAYBASE","17030"  
"notmrk","catnmk47|","SY(NMKRCD04,ORIENT)","80","O","DISPLAYBASE","17030"  
"notmrk","catnmk50|","SY(NMKINF01,ORIENT)","80","O","DISPLAYBASE","17030"  
"notmrk","fnctnm1|","SY(NOTMRK01)","80","O","DISPLAYBASE","17030"  
"notmrk","fnctnm4|","SY(NOTMRK03)","80","O","DISPLAYBASE","17030"  
"notmrk","fnctnm5|","SY(NOTMRK03)","80","O","DISPLAYBASE","17030"  
"rdocal","","SY(RCLDEF01)","60","O","DISPLAYBASE","15060"  
"rdocal","TRAFIC1|","SY(rdocal02,ORIENT);TX(COMCHA,1,2,2,'14106',0,0,CHMGD,11);TX(OBJNAM,3,2,2,'14106',2,-2,CHBLK,11)","60","O","DISPLAYBASE","15060"  
"rdocal","TRAFIC2|","SY(rdocal02,ORIENT);TX(COMCHA,1,2,2,'14106',0,0,CHMGD,11);TX(OBJNAM,3,2,2,'14106',2,-2,CHBLK,11)","60","O","DISPLAYBASE","15060"  
"rdocal","TRAFIC3|","SY(rdocal02,ORIENT);TX(COMCHA,1,2,2,'14106',0,0,CHMGD,11);TX(OBJNAM,3,2,2,'14106',2,-2,CHBLK,11)","60","O","DISPLAYBASE","15060"  
"rdocal","TRAFIC4|","SY(rdocal03,ORIENT);TX(COMCHA,1,2,2,'14106',0,0,CHMGD,11);TX(OBJNAM,3,2,2,'14106',2,-2,CHBLK,11)","60","O","DISPLAYBASE","15060"  
"refdmp","","SY(REFDMP01)","80","O","STANDARD","22410"  
"rtplpt","","",""  
"sistat","","SY(SISTAT02)","70","O","STANDARD","28020"  
"sistat","catsit2|","SY(SSENTR01)","70","O","STANDARD","28020"  
"sistat","catsit6|","SY(SSLOCK01)","70","O","STANDARD","28020"  
"sistat","catsit10|","SY(SSWARS01)","70","O","STANDARD","28020"  
"sistaw","","SY(SISTAT02)","70","O","STANDARD","28020"  
"sistaw","catsiw12|","SY(WTLVGG02)","70","O","STANDARD","28020"  
"sistaw","catsiw13|","SY(WTLVGG01)","70","O","STANDARD","28020"  
"sistaw","catsiw15|","SY(HGWTMK01)","70","O","STANDARD","28020"  
"sistaw","catsiw16|","SY(VTCLMK01)","70","O","STANDARD","28020"  
"sistaw","catsiw17|","SY(VTCLMK01);SY(WTLVGG02)","70","O","STANDARD","28020"  
"termnl","","SY(TERMNL12)","80","O","STANDARD","22420"  
"termnl","cattml1|","SY(TERMNL01)","80","O","STANDARD","22420"  
"termnl","cattml1|","SY(TERMNL03)","80","O","STANDARD","22420"  
"termnl","cattml3|","SY(TERMNL12)","80","O","STANDARD","22420"  
"termnl","cattml3|trshgd1|","SY(TERMNL03)","80","O","STANDARD","22420"  
"termnl","cattml3|trshgd2|","SY(TERMNL04)","80","O","STANDARD","22420"  
"termnl","cattml3|trshgd3|","SY(TERMNL05)","80","O","STANDARD","22420"  
"termnl","cattml3|trshgd4|","SY(TERMNL06)","80","O","STANDARD","22420"  
"termnl","cattml3|trshgd5|","SY(TERMNL07)","80","O","STANDARD","22420"  
"termnl","cattml3|trshgd6|","SY(TERMNL08)","80","O","STANDARD","22420"



"termnl","cattml3|trshgd7|","SY(TERMNL09)","80","O","STANDARD","22420"  
"termnl","cattml3|trshgd8|","SY(TERMNL10)","80","O","STANDARD","22420"  
"termnl","cattml3|trshgd9|","SY(TERMNL11)","80","O","STANDARD","22420"  
"termnl","cattml3|trshgd10|","SY(TERMNL12)","80","O","STANDARD","22420"  
"topmar","","CS(TOPMARI1)","80","O","DISPLAYBASE","17010"  
"trnbsn","","SY(TRNBSN01)","60","O","STANDARD","26020"

## Lines

"berths","","LS(SOLD,3,CHGRD);SY(BRTHNO01);TX(OBJNAM,1,2,3,'14108',1,0,CHMGD,29)","50","O","OTHER","32440"  
"bridge","","LS(SOLD,4,CHGRD);TX(OBJNAM,3,1,2,'24207',1,0,CHBLK,21);TE('clr  
%4.1lf','VERCLR',3,1,2,'24207',1,1,CHBLK,52)","60","O","DISPLAYBASE","12210"  
"bridge","CATBRG2|","LS(SOLD,4,CHGRD);SY(bridge01);TE('clr cl %4.1lf','VERCCL',3,1,2,'24207',1,0,CHBLK,52);TE('clr op  
%4.1lf','VERCOP',3,1,2,'24207',1,1,CHBLK,52)","60","O","DISPLAYBASE","12210"  
"bridge","CATBRG3|","LS(SOLD,4,CHGRD);SY(bridge01);TE('clr cl %4.1lf','VERCCL',3,1,2,'24207',1,0,CHBLK,52);TE('clr op  
%4.1lf','VERCOP',3,1,2,'24207',1,1,CHBLK,52)","60","O","DISPLAYBASE","12210"  
"bridge","CATBRG4|","LS(SOLD,4,CHGRD);SY(bridge01);TE('clr cl %4.1lf','VERCCL',3,1,2,'24207',1,0,CHBLK,52);TE('clr op  
%4.1lf','VERCOP',3,1,2,'24207',1,1,CHBLK,52)","60","O","DISPLAYBASE","12210"  
"bridge","CATBRG5|","LS(SOLD,4,CHGRD);SY(bridge01);TE('clr cl %4.1lf','VERCCL',3,1,2,'24207',1,0,CHBLK,52);TE('clr op  
%4.1lf','VERCOP',3,1,2,'24207',1,1,CHBLK,52)","60","O","DISPLAYBASE","12210"  
"bridge","CATBRG7|","LS(SOLD,4,CHGRD);SY(bridge01);TE('clr cl  
%4.1lf','VERCCL',3,1,2,'24207',1,0,CHBLK,52);TE('clr op  
%4.1lf','VERCOP',3,1,2,'24207',1,1,CHBLK,52)","60","O","DISPLAYBASE","12210"  
"bridge","CATBRG8|","LS(SOLD,4,CHGRD);SY(bridge01);TE('clr cl %4.1lf','VERCCL',3,1,2,'24207',1,0,CHBLK,52);TE('clr op  
%4.1lf','VERCOP',3,1,2,'24207',1,1,CHBLK,52)","60","O","DISPLAYBASE","12210"  
"canbnk","","LS(SOLD,1,CSTLN)","50","O","DISPLAYBASE","12410"  
"cblohd","","LS(DASH,2,CHGRD)","60","O","DISPLAYBASE","12210"  
"cblohd","CONRAD1|VERCSA|","LS(DASH,2,CHGRD);SY(RACNSP01);TE('sf clr  
%4.1lf','VERCSA',3,1,2,'24207',1,0,CHBLK,52)","60","O","DISPLAYBASE","12210"  
"cblohd","CONRAD3|VERCSA|","LS(DASH,2,CHGRD);SY(RACNSP01);TE('sf clr  
%4.1lf','VERCSA',3,1,2,'24207',1,0,CHBLK,52)","60","O","DISPLAYBASE","12210"  
"cblohd","CONRAD1|VERCLR|","LS(DASH,2,CHGRD);SY(RACNSP01);TE('clr  
%4.1lf','VERCLR',3,1,2,'24207',1,0,CHBLK,52)","60","O","DISPLAYBASE","12210"  
"cblohd","CONRAD3|VERCLR|","LS(DASH,2,CHGRD);SY(RACNSP01);TE('clr  
%4.1lf','VERCLR',3,1,2,'24207',1,0,CHBLK,52)","60","O","DISPLAYBASE","12210"  
"cblohd","CONRAD1|","LS(DASH,2,CHGRD);SY(RACNSP01)","60","O","DISPLAYBASE","12210"  
"cblohd","CONRAD3|","LS(DASH,2,CHGRD);SY(RACNSP01)","60","O","DISPLAYBASE","12210"  
"cblohd","VERCSA|","LS(DASH,2,CHGRD);TE('sf clr %4.1lf','VERCSA',3,1,2,'24207',1,0,CHBLK,52)","60","O","DISPLAYBASE","12210"  
"cblohd","VERCLR|","LS(DASH,2,CHGRD);TE('sf clr %4.1lf','VERCLR',3,1,2,'24207',1,0,CHBLK,52)","60","O","DISPLAYBASE","12210"  
"feryrt","","LC(FERYRT02)","40","O","STANDARD","25030"  
"feryrt","CATFRY1|","LC(FERYRT01)","40","O","STANDARD","25030"  
"feryrt","CATFRY2|","LC(FERYRT02)","40","O","STANDARD","25030"  
"rdocal","","LS(DASH,1,TRFCD);SY(RCLDEF01);TX(OBJNAM,3,2,2,'24207',1,-1,CHBLK,21)","60","O","DISPLAYBASE","15060"  
"rdocal","TRAFIC1|ORIENT|","LS(DASH,1,TRFCD);SY(rdocal02,ORIENT);TX(OBJNAM,3,1,2,'24207',1,-  
1,CHBLK,21);TX(COMCHA,3,1,2,'24207',1,1,CHBLK,52)","60","O","DISPLAYBASE","15060"  
"rdocal","TRAFIC2|ORIENT|","LS(DASH,1,TRFCD);SY(rdocal02,ORIENT);TX(OBJNAM,3,1,2,'24207',1,-  
1,CHBLK,21);TX(COMCHA,3,1,2,'24207',1,1,CHBLK,52)","60","O","DISPLAYBASE","15060"  
"rdocal","TRAFIC3|ORIENT|","LS(DASH,1,TRFCD);SY(rdocal02,ORIENT);TX(OBJNAM,3,1,2,'24207',1,-  
1,CHBLK,21);TX(COMCHA,3,1,2,'24207',1,1,CHBLK,52)","60","O","DISPLAYBASE","15060"  
"rdocal","TRAFIC4|ORIENT|","LS(DASH,1,TRFCD);SY(rdocal03,ORIENT);TX(OBJNAM,3,1,2,'24207',1,-  
1,CHBLK,21);TX(COMCHA,3,1,2,'24207',1,1,CHBLK,52)","60","O","DISPLAYBASE","15060"  
"rivbnk","","LS(SOLD,1,CSTLN)","50","O","DISPLAYBASE","12410"  
"rivbnk","catbnk3|","LS(SOLD,2,CSTLN)","50","O","DISPLAYBASE","12410"  
"rivbnk","NATSUR6|","LS(DOTT,2,CSTLN)","50","O","DISPLAYBASE","12410"  
"rivbnk","NATSUR9|","LS(DOTT,2,CSTLN)","50","O","DISPLAYBASE","12410"  
"wtwaxs","","LS(DOTT,1,CHGRD)","30","S","OTHER","31010"  
"wtwprf","","LS(DOTT,1,CHGRD)","30","S","OTHER","31010"

## Areas

"achare", "", "SY(ACHARE51);LS(DASH,2,CHMGF);CS(RESTRN01)", "20", "S", "STANDARD", "26220"  
"achbrt", "", "SY(ACHBRT07);TX(OBJNAM,3,1,2,'14106',1,0,CHBLK,29);LS(DASH,2,CHMGF)", "20", "S", "STANDARD", "26220"  
"berths", "", "SY(BRTHNO01);TX(OBJNAM,1,2,3,'14108',0,0,CHMGD,29);LS(DASH,2,CHMGF)", "30", "S", "STANDARD", "22440"  
"bridge", "", "AC(CHBRN,1);TE('clr cl %4.1lf','VERCCL',3,1,2,'14108',1,0,CHBLK,11);TE('clr op %4.1lf','VERCOP',3,1,2,'14108',1,1,CHBLK,11);LS(SOLD,2,CHGRD)", "50", "O", "DISPLAYBASE", "12210"  
"brgare", "", "", "", "", "", ""  
"comare", "", "", "", "", "", ""  
"depare", "", "CS(DEPARE01)", "10", "S", "DISPLAYBASE", "13030"  
"feryrt", "", "SY(FRYARE51);LC(NAVARE51)", "40", "S", "STANDARD", "26040"  
"feryrt", "CATFRY2", "SY(FRYARE52);LC(NAVARE51)", "40", "S", "STANDARD", "26040"  
"hrbare", "", "TX(OBJNAM,1,2,3,'15106',0,0,CHBLK,28);LS(DASH,1,CHGRD)", "20", "S", "OTHER", "36020"  
"hrbare", "cathbr3", "SY(SMCFAC02);TX(OBJNAM,1,2,3,'15106',0,3,CHBLK,28);LS(DASH,1,CHGRD)", "20", "S", "OTHER", "36020"  
"hrbsbn", "", "LS(DASH,1,CHGRF)", "20", "S", "DISPLAYBASE", "12420"  
"hrbfac", "", "AC(CHBRN,3);SY(HRBFAC10)", "40", "O", "STANDARD", "22410"  
"hrbfac", "cathaf6", "AC(CHBRN,3);SY(HRBFAC11)", "40", "O", "STANDARD", "22410"  
"hrbfac", "cathaf9", "AC(CHBRN,3);SY(HRBFAC12)", "40", "O", "STANDARD", "22410"  
"hrbfac", "cathaf12", "AC(CHBRN,3);SY(HRBFAC13)", "40", "O", "STANDARD", "22410"  
"hrbfac", "cathaf13", "AC(CHBRN,3);SY(HRBFAC14)", "40", "O", "STANDARD", "22410"  
"hrbfac", "cathaf14", "AC(CHBRN,3);SY(HRBFAC15)", "40", "O", "STANDARD", "22410"  
"hrbfac", "cathaf15", "AC(CHBRN,3);SY(HRBFAC16)", "40", "O", "STANDARD", "22410"  
"hrbfac", "cathaf16", "AC(CHBRN,3);SY(HRBFAC17)", "40", "O", "STANDARD", "22410"  
"hrbfac", "cathaf17", "AC(CHBRN,3);SY(HRBFAC18)", "40", "O", "STANDARD", "22410"  
"lokare", "", "", "", "", "", ""  
"lokbsn", "", "LS(DASH,2,CHGRF)", "20", "S", "DISPLAYBASE", "12420"  
"lkspt", "", "LS(DASH,2,CHGRF)", "20", "S", "DISPLAYBASE", "12420"  
"m\_nsys", "", "", "", "", "", ""  
"prtare", "", "", "", "", "", ""  
"resare", "", "LS(DASH,2,CHMGD);CS(RESARE1)", "30", "S", "STANDARD", "26010"  
"termnl", "", "AC(CHGRF,3);SY(TERMNL12)", "40", "O", "STANDARD", "22420"  
"termnl", "cattml1", "AC(CHGRF,3);SY(TERMNL01)", "40", "O", "STANDARD", "22420"  
"termnl", "cattml2", "AC(CHGRF,3);SY(TERMNL02)", "40", "O", "STANDARD", "22420"  
"termnl", "cattml3", "AC(CHGRF,3);SY(TERMNL12)", "40", "O", "STANDARD", "22420"  
"termnl", "cattml3|trshgd1", "AC(CHGRF,3);SY(TERMNL03)", "40", "O", "STANDARD", "22420"  
"termnl", "cattml3|trshgd2", "AC(CHGRF,3);SY(TERMNL04)", "40", "O", "STANDARD", "22420"  
"termnl", "cattml3|trshgd3", "AC(CHGRF,3);SY(TERMNL05)", "40", "O", "STANDARD", "22420"  
"termnl", "cattml3|trshgd4", "AC(CHGRF,3);SY(TERMNL06)", "40", "O", "STANDARD", "22420"  
"termnl", "cattml3|trshgd5", "AC(CHGRF,3);SY(TERMNL07)", "40", "O", "STANDARD", "22420"  
"termnl", "cattml3|trshgd6", "AC(CHGRF,3);SY(TERMNL08)", "40", "O", "STANDARD", "22420"  
"termnl", "cattml3|trshgd7", "AC(CHGRF,3);SY(TERMNL09)", "40", "O", "STANDARD", "22420"  
"termnl", "cattml3|trshgd8", "AC(CHGRF,3);SY(TERMNL10)", "40", "O", "STANDARD", "22420"  
"termnl", "cattml3|trshgd9", "AC(CHGRF,3);SY(TERMNL11)", "40", "O", "STANDARD", "22420"  
"termnl", "cattml3|trshgd10", "AC(CHGRF,3);SY(TERMNL12)", "40", "O", "STANDARD", "22420"  
"trnbsn", "", "SY(TRNBSN01);LS(DASH,2,CHMGD)", "30", "O", "STANDARD", "26020"

### **3.2 Extended entries for S-57 object classes**

#### **3.2.1 Areas**

"BUAARE","CATBUA5","AC(CHBRN);TX(OBJNAM,1,2,3,'15106',0,0,CHBLK,26);LS(SOLD,1,LANDF),"30","S","STANDARD","22240"  
"SLCONS","CATSLC4","SY(PIER0001),"60","O","DISPLAYBASE","12410"

## **4 Extensions of conditional symbology procedures (CS)**

### **4.1 Top marks**

The symbolization of top marks depends on whether the top mark is located on a floating object (buoy) or on a fixed object (beacon). This is checked by the CS (TOPMAR01). In inland water navigation, the colour and top mark shape of beacons are more important than for maritime navigation. Therefore, top marks of beacons shall be symbolized in their real shape and colour, and a new CS (TOPMAR|1) for top marks must be applied by copying and extending the existing CS (see annex to this presentation library).

### **4.2 Restricted areas**

The CS (RESARE02) for the RESARE object class is affected because in this CS the values of the attribute RESTRN are checked. In Inland ECDIS, the object class RESARE and the attribute RESTRN are copied. Therefore, the CS (RESARE02) has also to be copied as CS (RESAR|1) and extended by "resare" and "restrn".

### **4.3 Lights**

The CS for the LIGHTS object class is affected because in this CS there is a check whether a light is located on a floating object or on a fixed object. The list of floating platforms must be extended by the new object class "boywtw". To avoid a copy of this CS which would lead to a copy of the official object class LIGHTS, the Inland ECDIS manufacturers have to extend the official CS for LIGHTS as described above.

### **4.4 Notice marks**

For the symbolization of the notice marks in the "information window on notice marks" (see 6), the main notice mark must be combined with the auxiliary panel. Therefore, a new CS for notice marks has to be applied.

## 5 Extensions to the Symbol Library

New symbols are designed as bitmap (BMP) files with a pixel program. The BMP files are converted into the specific S-57 raster format. Vector symbols are designed with a special symbol editor.

### 5.1 New symbols to be shown on the chart display (simplified point symbols)

#### 5.1.1 Raster symbols

##### a. Symbols in general

bunsta01:	bunker station, diesel oil station
bunsta02:	bunker station, water
bunsta03:	bunker station, ballast
dismar05:	distance mark 100m on river axis
dismar06:	distance mark 1km on river axis
hecctr01:	hectometre point, 100m
hecctr02:	hectometre point, 1km
hgwtrk01:	high water mark
notmrk01:	notice mark, prohibition
notmrk02:	notice mark, regulation, restriction
notmrk03:	notice mark, information, recommendation
radhlt01:	radar highlight (CONRAD=1)
refdmp01:	refuse dump
ssentr01:	port entry
sslock01:	signal station, lock
sswars01:	signal station, wahrschau
trnbsn01:	turning basin
vtclmk01:	vertical clearance mark at bridges
wtlvgg01:	gauge, height of water
wtlvgg02:	recording gauge, height of water

##### b. Navigational aids

bcnlat50:	beacon stake - pole
boylat50:	river buoy fairway, red, right side
boylat51:	river buoy fairway, green, left side
boylat52:	river buoy fairway junction, turn off, red-green-red, right side
boylat53:	river buoy fairway junction, turn off, green-red-green, left side
boylat54:	river buoy fairway splitting, red-green....
boylat55:	river buoy obstruction red-white, right side
boylat56:	river buoy obstruction green-white, left side
boyspp50:	buoy special purpose
topma100:	beacon top mark, red cone, point down
topma101:	beacon top mark, red boarded cone, point down
topma102:	beacon top mark, green cone, point up
topma103:	beacon top mark, green boarded cone, point up
topma104:	beacon top mark, red boarded cone, point down, green boarded cone, point up, simplified
topma105:	beacon top mark, red boarded cone, point down, green boarded cone, point up, simplified
topma106:	beacon top mark, white-red square board, vertical
topma107:	beacon top mark, red boarded square board, vertical
topma108:	beacon top mark, white-green square board, diagonal
topma109:	beacon top mark, green boarded square board, diagonal
topma110:	beacon top mark, yellow-black square board, vertical
topma111:	beacon top mark, yellow St.Georg cross
topma112:	beacon top mark, yellow-black square board, diagonal
topma113:	beacon top mark, yellow Andreacross
topma114:	buoy top mark, red cylinder
topma115:	buoy top mark, green cone, point up
topma116:	buoy top mark, red-white-red board, entry prohibited

### **c. Harbour facilities and terminals**

hrbfac10:	default harbour facility
hrbfac11:	harbour facility naval base
hrbfac12:	harbour facility ship yard
hrbfac13:	harbour facility harbour-master's office
hrbfac14:	harbour facility pilot
hrbfac15:	harbour facility water police
hrbfac16:	harbour facility customs office
hrbfac17:	harbour facility service and repair
hrbfac18:	harbour facility quarantine station
termnl01:	terminal, passenger terminal
termnl02:	terminal, ferry terminal
termnl03:	terminal, Container transshipment
termnl04:	terminal, Bulk transshipment
termnl05:	terminal, Oil transshipment
termnl06:	terminal, Fuel transshipment
termnl07:	terminal, Chemical transshipment
termnl08:	terminal, Liquid Goods transshipment
termnl09:	terminal, Explosive goods transshipment
termnl10:	terminal, Fish transshipment
termnl11:	terminal, Car transshipment
termnl12:	terminal, General Cargo transshipment
termnl13:	terminal, RoRo Terminal

### **5.1.2 Vector symbols (must be rotated, the numbers refer to CEVNI)**

- nmkprh02: entry prohibited (A.1)
- nmkprh12: passing on the left side prohibited (A.10)
- nmkprh13: passing on the right side prohibited (A.10)
- nmkrcd01: recommended passage for both directions (D.1a)
- nmkrcd02: recommended passage for only one direction (D.1b)
- nmkrcd03: recommended passage on the right side (D.2)
- nmkrcd04: recommended passage on the left side (D.2)
- nmkinf01: entry permitted (E.1)

### **5.2 New symbols to be shown in the "information window on notice marks"**

#### **a. notice marks (the numbers refer to CEVNI)**

- nmkprh01: entry prohibited (A.1)
- nmkprh03: closed area, but small craft boats without engine permitted (A.1.a, only RheinSchPV and Binnenvaartpolitiereglement)
- nmkprh04: overtaking prohibited (A.2)
- nmkprh05: overtaking between push tows and towing units prohibited (A.3)
- nmkprh06: no passing and overtaking (A.4)
- nmkprh07: berthing prohibited (A.5)
- nmkprh08: anchoring prohibited (A.6)
- nmkprh09: making fast to the bank prohibited (A.7)
- nmkprh10: turning prohibited (A.8)
- nmkprh11: avoid wave wash (A.9)
- nmkprh14: boats with engine prohibited (A.12)
- nmkprh15: sport and pleasure boats prohibited (A.13)
- nmkprh16: waterskiing prohibited (A.14)
- nmkprh17: sailing boats prohibited (A.15)
- nmkprh18: boats without engines or sails prohibited (A.16)
- nmkprh19: windsurfing prohibited (A.17)
- nmkprh20: waterscooters and jetskis prohibited (A.18)
- nmkprh21: high speed boats prohibited (A.18)

- nmkprh22: slipping of boats prohibited (A.19)
- nmkreg01: general restrictions (with additional sign) (C.4)
- nmkreg02: mandatory traffic direction, left (B.1)
- nmkreg03: mandatory traffic direction, right (B.1)
- nmkreg04: mandatory change of the fairway side to port (B.2a)
- nmkreg05: mandatory change of the fairway side to starboard (B.2b)
- nmkreg06: port fairwayside is mandatory traffic direction (B.3a)
- nmkreg07: starboard fairwayside is mandatory traffic direction (B.3b)
- nmkreg08: mandatory crossing of the fairway side to port (B.4a)
- nmkreg09: mandatory crossing of the fairway side to starboard (B.4b)
- nmkreg10: mandatory stop (B.5)
- nmkreg11: mandatory sound signal (B.7)
- nmkreg12: special attention (B.8)
- nmkreg13: give way other vessels when entering the main fairway (B.9a)
- nmkreg14: give way other vessels when crossing the main fairway (B.9b)
- nmkreg15: mandatory radiophone (B.11)
- nmkreg16: restricted fairway depth (C.1)
- nmkreg17: restricted vertical clearance (C.2)
- nmkreg18: restricted width of the fairway (C.3)
- nmkreg19: restricted width of the waterway at the left bank (C.5)
- nmkreg20: restricted width of the waterway at the right bank (C.5)
- nmkrcd05: recommended traffic direction, left (D.3)
- nmkrcd06: recommended traffic direction, right (D.3)
- nmkinf02: overhead power line crossing (E.2)
- nmkinf03: weir (E.3)
- nmkinf04: cable ferry (E.4)
- nmkinf05: ferry (E.4b)
- nmkinf06: berthing permitted (E.5)
- nmkinf07: berthing facilities for push tows (E.5.4)
- nmkinf08: berthing facilities for push with one blue cone (E.5.5)
- nmkinf09: berthing facilities for push tows with two blue cones (E.5.6)
- nmkinf10: berthing facilities for push tows with three blue cones (E.5.7)
- nmkinf11: berthing facilities for other than push tows (E.5.8)
- nmkinf12: berthing facilities for other than push tows one blue cone (E.5.9)
- nmkinf13: berthing facilities for other than push tows with two blue cones (E.5.10)
- nmkinf14: berthing facilities for other vessels than push tows three blue cones (E.5.11)
- nmkinf15: berthing facilities for all vessels (E.5.12)
- nmkinf16: berthing facilities for all vessels with one blue cone (E.5.13)
- nmkinf17: berthing facilities for all vessels with two blue cones (E.5.14)
- nmkinf18: berthing facilities for all vessels with three blue cones (E.5.15)
- nmkinf19: anchoring permitted (E.6)
- nmkinf20: making fast to the bank permitted (E.7)
- nmkinf21: facilities for making fast to the bank of vehicles (E.7.1)
- nmkinf22: turning permitted (E.8)
- nmkinf23: crossing with secondary waterway ahead (E.9a)
- nmkinf24: secondary fairway ahead on the right (E.9.b)
- nmkinf25: secondary fairway ahead on the left (E.9.c)
- nmkinf26: secondary fairway ahead (main fairway right)
- nmkinf27: secondary fairway ahead (main fairway left)
- nmkinf28: secondary fairway left (main fairway right)
- nmkinf29: secondary fairway right (main fairway left)
- nmkinf30: secondary fairway ahead and left (main fairway right)
- nmkinf31: secondary fairway ahead and right (main fairway left)
- nmkinf32: crossing with main fairway ahead (E.10.a)
- nmkinf33: junction with main fairway ahead (E.10.b)
- nmkinf34: junction with main fairway ahead and right
- nmkinf35: junction with main fairway ahead and left
- nmkinf36: junction with main fairway ahead and right (secondary fairway left)
- nmkinf37: junction with main fairway ahead and left (secondary fairway right)
- nmkinf38: end of prohibition or regulation (E.11)

- nmkinf39: drink water (E.13)
- nmkinf40: telephone (E.14)
- nmkinf41: boats with engine permitted (E.15)
- nmkinf42: sport and pleasure boats permitted (E.16)
- nmkinf43: waterski (E.17)
- nmkinf44: sailing boats (E.18)
- nmkinf45: boats without engine or sails (E.19)
- nmkinf46: windsurfing (E.20)
- nmkinf47: nautical radio information (E.21)
- nmkinf48: waterscooters, jetskis (E.22)
- nmkinf49: high speed boats permitted (E.21)
- nmkinf50: facilities for berthing of vehicles (E.22)
- nmkinf51-55: maximum number of vessels mooring side by side (E.5.3)

#### **b. Auxiliary panels (CEVNI Annex 7, Section II)**

- addmrk01: top (board)
- addmrk02: bottom (board)
- addmrk03: right (triangle to the right)
- addmrk04: left (triangle to the left)
- addmrk05: top (board, square main board)
- addmrk06: bottom (board, square main board)
- addmrk07: right (triangle to the right, landscape main board)
- addmrk08: left (triangle to the left, landscape main board)

## **6 Presentation of notice marks**

Notice marks which are located at the river bank are presented twice:

1. In the chart presentation notice marks are displayed by generic symbols (notmrk01, notmrk02 and notmrk03). This does not apply to the notice marks on bridges.
2. To display the detailed symbol of a notice mark which is similar to the real world indication the user must pick on the generic symbol in the chart. Then, the special "information window on notice" marks pop up showing the detailed notice mark symbol and offering the full set of object information. This does not apply to the notice marks on bridges.

Notice marks which are located at bridges (see no 5.1.2 and 8.2 vector symbols), shall be symbolized according to the orientation of the bridge.

Notice marks which specify distances or a velocity will not be symbolized with the number itself, but only with that symbol which gives the general regulation or information.

## **7 Presentation of objects for radar map matching**

The presentation of objects necessary for radar map matching is handled by the application. This is not done by means of look-up tables. A kernel function is available which extracts those objects and presents them in the required way. The object classes for radar map matching are listed in section 2, appendix B, annex A (Use of the Object Catalogue for Inland ECDIS), ch. 12.12. For the symbolization of the point objects for radar map matching see ch. 5.1.1.g and ch. 8.1, picture RADHLT01 of this presentation library.





8.1.2 Navigational aids

NODTAR			
OCURSR	BCNLAT50	BOYLAT50	BOYLAT51
CHBELK			
CHGRD	BOYLAT52	BOYLAT53	BOYLAT54
CHGRF			
CHRED	BOYLAT55	BOYLAT56	BOYSPP50
CHGRN			
CHYLW	TOPMA100	TOPMA101	TOPMA102
CHMGD			
CHMGF	TOPMA103	TOPMA104	TOPMA105
CHERN			
CHWHT	TOPMA106	TOPMA107	TOPMA108
SCLEBR			
CHCOR	TOPMA109	TOPMA110	TOPMA111
LITRD			
LITGN	TOPMA112	TOPMA113	TOPMA114
LITTYW			
ISDNG	TOPMA115	TOPMA116	
DNGHL			
TRFCDF			
TRFCF			
LANDA			
LANDF			
CSTLN			
SNDG1			
SNDG2			
SNDG3			
DEPSC			
DEPCN			
DEPDW			
DEPMD			
DEPMS			
DEPVV			
DEPPI			
RADHI			
RADLO			
ARPAT			
NINFO			
RESBL			
ADINF			
RESGR			
SHIPR			
PSYTRK			
SPLRT			
APLRT			
UIBCK			
UIBDR			
UIAFD			
UIAFD			
UIINF			
UIINF			
UIINF			
UIINF			
UIINF			
UIINF			
UIINF			
OUTLW			
OUTLL			
RESS01			
RESS02			
RESS03			
RESS04			
RESS05			

### 8.1.3 Harbour facilities, terminals









NODTAR		
CURSELK	HRBFAC10	HRBFAC11
CHGRD		
CHGRFD	HRBFAC12	HRBFAC13
CHGRN		
CHYLW	HRBFAC14	HRBFAC15
CHMGD		
CHMCF	HRBFAC16	HRBFAC17
CHERN		
CHWHT	HRBFAC18	TERMNLO1
SCLEBR		
CHCOR	TERMNLO2	TERMNLO3
LITRD		oil
LITGN	TERMNLO4	TERMNLO5
LITYW	fuel	che
ISDN	TERMNLO6	TERMNLO7
DNGHL	liq	
TRFCDF	TERMNLO8	TERMNLO9
TRFCF		
LANDA	TERMNLO10	TERMNLO11
LANDFN		RoRo
CSSTLN	TERMNLO12	TERMNLO13
SNDGCL		
SNDCC		
DEPSCN		
DEPCW		
DEPDW		
DEPMD		
DEPM		
DEPV		
DEPI		
RADHI		
RADLO		
ARPAT		
NINF		
RESBL		
ADINF		
RESGR		
SHIP		
SYTRK		
PLPTE		
APLRT		
UIBCK		
UIBDR		
UIAFD		
UIAFF		
UINF		
UINF		
UINF		
UINF		
UINF		
UINF		
UINF		
OUTLW		
OUTLL		
RESS01		
RESS02		
RESS03		
RESS04		
RESS05		













NODTAR		
CURSR		
CHBLK		
CHGRD		
CHGRF		
CHRED		ADDMRK01
CHGRN		
CHYLW		
CHMGD		
CHMGF		
CHERN		
CHWHT		ADDMRK02
SCLEBR		
CHCOR		
LITRD		
LITGN		ADDMRK03
LITYW		
ISDMG		
DNGHL		
TRFCB		
TRFCF		
LANDA		
LANDF		
CSTLN		
SNDG1		ADDMRK04
SNDG2		
DEPCN		
DEPCW		
DEPMD		
DEPMS		ADDMRK05
DEPVV		
DEPIT		
RADHI		
RADLO		
ARPAT		
NINF0		ADDMRK06
RESBL		
ADINF		
RESGR		
SHLPK		
PSYTRK		
PLRTE		ADDMRK07
APLRT		
UIBCK		
UIBDP		
UIAFD		
UIAFF		
UINF0		ADDMRK08
UINF1		
UINF2		
UINF3		
UINF4		
UINF5		
UINF6		
UINF7		
UINF8		
UINF9		
OUTLW		
OUTLL		
RESS01		
RESS02		
RESS03		
RESS04		
RESS05		

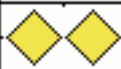
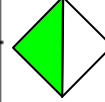

### 8.3 Vector symbols

NODTA	
CURSR	
CHBLK	
CHCRD	
CHGRF	
CHRED	
CHCRM	NMKINF01
CHYLW	
CHMGD	
CHMGF	
CHERN	
CHWHT	
SCLEBR	NMKPRH02
CHCOR	
LITTRD	
LITTCM	
LITYW	
LISDNG	
DNGHL	
TRFCDF	NMKPRH12
TRFCDF	
LANDA	
LANDF	
CCSTLN	
SSNDG1	
SSNDG2	NMKPRH13
DEPSCC	
DEPCCN	
DEPDW	
DEPMD	
DEPMSS	
DEPPVSS	
DEPITI	NMKRCD01
RADHI	
RADLO	
APPAT	
NINFO	
RESEL	
ADINFF	NMKRCD02
RESGR	
SHIP	
STRK	
SYTRK	
PLRTE	
APLRTE	NMKRCD03
UIECK	
UIEDR	
UIAFD	
UIAFF	
UIINF	
UIINF	
UIINF	
UIINFG	NMKRCD04
UIINFB	
UIINFM	
OUTLW	
OUTLL	
RESSO1	
RESSO2	
RESSO3	
RESSO4	
RESSO5	

### TOPMARI1

Conditional symbology procedure for symbolization of objects of the class topmar (Top Mark)

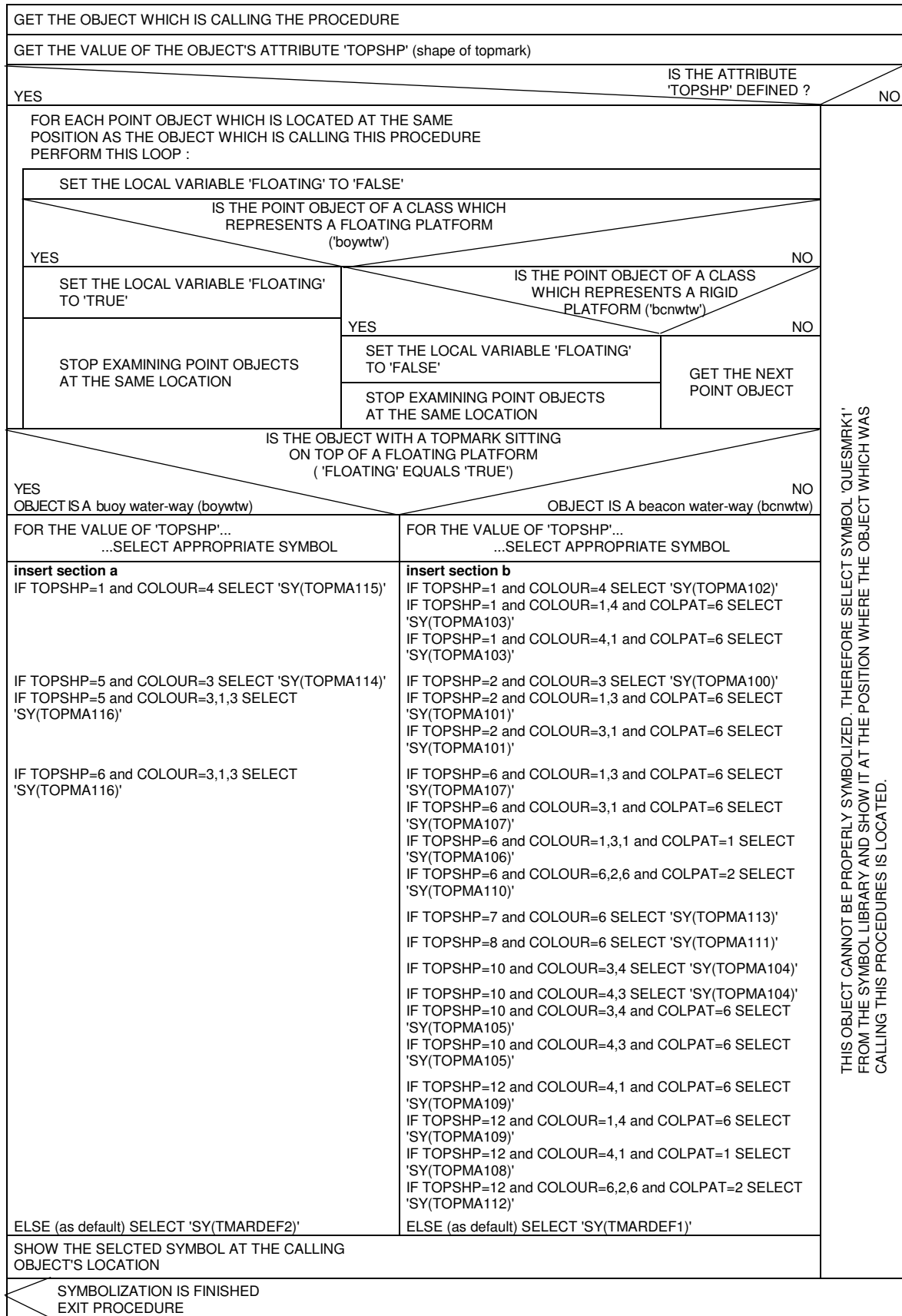

THIS OBJECT CANNOT BE PROPERLY SYMBOLIZED. THEREFORE SELECT SYMBOL 'QUESMRK1' FROM THE SYMBOL LIBRARY AND SHOW IT AT THE POSITION WHERE THE OBJECT WHICH WAS CALLING THIS PROCEDURES IS LOCATED.

Edition 1.02  
16.10.2003

## **Standard**

# **Electronic Chart Display and Information System for Inland Navigation**

## **Inland ECDIS**

---

---

### **SECTION 4**

---

---

# **Operational and performance requirements, methods of testing and required test results**

Appendices:

- A Software Quality Assurance
- B System Configurations (Figures)

## Contents

<b>1</b>	<b>Introduction.....</b>	<b>161</b>
1.1	Scope of this document .....	161
1.2	Normative references .....	161
<b>2</b>	<b>Operating modes and system configuration.....</b>	<b>161</b>
2.1	Operating modes .....	161
2.2	System configurations .....	162
<b>3</b>	<b>Performance requirements.....</b>	<b>162</b>
3.1	Hardware performance.....	162
3.2	Software performance .....	162
3.3	Performance of operation controls .....	163
3.4	Display performance.....	163
<b>4</b>	<b>Operational functions .....</b>	<b>164</b>
4.1	Operating mode .....	164
4.2	Equipment pre-sets (store/recall) .....	164
4.3	Presentation of SENC information .....	164
4.4	Chart orientation, positioning and shifting .....	165
4.5	Position and bearing of the own ship .....	165
4.6	Information density .....	165
4.7	Ranges / Range rings.....	165
4.8	Picture Brilliance.....	166
4.9	Picture colours.....	166
4.10	Pick report.....	166
4.11	Measuring features.....	166
4.12	Input functions .....	9
4.13	Loading and updating of SENC's .....	166
4.14	Radar picture presentation and overlay .....	167
4.15	Functions with immediate access.....	167
4.16	Permanent visible function parameters .....	167
<b>5</b>	<b>Service functions.....</b>	<b>167</b>
5.1	Static correction of the chart position .....	167
5.2	Static correction of the chart orientation.....	168
5.3	Configuration of interfaces.....	168

---

<b>6</b>	<b>Hardware test and required certificates</b> .....	<b>168</b>
6.1	Compatibility with the environmental requirements.....	168
6.2	Equipment documentation.....	168
6.3	Interfaces.....	169
6.4	Characteristic of operation controls.....	169
6.5	Characteristic of the display.....	169
<b>7</b>	<b>Test of the chart presentation, operation and functionality</b> .....	<b>169</b>
7.1	Preparation of the Equipment Under Test (EUT).....	169
7.2	Test of the operation modes.....	169
7.3	Test of the displayed objects.....	169
7.4	Test of the scale dependent information density (SCAMIN) .....	169
7.5	Test of the brilliance variation.....	170
7.6	Test of the colours.....	170
7.7	Test of the measurement functions.....	170
7.8	Test of the chart update function.....	170
7.9	Test of displayed objects in more than one cell of the same usage for the same area ...	170
<b>8</b>	<b>Test of the radar picture presentation and -operation</b> .....	<b>170</b>
8.1	Preparations .....	170
8.2	Test of the radar picture without underlayed chart.....	171
8.3	Test of the radar picture and the underlayed chart .....	171
<b>9</b>	<b>Test of alarms and indications</b> .....	<b>172</b>
<b>10</b>	<b>Test of fall back arrangements</b> .....	<b>172</b>

## 1 Introduction

### 1.1 Scope of this document

This section 4 of the Inland ECDIS Standard specifies the minimum requirements contained in section 1 and describes the test procedures and the required results concerning the hardware, the software, the functions, the operation, the display and the interfaces to other equipment on board of ships.

### 1.2 Normative references

References to the following normative documents are made in this document in addition to the references in section 2, ch. 2.2 of this standard:

EN 60945 (1997)	Marine navigational equipment; General requirements - Methods of testing and required test results
IEC 1174:	ECDIS - Operational and performance requirements, methods of testing and required test results
ISO 9000 (1987)	Quality management and quality assurance standard
CCNR Decision 1989-II-33:	Standard on the minimum requirements and on the required test results for navigational radar equipment in the Rhine navigation
CCNR Decision 1989-II-34:	Standard on the minimum requirements and on the required test results for rate-of-turn indicators in the Rhine navigation
CCNR Decision 1989-II-35:	Standard on the installation and on functional tests of navigational radar equipment and of rate-of-turn indicators in the Rhine navigation
EU-Directive 1999/5/EC:	Radio Equipment and Telecommunications Terminal Equipment and the Mutual Recognition of their Conformity

## 2 Operating modes and system configuration

### 2.1 Operating modes

- a) The Inland ECDIS Standard distinguishes two operating modes: **navigation mode** and **information mode**.
- b) Inland ECDIS equipment designed for operating in **navigation mode** has to fulfil the requirements of this standard and the standards on navigational radar equipment and rate-of-turn indicators to be proven by conformity tests.
- c) For Inland ECDIS equipment designed for **information mode** only, the requirements of this section 4 are to be understood as a recommendation.

## **2.2 System configurations**

### **2.2.1 Inland ECDIS equipment, stand-alone-system without connection to radar**

In this configuration only operation in **information mode** is possible (see Appendix B, Fig. 1).

### **2.2.2 Inland ECDIS equipment, parallel installation and connection to radar**

This configuration allows operation in **information mode** as well as in **navigation mode** (see Appendix B, Fig. 2).

### **2.2.3 Inland ECDIS equipment, monitor shared with connected radar equipment**

In special cases, it is possible to share one display for the Inland ECDIS equipment and for the radar equipment. The prerequisite for this is a monitor with matching graphic parameters for both video signals, and a video switch, which allows a fast switchover of the video sources, and – if needed - a mechanical rotation of the display to the required orientation (see Appendix B, Fig. 3).

### **2.2.4 Radar equipment with integrated Inland ECDIS functionality**

This is a radar installation with integrated Inland ECDIS functionality that can be operated in **information mode** as well as in **navigation mode** (see Appendix B, Fig. 4).

## **3 Performance requirements**

### **3.1 Hardware performance**

- a) Inland ECDIS equipment shall be designed and manufactured to withstand typical environmental conditions prevailing on board of a vessel without any degradation in quality and reliability. Furthermore, it shall not disturb other communication and navigation equipment.
- b) In the configuration as described in paragraph 2.2.4 all components of inland ECDIS equipment, installed inside the wheelhouse, shall fulfil the requirements of the class b) "protected from weather" equipment as specified in the standard EN 60945 with the exception that the test temperature range is limited to 0°C to +40°C (whereas the test temperature range in EN 60945 is specified from – 15°C to + 55°C) unless specified differently in this document. For the configurations described in paragraph 2.2.2 and 2.2.3 CE conformity is sufficient.

### **3.2 Software performance**

Operation, visualisation, and functionality of Inland ECDIS equipment are usually realised by software. Taking this into account, the software shall be designed, developed, implemented, and tested according to the generally accepted state of the art. Therefore, the manufacturer shall fulfil the software requirements described in Appendix A to this document.



### **3.3 Performance of operation controls**

- a) The operation of the system shall be simple, appropriate and conform to common human interface standards.
- b) The number of operational controls shall be as low as possible and restricted to the required number.
- c) Wireless remote controls are not admitted.
- d) The ON/OFF switch is to perform and to be arranged in such a way that inadvertent operation is not possible.
- e) The symbols of the operating controls need a minimum character height of 4 mm and shall be readable under all conditions that may exist in a wheelhouse.
- f) The brilliance and the illumination of the operating controls should be adjustable to the required value.

### **3.4 Display performance**

#### **3.4.1 Display dimensions**

In **navigation mode** the minimum chart and radar display area is 270 mm x 270 mm.

#### **3.4.2 Display orientation**

- a) A rectangular display may be mounted in landscape or in portrait orientation under the prerequisite that the above mentioned minimum dimensions are fulfilled.
- b) Because of the limited space available in the typical wheelhouse of an inland vessel and the fact that a vessel usually follows the fairway-axis, the display shall be installed preferably in the portrait orientation.

#### **3.4.3 Display resolution**

A display resolution of 5 m in the 1,200 m range is required. This leads to a maximum pixel dimension of 2.5 m x 2.5 m, i.e. about 1,000 pixels at the short edge of the display.

#### **3.4.4 Display colours**

The system shall be able to display ergonomically proven colour combinations for day and night.

#### **3.4.5 Display brilliance**

The brilliance of the display shall be adjustable to every operational required value. This is especially valid for the lowest value during operation at night.

### 3.4.6 Picture renewal

- a) The picture renewal rate shall not be shorter than that of the radar picture ( $\geq 24$  pictures per minute).
- b) Between two consecutive renewals no fluctuations of brilliance may occur.
- c) On raster scan displays, the frame repetition rate may not be lower than 60 Hz.

### 3.4.7 Display technology

Preferably such display systems shall be used that are insensitive to the magnetic fields that may occur in the wheelhouse of an inland vessel.

## 4 Operational functions

### 4.1 Operating mode

- a) If the equipment is able to work in both operation modes it shall provide the possibility to switch between **navigation mode** and **information mode**.
- b) The operation mode in use shall be displayed.
- c) Suitable measures are required to prevent inadvertent switching off of the **navigation mode**.

### 4.2 Equipment pre-sets (store/recall)

- a) After invoking, the Inland ECDIS equipment shall come up with a moderate brilliance pre-set which neither blinds in a dark environment nor makes the picture invisible in a bright environment.
- b) Other parameters may come up with their values at the time before switching off or from stored settings.

### 4.3 Presentation of Inland SENC information

*Inland SENC = Inland System Electronic Navigational Chart*

- a) The radar picture shall be clearly distinguishable from the chart independently of the chosen colour table.
- b) Only a monochrome presentation of the actual radar picture is permitted.
- c) The presentation of chart information shall not mask or degrade important parts of the radar picture. This has to be ensured by appropriate entries into the look-up tables (ref. to section 3 of this standard, appendix A, ch. 2.1, field "radar code").
- d) In **navigation mode**, chart and radar picture presentation shall have the same scale.
- e) The heading line must be always visible.
- f) Additionally, the mariner's own ship's contour and the safety contours may be inserted.

#### 4.4 Chart orientation, positioning and shifting

- a) In **navigation mode**, only the chart orientation "relative motion, head up" and the "centred" or "off centred" presentations, as required for the radar picture, are permitted.
- b) In **information mode**, at least the chart orientations north and parallel to the waterway axis as well as positioning are recommended. By connection of a positioning sensor, the displayed part of the chart can automatically follow the mariner's own ship's position.

#### 4.5 Position and bearing of the own ship

- a) In **navigation mode**, the own ships position shall always be visible in the display area, whether centred or off centred as specified in the CCNR radar requirements.
- b) The heading line, which runs from the display centre to the top and which always shall be visible, shall represent the heading of the mariner's own ship.

#### 4.6 Information density

The information density shall be at least adjustable to the three switchsteps: "Minimum", "Standard" and "All Information". The latter displays all other objects in addition to the "Standard" display, individually on demand. All corresponding visible objects are defined in the "Performance Standard" and the "Presentation Standard (Presentation Library)" (Sections 1 and 3 of the Inland ECDIS Standard).

#### 4.7 Ranges/Range rings

- a) In **navigation mode** the following fixed ranges and range rings are prescribed according to the radar regulations:

Range	Range rings
500 m	100 m
800 m	200 m
1.200 m	200 m
1.600 m	400 m
2.000 m	400 m

- b) Both, smaller as well as larger ranges with a minimum of four and a maximum of six range rings are permitted.
- c) Inland ECDIS equipment in **navigation mode** shall have fixed range rings with the above mentioned intervals and at least one variable range marker (VRM).
- d) Switching on/off of fixed and variable range markers shall be independent of each other and their display shall be clearly distinguishable.
- e) The position of the VRM and the corresponding displayed distance shall use the same incrementation and resolution.
- f) The functions of the VRM and the electronic bearing line (EBL) may additionally be realised by a cursor and by a corresponding numerical display, showing range and bearing of the cursor position.
- g) For **information mode** the same ranges are recommended.

#### 4.8 Picture Brilliance

- a) The brightness of the display shall be adjustable to the operationally necessary value. This applies in particular to operation in darkness.
- b) Chart and radar picture require separate brightness controls.
- c) Because of the strongly different environment brightness of bright day and dark night, another control for the basic brightness of the display shall be available additionally to the colour tables in the menu.

#### 4.9 Picture colours

At least the colour combinations included in the IHO-S-52 Presentation Library, ch. 4 and 13 (*colour tables*) for bright day, white-back day, black-back day, dusk and night shall be supported.

#### 4.10 Pick report

- a) In **navigation** mode, it shall be possible to get all information concerning the objects that are displayed in the chart. By moving the cursor to the desired point in the chart and clicking it with the mouse, the addressed point shall be marked by a symbol. At the same time, a window (pick report) shall be opened with textual and/or graphical information about all objects existing at that point.
- b) The pick report window may only be shown in the designated areas outside of the screen section that is preserved for the navigational chart.

#### 4.11 Measuring features

- a) Measuring features for distances and bearings are required.
- b) Resolution and accuracy shall at least be the same as those of the display, but may not suggest better values than those of the chart data.

#### 4.12 Input and editing of skippers' own chart entries

- a) Inland ECDIS equipment shall allow input, storing, modifying, and deletion of additional chart information by the skipper (*skippers' own objects*).
- b) These own chart entries shall be distinguishable from the SENC data, and may not overlay or degrade the radar picture.

#### 4.13 Loading and updating of SENC's

- a) All **manual** activities concerning loading or updating of charts shall be possible only outside the navigation mode.
- b) **Automatic** updating shall not downgrade the performance of the navigation display.
- c) A **roll-back function** has to be implemented to allow restoring to the last working combination.

#### **4.14 Radar picture presentation and overlay**

- a) The radar image representation is mandatory for operation in the navigation mode.
- b) The dimensions, resolution and attributes of the radar presentation shall fulfil the relevant radar requirements.
- c) The radar picture must not be degraded by other contents of the picture (see .4.3.c)
- d) Provided the functional requirements are fulfilled, overlaying of different picture layers is permitted.
- e) It shall be possible to switch off the chart and to display only the radar picture.
- f) If the quality and plausibility monitors of the Inland ECDIS equipment detect that the chart cannot be oriented and/or positioned with the accuracy required by this document, an alarm shall be presented on the display and the chart shall be switched off automatically.

#### **4.15 Inland ECDIS functions with immediate access**

- a) The following operational functions require direct access:
  - RANGE
  - BRILLIANCE
  - COLOURS
  - INFORMATION DENSITY
- b) These functions need either own control elements or own menu areas, which are arranged in the highest menu level and are permanently visible.

#### **4.16 Permanent visible function parameters**

The following function parameter shall be always visible:

- actual RANGE
- sensor STATUS (radar tuning, position quality, alarms)
- selected WATER LEVEL (if available)
- selected SAFETY DEPTH (if available)
- selected INFORMATION DENSITY

### **5 Service functions**

Service functions shall be protected by a password or other suitable measures against unauthorised access and shall not be selectable in navigation mode.

#### **5.1 Static correction of the chart position**

- a) The position of the mariner's own ship shall be presented centred or off centred on the display in accordance with the radar requirements. The chart position shall match the radar image. Assuming an absolute position's input the permissible static difference between actual radar position and displayed radar centre shall not exceed 1 m.

- b) It shall be possible to correct an offset error (distance between the positions of the position sensor and the radar sensor).

## **5.2 Static correction of the chart orientation**

- a) The difference between the heading line orientation and the ship's axis shall not be greater than  $\pm 1.0$  deg.
- b) Chart and radar image shall have the same orientation. The static directional error between heading line and chart orientation shall be less than  $\pm 0.5$  deg.

## **5.3 Configuration of interfaces**

- a) It shall be possible to configure interfaces for connected sensors, actors and signals (*An actor transforms an electrical quantity into another physical quantity (e.g. optical). An actor is the opposite of a sensor.*)
- b) Interfaces shall comply with existing interface specifications like the NMEA 01/83 standard and the interface specifications for rate of turn indicators (20 mV/deg/min).

## **6 Hardware test and required certificates**

- a) The test consists of a comparison between the equipment under test (EUT) and the requirements of this document.
- b) Proved equivalent tests, and proved and documented test results will be accepted without renewed tests.

### **6.1 Compatibility with the environmental requirements**

- a) Inland ECDIS equipment, as described in paragraph 2.2.4, shall fulfil the requirements of the Standard EN 60 945 concerning the environmental conditions (humidity, vibration and temperature) (the latter reduced according to chapter 3.1 of this document) and concerning electromagnetic compatibility.
- b) The provider or his representative is obliged to submit a relevant conformity declaration of an accredited laboratory.

### **6.2 Equipment documentation**

The technical documentation will be checked to be complete, appropriate, and understandable, and to be sufficient for unproblematic installation, configuration and operation of the equipment.

### **6.3 Interfaces**

- a) All interfaces shall be documented correctly and completely.
- b) Electronic Circuits need to be designed failsafe, mechanically as well as electronically, and may not have degrading repercussions on connected equipment.

### **6.4 Characteristic of operation controls**

All operation controls will be checked regarding the ergonomic and functional mode of operation and shall fulfil the requirements of this document.

### **6.5 Characteristic of the display**

The display shall fulfil all requirements of this document concerning dimension, displayable colours, resolution, and variation of brilliance.

## **7 Test of the chart presentation, operation and functionality**

### **7.1 Preparation of the “Equipment under test” (EUT)**

The EUT will be installed, assembled and connected according to the installation manual. After switching on the test SENC will be loaded.

### **7.2 Test of the operation modes**

All operating modes as described in the operating manual will be successively invoked and tested. The requirements of chapter 4 shall be fulfilled.

### **7.3 Test of the displayed objects**

It will be tested if all objects included in the test SENC are visible and correctly displayed. For this test, the information density will be switched to “all objects”.

### **7.4 Test of the scale dependent information density (SCAMIN)**

- a) Whether the SCAMIN functionality (*the minimum scale at which the object may be used for ECDIS presentation*) is installed correctly will be tested.
- b) For this test, the range will be used at which the object shall be visible according to its SCAMIN attribute value (ref. to the IHO-S-57 Attribute Catalogue and the IHO-S-52 Users Manual to the Presentation Library, ch. 8.4).

## 7.5 Test of brilliance variation

The Inland ECDIS equipment will be operated in a dark room and the brilliance will be brought to its lowest level. The brilliance of the objects shall not exceed a value of 15 cd/m<sup>2</sup>, and the background a value of 0,5 cd/m<sup>2</sup>.

## 7.6 Test of the colours

All user selectable S-52 colour tables will be sequentially tested to conform to this document.

## 7.7 Test of the measurement functions

- a) All numeric displayed values of the electronic bearing line (EBL) and the variable range marker (VRM) shall exactly match with the analogue positions of the EBL and the VRM (or correspond with the cursor co-ordinates).
- b) The resolution and incrementation of the numerical display shall be identical with the analogue values of EBL and VRM.

## 7.8 Test of the chart update function

- a) Before and after every test step the version numbers of the loaded SENCs and updates will be recalled as described in the operation manual and showed on the display.
  - Step 1: Loading of the test SENC,
  - Step 2: Update of the test SENC,
  - Step 3: Test of the roll-back function,
  - Step 4: Loading of a new SENC.

After an update it should be possible to recall and display all objects concerned.

## 7.9 Test of displayed objects in more than one cell of the same usage for the same area

It will be tested whether all objects included in the test SENC and in the additional overlay test SENC are visible and correctly displayed. For this test the information density will be switched to "all objects". It will be tested whether it is possible to select one or more specific cells for presentation if there are several cells from different producers for the same area with the same usage.

# 8 Test of radar picture presentation and operation

## 8.1 Preparations

- a) For the test purposes, the manufacturer or provider has to provide a serial interface at the system to be approved (*Equipment under test* - EUT) which delivers the same actual values (as NMEA 01/83 strings) of position and heading that are used to position and orient the chart.
- b) During the test, a reference system will be used of which position and heading values are compared with those of the EUT.



- c) The EUT will be connected to any type approved radar equipment (to the choice of the provider).
- d) The radar picture will be adjusted in range and bearing with reference to the heading line.

## **8.2 Test of the radar picture without underlaid chart**

- a) If the Inland ECDIS equipment displays the radar picture but the radar operation control remains at the radar equipment (App. B, figures 2 and 3), the radar picture of the inland ECDIS equipment will be considered as the "daughter display" of an item of radar equipment. In that case, the radar picture has to fulfil the display and picture-relevant requirements of the requirements for radar and rate-of-turn indicators.
- b) If the EUT is a radar installation with integrated Inland ECDIS functionality (Appendix B, figure 4), all requirements of the standards for radar equipment and rate-of-turn indicators have to be fulfilled.

## **8.3 Test of the radar picture and the underlaid chart**

The Inland ECDIS equipment will be installed in a reference environment. This can be real (on a ship) or simulated.

### **8.3.1 Test of the picture overlay**

- a) The radar image shall not be degraded by the chart picture (ref. to ch. 4.3.c).
- b) The chart picture shall be renewed not later than the radar picture.

### **8.3.2 Test of the chart positioning and orientation**

- a) The static offset of the chart position shall be less than  $\pm 5$  m in all ranges up to 2,000 m.
- b) The static azimuth orientation offset error between radar and chart image shall be less than  $\pm 0,5$  deg.
- c) The correction of these parameters shall be demonstrated in the service mode.
- d) The dynamic deviation of the chart orientation at rates of turn less than  $\pm 60$  deg./min shall be less than  $\pm 3$  deg.
- e) These tests will be performed visually or by evaluation of measured data.

### **8.3.3 Test of scale conformity**

The chart's information will be compared with well-known reference points contained in the radar picture in order to test whether the chart scale sufficiently conforms to the radar scale.

## **9 Test of alarms and indications**

- a) The alarms generated from Inland ECDIS equipment itself as well as the passed alarms delivered by the connected sensors to the ECDIS will be tested.
- b) The test procedure comprises the following situations:
  - any error in the Inland ECDIS equipment (built-in test equipment - BITE),
  - missing positioning signal,
  - missing radar signal,
  - missing rate of turn signal,
  - missing heading signal,
  - radar map matching not possible,

## **10 Test of fall back arrangements**

- a) This test shall demonstrate the reaction of the Inland ECDIS equipment to a failure of any internal or external component and the possible and required actions by the operator.
- b) In addition, the operating manual will be checked to determine whether the measures required by the operator are described adequately and appropriately.

Edition 1.02  
16.10.2003

## **Standard**

# **Electronic Chart Display and Information System for Inland Navigation**

## **Inland ECDIS**

---

---

### **SECTION 4**

---

---

### **Operational and Performance Requirements, Methods of Testing and required Test Results**

## **Appendix A**

# **Measures to Ensure Software Quality**

## Contents

<b>1</b>	<b>General requirements .....</b>	<b>175</b>
1.1	Software design requirements .....	175
1.2	Implementation requirements .....	175
1.3	Test requirements .....	175
1.4	Third party components requirements .....	176
1.5	Requirements to additional services in navigation mode .....	176
1.6	Language .....	176
1.7	Documentation requirements for users.....	176
<b>2</b>	<b>Methods of testing and required results.....</b>	<b>176</b>
2.1	Navigation mode operation test .....	176
2.2	General software tests .....	178
<b>3</b>	<b>Changes on certified systems .....</b>	<b>179</b>
3.1	General requirements .....	179
3.2	Hardware and software changes .....	179

## 1 General requirements

Software used in navigation mode is assumed to be a safety-relevant part of a navigation system. Providers of navigation systems have to make sure that all software components used in navigation mode allow secure navigation in every situation.

### 1.1 Software design requirements

Software components have to be clearly designed by means of established software design methods. The design specification must indicate how safety requirements are addressed in the software design. A software style guide has to be provided that specifies code writing style, documentation style, modularization, conflict analyses and testing of software components. For every software component documents describing specification and design are required.

### 1.2 Implementation requirements

Implementation of software modules has to be done by qualified developers, fully understanding the design and safety requirements.

If more than one developer is working on the navigation system software, a version control system has to be used that guarantees conflict-free development.

The implementation has to be according to the design specification and has to reflect the software style guide. Moreover, well known implementation problems (depending on the language used) have to be addressed in the implementation. This includes but is not restricted to:

- null pointer handling,
- uninitialised variables,
- range checking,
- array size verification,
- memory allocation and de-allocation,
- exception handling.

If parallel processing is used (e.g. multiple threads, tasks or processes) problems of conflict-free processing have to be addressed in the implementation. This includes but is not restricted to:

- race conditions,
- re-entrance problems,
- priority inversion,
- deadlocks.

### 1.3 Test requirements

In accordance with the design specification, software modules have to be tested. The test results have to be compared with the design guidelines and documented in test reports.

Tests have to incorporate module as well as system tests. Providers of a navigation system have to use extensive simulator-based tests to ensure stability of their system. The simulator must allow the simulation of a complete navigation environment including all required external sensors.

#### **1.4 Third party components requirements**

Third party components (OEM products, OEM means original equipment manufacturer) include software not developed by the navigation system provider. This includes but is not restricted to

- static or dynamic linked libraries,
- computer aided design and engineering tools producing source or object code,
- operating systems.

Third party software components have to be chosen according to the general safety requirements. The navigation system provider has to prove that third party components meet the high standards necessary for safe navigation either by providing acceptable quality certificates or by extensive and provable testing of the components

#### **1.5 Requirements for additional services in navigation mode**

Navigation systems may support additional services in navigation mode if they are useful. These services must not interfere with navigation mode.

The navigation system provider is responsible for additional test equipment, necessary to verify interface specification, protocol specification and compliance tests with the Inland ECDIS standard.

#### **1.6 Language**

Additional national versions of a type-approved Inland ECDIS shall reapply for type approval to be checked for the translation of the user interface.

#### **1.7 Documentation requirements for users**

The documentation (manuals) has to contain comprehensive information on installation, operation and service of the navigation system. The presentation of user-relevant information shall be made clear, understandable and without unnecessary technical terms. The user manual shall be available in the official CCNR languages. The technical documentation may be made available in English only.

## **2 Methods of testing and required results**

### **2.1 Navigation mode operation test**

#### **2.1.1 Performance requirements**

Navigation systems must make reliable estimations of position and heading. Moreover, the estimation of position and heading has to be checked by the system for conformity with the required accuracy.

Position and heading information has to be calculated and displayed for the same reference position. This should normally be the centre of the radar antenna. A new position estimate must at least be available with every revolution of the radar antenna.

### 2.1.1.1 Position

The navigation system has to estimate and display the position of the ship. The following minimal requirements have to be fulfilled under normal operation conditions:

- a) The average position estimation shall not deviate more than 5 meters from the true position and shall cover all systematic errors.
- b) The standard deviation  $\sigma$  has to be less than 5 meters and shall be based on random errors only.
- c) The system shall be capable to detect deviations of more than  $3\sigma$  within 30 seconds.

These results have to be verified by a realistic test of at least 60 min.

### 2.1.1.2 Heading

The navigation system has to estimate and display the heading of the ship.

The following minimal requirements have to be fulfilled:

- a) The average heading angle estimation shall not deviate more than 1 degree from the radar heading direction and shall cover all systematic errors. The offset between ship heading direction and radar heading shall be less than 1 degree.
- b) The standard deviation  $\sigma$  has to be less than 2 degrees and shall be only based on random errors.

These results have to be verified by a realistic test of at least 60 min.

### 2.1.2 Sensor failure

Navigation systems have to check proper operation of the position and heading estimation online. Problems have to be detected within 30 seconds. In case of malfunction, the navigation system has to inform the user about the problem and its consequence for navigation.

If reliable navigation is not possible the navigation chart should not be displayed.

### 2.1.3 Performance test interface

A navigation system provider has to equip navigation systems during the compliance test with a standard NMEA interface sending the position and heading information used by the navigation system. This information has to be encoded by NMEA sentences known as GGA and PAT.

#### Example: GGA - Global Position System Fix Data

```
$GPGGA,123519,4807.038,N,01131.324,E,1,08,0.9,545.4,M,46.9,M, , *42<CR><LF>  
123519 Fix taken at 12:35:19 UTC. (This field has to provide the time of the position  
estimation.)
```

4807.038,N	Latitude 48 deg 07.38' N (This field has to provide the latitude of the fix.)
01131.324,E	Longitude 11 deg 31.324' E (This field has to provide the longitude of the fix.)
1	Fix quality (0 = invalid, 1 = GPS fix, 2 = DGPS fix (This field can have any valid value.)
08	Number of satellites being tracked. (This field can have any valid value.)
0.9	Horizontal dilution of position (This field can have any valid value.)
545.4,M	Altitude, Metres, above mean sea level. (This field is can have any valid value.)
46.9,M	Height of geoid (mean sea level) above WGS 84 ellipsoid. (This field can have any valid value.)
(empty field)	Time in seconds since last DGPS update. (This field can have any valid value.)
(empty field)	DGPS station ID number. (This field can have any valid value.)

**Example: PAT - Position and altitude message  
(Ashtech proprietary position and altitude message.)**

\$GPPAT,223924.0,3922.2871,N,12159.4503,W,+/-00253.2,121.673,+/-002.59,+/-004.61,.....  
...0.0031,0.0205,0<CR><LF>

223924.0	UTC of position. (This field has to provide the time of the position estimation.)
3922.2871,N	Latitude 39 deg 22.2871' N (This field has to provide the Latitude of the fix.)
12159.4503,W	Longitude 121 deg 59.4503' W (This field has to provide the Longitude of the fix.)
+/-00253.2	Altitude in meters. (This field can have any valid value.)
121.673	Heading in degrees. (This field has to provide the heading angle use by the navigation system.)
+/-002.59	Pitch in degrees. (This field can have any valid value.)
+/-004.61	Roll in degrees. (This field can have any valid value.)
0.0031	Attitude phase measurement error MRMS (meters). (This field can have any valid value.)
0.0205	Attitude baseline length rms error, BRMS (meters). (This field can have any valid value.)
0	Attitude reset flag ((0: good attitude, 1: rough estimate or bad attitude). (This field can have any valid value.)

Both strings have to be sent over the same NMEA interface at least every second. The position and heading have to be according to the definitions in section 2.1.1.1 and section 2.1.1.2 of this Appendix.

## 2.2 General software tests

### 2.2.1 Equipment documentation

The following documents have to be provided for admittance and have to be shipped with every navigation system:

- Users manual,
- Installation manual,
- Service manual.



The following documents and files have to be provided during the admittance procedure and are not required for end users:

- design specification,
- software style guide,
- certificates of third party software components or test and simulation protocols.

The documents and files provided must allow a complete verification of compliance with the Inland ECDIS standard.

### **2.2.2 Endurance test**

The navigation system must pass an endurance test of 48 hours of uninterrupted operation under normal operation conditions. The system has to provide standard interfaces for performance and resource monitoring during operation. Monitoring the system must show no indication of system instability, memory leaking or any kind of performance loss over time. Navigation systems supporting additional services while running in navigation mode provide the necessary test equipment including all documents mentioned in chapter 1.7 of this Appendix.

## **3 Changes to certified systems**

### **3.1 General requirements**

Navigation systems installed on board must be functionally equivalent to a system certified by authorities. For every system the navigation system provider must ship a statement of compliance with the Inland ECDIS standard and its functional equivalence to the certified system.

The competent authority is entitled to check Inland ECDIS compliance of installed systems at any time.

### **3.2 Hardware and software changes**

The navigation system provider can change software or hardware as long as Inland ECDIS compliance is maintained. Changes have to be fully documented and submitted to the competent authority together with an explanation of how the navigation system is affected by these changes. The competent authority can require a partial or complete renewal of certification if considered necessary. The aforementioned also applies to the use of an approved Inland ECDIS with another national version of the operating system.

The following changes do not affect certification of the system and require only a notice to the competent authority:

- minor changes on third party components (e.g. operation system or library updates),
- use of equivalent or better hardware components (e.g. faster microprocessor, newer)
- chip revisions, equivalent graphic card etc.),
- minor changes in source code or documentation

Page 180 intentionally left empty

Edition 1.02  
16.10.2003

**Standard  
Electronic Chart Display and Information System  
for Inland Navigation**

**Inland ECDIS**

---

---

**SECTION 4**

---

---

**Operational and Performance Requirements,  
Methods of Testing and Required Test Results**

**Appendix B**

**System Configurations**  
**Figures**

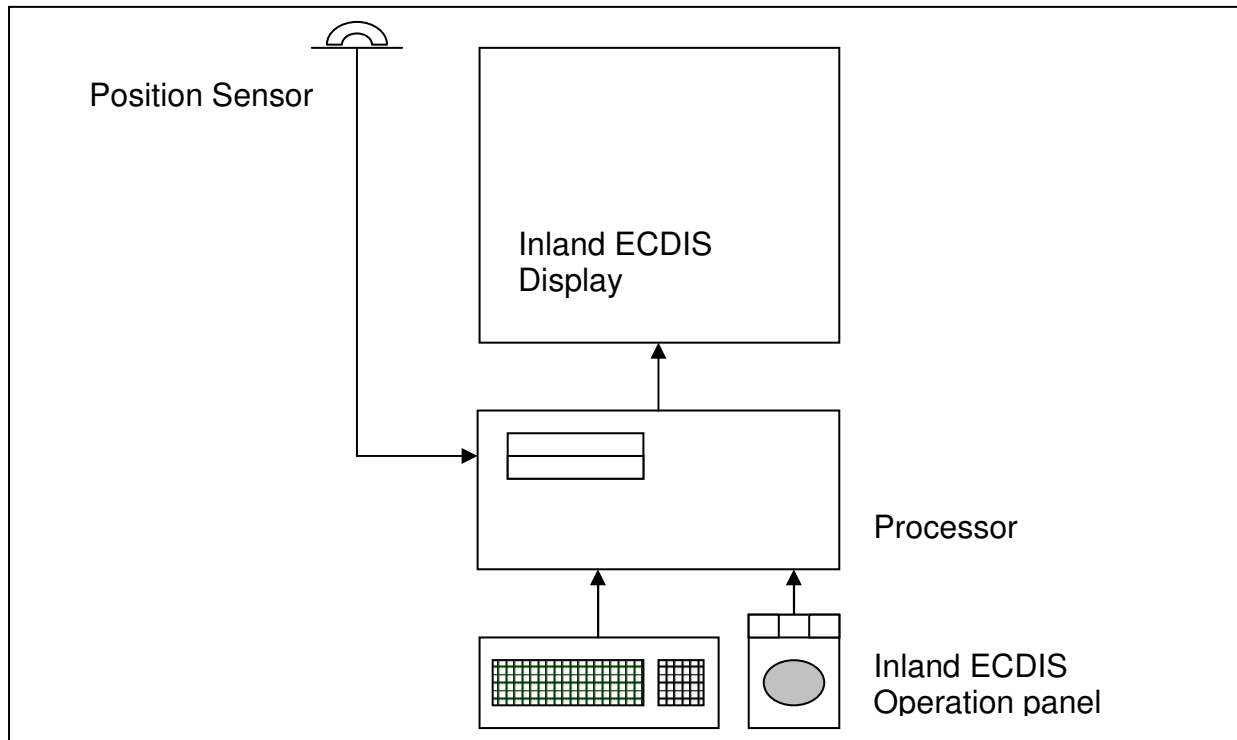

**Fig. 1: Inland ECDIS equipment, self-sufficient system without connection to radar**

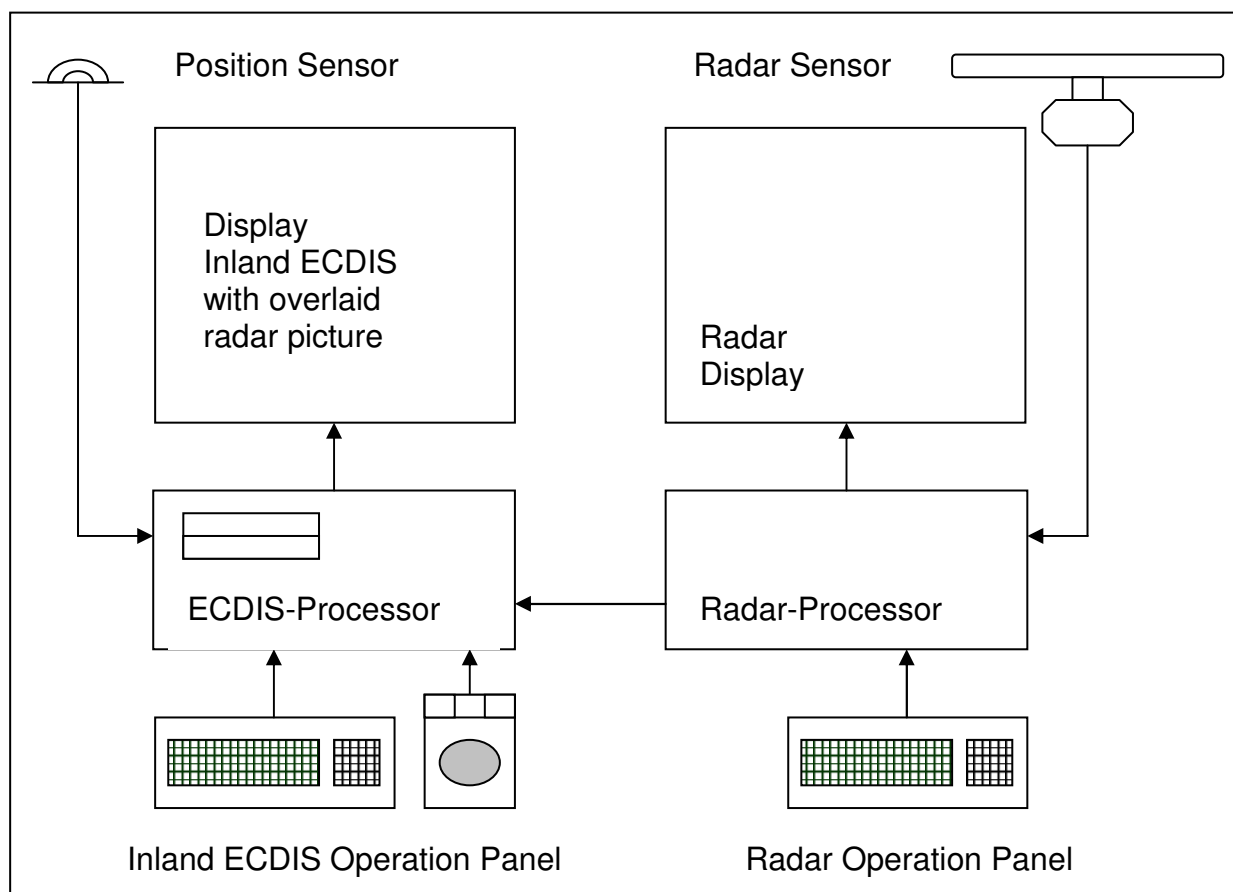

**Fig. 2: Inland ECDIS equipment, self-sufficient system with connection to radar**

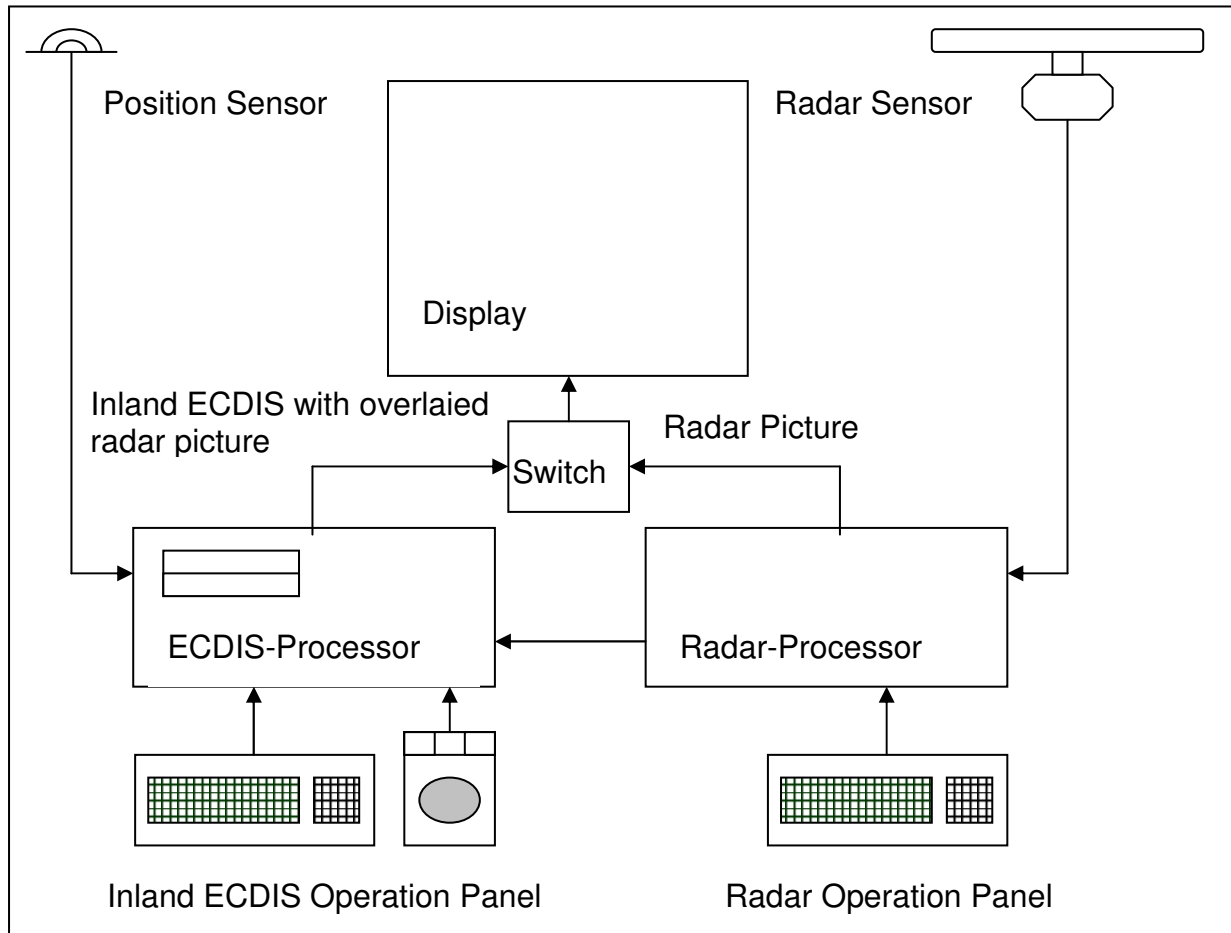

**Fig. 3: Inland ECDIS equipment with connection to radar and shared monitor**

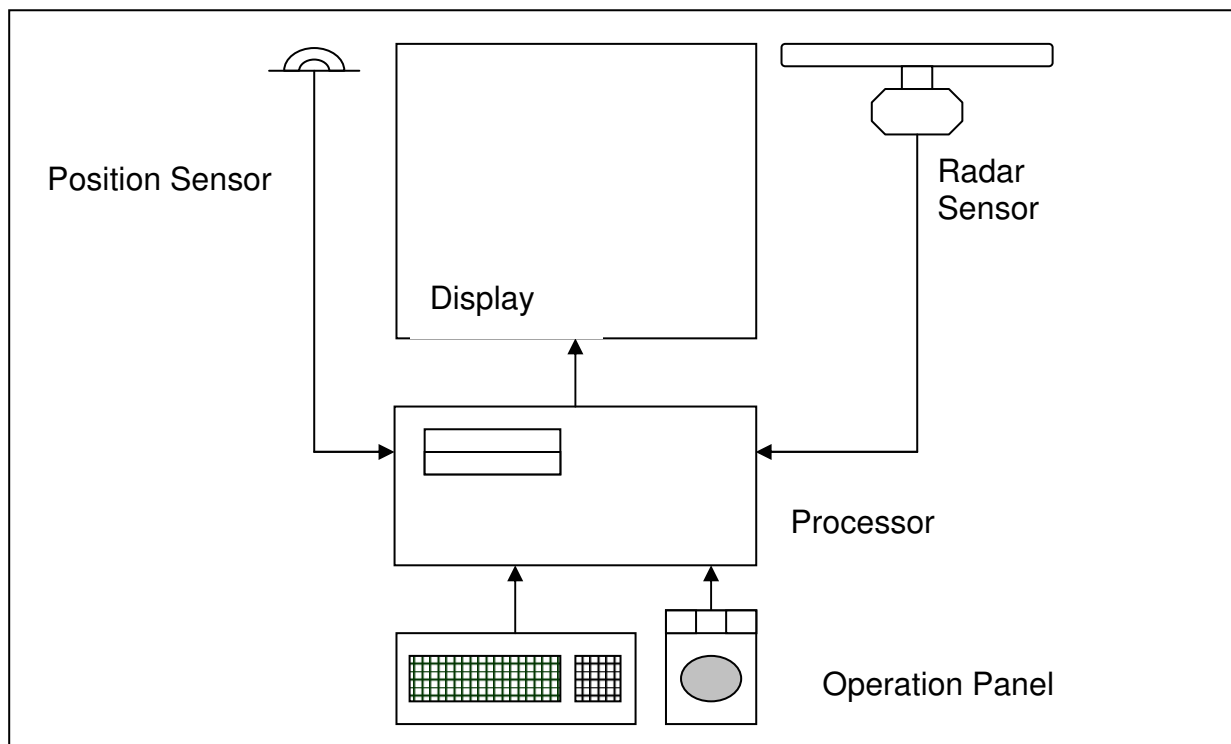

**Fig. 4: Navigational radar equipment with integrated Inland ECDIS functionality**

Page 184 intentionally left empty

Edition 1.02  
16.10.2003

## **Standard**

# **Electronic Chart Display and Information System for Inland Navigation**

*Electronic Chart Display and Information System  
for Inland ECDIS*

## **Inland ECDIS**

---

---

### **SECTION 5**

---

---

# **Glossary of Terms**

## Sources

- 1 IMO A.817(19)
- 2 IHO S-52
  - 2.1 IHO S-52, Appendix 3, Glossary
- 3 IHO S-57
- 4 Inland ECDIS Standard, Edition 1.0
  - 4.1 Section 1: Performance
  - 4.2 Section 2: Data
    - 4.2.1 Object Catalogue
  - 4.3 Section 3: Presentation
  - 4.4 Section 4: Operational Requirements and Tests
- 5 CCNR / ZKR: Radar Regulations
- 6 IEC 1174

### Remarks:

Definitions of the object classes and attributes are given in the tables of IHO S-57, Appendix A, Object Catalogue and on the Object Catalogue for Inland ECDIS (Section 2, Appendix A of this Standard)

Acronyms (e. g. ECDIS) are used in all language versions in the English form.

Pages 187 – 1990 are empty



Term or Abbreviation	Definition	Source
	<p style="text-align: center;"><b>English</b></p> <p style="text-align: center;"><b>Deutsch</b></p> <p style="text-align: center;"><b>Français</b></p> <p style="text-align: center;"><b>Nederlands</b></p>	
Acronym	<p>6-character-code of the object class/of the attribute</p> <p>6-Zeichen-Code der Objektklasse/des Attributs</p> <p>Code en 6 caractères de la classe d'objets/de l'attribut</p> <p>6 karakter code van de objectenklasse/van de attributen</p>	4.2.1
All information density	<p>All information density (all display) means the maximum amount of SENC information. Here, in addition to the standard display, also all other objects are displayed, individually on demand.</p> <p>Höchstinformationsdichte (alles) (<i>All information Display</i>) bedeutet den gesamten Informationsumfang der SENC. Hier wird zusätzlich zur Standardinformationsdichte auch der Rest der Objekte - bei Bedarf abgestuft - dargestellt.</p> <p>Densité maximale d'information (maximum) (<i>All information display</i>) désigne la densité maximale des informations du SENC. Outre la densité d'information standard, cette configuration permet d'afficher les autres objets, en plusieurs niveaux si nécessaire.</p> <p>"Maximale informatie (alles) betekend de complete hoeveelheid aan SENC informatie. Hier wordt, aanvullend aan de standaardinformatie, ook de rest van de objecten getoond, naar keuze instelbaar".</p>	4.1
Attribute	<p>A defined characteristic of an entity (e.g. the category of a light, the sector limits, the light characteristics etc.)</p> <p>Attribut; definierte Charakteristik einer Einheit (z.B. Kategorie eines Lichtzeichens, Sektorgrenzen, Helligkeitsstufen usw.)</p> <p>Attribut; la caractéristique définie d'une unité (par ex. la catégorie d'un feu de signalisation, les limites d'un secteur, les caractéristiques de luminosité etc.)"</p> <p>Een gedefiniëerde karakteristiek van een eenheid (bijv. Categorie van een licht, de sector grenzen, de licht karakteristieken etc.).</p>	2.1
Attribute copied	<p>S-57 attributes (with their complete list of attribute values) which were extended according to the requirements of Inland ECDIS. All new attributes have the same name like their source, but written in small case letters.</p> <p>Kopiertes Attribut; S-57-Attribut (mit der kompletten Liste ihrer Attributwerte) das gemäß der Anforderungen von Inland ECDIS erweitert wurde. Alle neuen Attribute haben den gleichen Namen wie das ursprüngliche Attribut, allerdings in Kleinbuchstaben geschrieben.</p> <p>Attribut copié; attribut S-57 (avec la liste complète des valeurs d'attributs) étendu conformément aux exigences du système ECDIS intérieur. Tous les nouveaux attributs portent le nom de l'attribut d'origine, mais écrit en minuscules.</p> <p>S-57 attributen (met de complete lijst van attribuut waarden) die zijn uitgebreid overeenkomstig de eisen van Inland ECDIS. Alle nieuwe attributen hebben dezelfde naam als het oorspronkelijke attribuut, maar worden in kleine letters geschreven.</p>	4.2.1
Attribute value	<p>A specific quality or quantity assigned to an attribute (e.g. "leading light", the limiting angles, the code specifying the light's colour - see attribute).</p> <p>Attributwert; zu einem Attribut gehörende spezielle Qualität oder Quantität (z.B. "Leitfeuer", Grenzwinkel, Code zur Festlegung der Farbe von Lichtzeichen - siehe Attribut)</p> <p>Valeur de l'attribut; la qualité ou quantité associée à un attribut (par ex. "feu de direction", angle limite, code de spécification de la couleur d'un signal lumineux – Cf. attribut)</p> <p>Bij een attribuut behorende speciale kwaliteit of hoeveelheid (bijv. geleide licht, de grens hoeken, de code die de kelur van het licht specificeert – zie attribuut)</p>	2.1

Term or Abbreviation	Definition	Source
	<p style="text-align: center;"><b>English</b></p> <p style="text-align: center;"><b>Deutsch</b></p> <p style="text-align: center;"><b>Français</b></p> <p style="text-align: center;"><b>Nederlands</b></p>	
Cartographic object	<p>Graphical object needed to satisfy certain presentation requirements mostly associated with a real world object. The attributes of a cartographic object (if any) provide additional drawing instructions. Examples: anchorage symbol associated with an anchorage area; textual annotations.</p> <p>Kartografisches Objekt; grafisches Objekt, das zur Erfüllung der Darstellungsanforderungen benötigt wird; meist in Verbindung mit einem real existierenden Objekt. Die Attribute eines kartografischen Objektes liefern zusätzliche Zeicheninstruktionen. Bsp. Ankersymbol in Verbindung mit Ankergebiet; textliche Anmerkungen.</p> <p>Objet cartographique; objet graphique nécessaire pour satisfaire aux exigences de la représentation, généralement en liaison avec un objet existant dans la réalité. Les attributs d'un objet cartographique fournissent des indications supplémentaires relatives à sa présentation, par ex. symbole d'une ancre en liaison avec une zone de mouillage; annotations textuelles.</p> <p>Grafisch object dat nodig is om aan bepaalde weergave eisen te kunnen voldoen, meestal in relatie tot het ware object. De attributen van een cartografisch object leveren aanvullende teken instructies. Bijv. anker symbool in samenhang met een ankergebied; tekstuele opmerkingen.</p>	2.1
CIE colour calibration	<p>Procedure to confirm that the colour specified in IHO S-52 appendix 2 is correctly reproduced on the ECDIS display.</p> <p>CIE-Farbenkalibrierung; Verfahren zur Gewährleistung, dass die in IHO S-52 Anhang 2 festgeschriebenen Farben korrekt auf dem ECDIS-Bildschirm wiedergegeben werden.</p> <p>Calibrage des couleurs CEI; procédure destinée à confirmer que les couleurs spécifiées dans le document OHI-S-52, appendice 2, sont correctement reproduites à l'écran ECDIS.</p> <p>Procedure om vastteleggen dat de in IHO S-52 vastgelegde kleuren correct op het ECDIS-beeldscherm worden weergegeven.</p>	6
Cell (chart cell)	<p>Predefined, scale dependant geographic area.</p> <p>Zelle (Kartenausschnitt); vorgegeben; maßstabsabhängige geografische Fläche.</p> <p>Cellule (partie de la carte); prédéfinie, aire géographique dépendant de l'échelle.</p> <p>Voor gedefiniëerde schaal afhankelijk geografisch gebied</p>	2.1
Collection object	<p>Type of feature object containing information about the relationships between other objects.</p> <p>Typ eines Merkmals-Objektes, das Informationen über Beziehungen von Objekten untereinander enthält.</p> <p>Type d'un objet caractéristique contenant des informations relatives aux liens entre d'autres objets.</p> <p>Type van een karakteristiek object, dat informatie over relatie tussen andere objecten bevat.</p>	4.2.1
Compilation scale	<p>The scale with which the chart information meets the IHO requirements for chart accuracy. It is established by the producing Hydrographic office and encoded in the ENC.</p> <p>Kompilations (zusammengetragener, zusammengestellter -) maßstab; der Maßstab, bei dem die Karteninformation exakt die IHO-Anforderungen hinsichtlich der Kartengenauigkeit erfüllt; wird vom Hersteller (hydrografische Behörde) festgelegt und in ENCs verschlüsselt.</p> <p>Echelle de compilation; l'échelle à laquelle l'information cartographique est parfaitement conforme aux exigences de l'IHO relatives à la précision de la carte. Elle est établie par le fabricant (administration hydrographique) et incorporée sous forme de code dans les ENC.</p> <p>De schaal waarmee de kaart informatie overeenkomt met de IHO eisen voor kaart nauwkeurigheid. Het wordt vastgesteld door de producerende hydrografische autoriteit en in de ENC geïncorporeerd.</p>	6

Term or Abbreviation	Definition	Source
	<p style="text-align: center;"><b>English</b></p> <p style="text-align: center;"><b>Deutsch</b></p> <p style="text-align: center;"><b>Français</b></p> <p style="text-align: center;"><b>Nederlands</b></p>	
Datum	<p>A set of parameters specifying the reference surface or the reference coordinate system used for geodetic control in the calculation of coordinates of points on the earth. Commonly datums are defined as horizontal and vertical datums separately. For the practical use of the datum it is necessary to have one or more well monumented points with coordinates given in that datum.</p> <p>Datensatz, der die Bezugsebene oder das Bezugskordinatensystem festlegt, die/das für die geodätische Überprüfung bei der Berechnung der Koordinaten von Punkten auf der Erde verwendet wird. Gewöhnlich sind Datensätze jeweils als horizontale und vertikale Datensätze definiert. Für die praktische Anwendung der Datensätze ist/sind ein oder mehrere markante (Referenz-) Punkt(e) mit Koordinaten in diesem Datensatz erforderlich.</p> <p>Série de paramètres spécifiant l'aire de référence ou le système des coordonnées de référence utilisés pour le contrôle géodésique lors du calcul des coordonnées de points sur la terre. Les séries de paramètres sont généralement définies en tant que séries horizontales et verticales de paramètres. L'application pratique des séries de paramètres nécessite un ou plusieurs points de référence marquants assortis des coordonnées de cette série de paramètres.</p> <p>Een set van parameters die het referentie vlak of het referentie coördinatie systeem gebruikt voor de geodetische controle bij de berekening van coördinaten van punten op de aarde specificeren. Gewoonlijk zijn gegevens gescheiden gedefiniëerd als horizontale en verticale gegevens. Voor de praktische</p>	2.1
Datum, horizontal	<p>A set of parameters specifying the reference for horizontal geodetic control, commonly the dimensions and the location of a reference ellipsoid.</p> <p>Datensatz, der den Bezug für die geodätische Überprüfung der horizontalen Koordinaten festlegt, gewöhnlich die Abmessungen und die Lage eines Referenzellipsoids.</p> <p>Une série de paramètres spécifiant la référence pour le contrôle géodésique horizontal, généralement les dimensions et la position d'un ellipsoïde de référence.</p> <p>Een set van parameters die de referentie voor de horizontale geodetie specificereert, gewoonlijk de dimensies en de plaats van een referentie ellipsiode</p>	2.1
Datum, vertical	<p>A surface to which elevations and/or depths (soundings and tide heights) are referred. For elevations commonly a level (equipotential) surface, approximately the mean sea level is used, for depths in many cases low water.</p> <p>Eine Ebene auf die sich Höhen bzw. Tiefen (Peilungen und Tidehöhen) beziehen; für Erhebungen (im Sinne von Höhen) gewöhnlich eine (einheitliche) Oberfläche, meist die Meeresebene (m über Normal Null), für Tiefen meist Niedrigwasser.</p> <p>Une surface à laquelle font référence les élévations et/ou les profondeurs (relèvements et hauteurs des marées); pour les élévations il s'agit le plus souvent d'une surface (équipotentielle), généralement le niveau de la mer (m &gt; NN) et les basses eaux pour la profondeur.</p> <p>Een vlak waarop zich de hoogte en de diepte (peilingen en getijde hoogte) zich betrekken. Voor verhogingen (in de zin van hoogtes) gewoonlijk een oppervlak, meestal de zeespiegel (m boven NAP), voor diepte meestal laag water.</p>	2.1

Term or Abbreviation	Definition	Source
	<p style="text-align: center;"><b>English</b></p> <p style="text-align: center;"><b>Deutsch</b></p> <p style="text-align: center;"><b>Français</b></p> <p style="text-align: center;"><b>Nederlands</b></p>	
Differential GPS (DGPS)	<p>A form of GPS in which the reliability and accuracy are enhanced by broadcasting a time-varying correction message from a GPS monitoring receiver (differential mode) at a known position on shore. The corrections are fed automatically into the GPS receiver onboard and used to compute an improved position.</p> <p>Eine Form von GPS, bei dem die Zuverlässigkeit und Genauigkeit beeinflusst werden von der Funkübertragung eines zeitverschobenen Korrektursignals von einem GPS-Empfänger (Differenzanteil, Unterschiedlichkeitsprinzip) in bekannter Position auf der Oberfläche. Die Korrekturen werden automatisch in den GPS-Empfänger an Bord eingespeist und zur Berechnung einer verbesserten Position verwendet.</p> <p>Une forme de GPS avec laquelle la fiabilité et la précision peuvent être améliorés par la transmission radioélectrique d'un signal temporisé de correction d'un récepteur GPS (mode différentiel) pour une position connue par rapport à la surface. Les corrections sont intégrées automatiquement par le récepteur GPS à bord et sont utilisées pour le calcul de la correction de la position.</p> <p>Een vorm van GPS, waarbij de betrouwbaarheid en de nauwkeurigheid beïnvloed wordt door de uitzending van een in tijd variërend correctiesignaal van een GPS ontvanger (differentieel modus) op een bekende positie aan land. De correcties worden automatisch in de GPS ontvanger aan boord geïntegreerd en voor de berekening van een verbeterde positie gebruikt.</p>	2.1
Display base	<p>Minimum information density; means the minimum amount of SENC information that is presented and which cannot be reduced by the operator, consisting of information that is required at all times in all geographic areas and under all circumstances.</p> <p>Basisanzeige, Mindestinformationsdichte; Mindestumfang an SENC-Information, der dargestellt wird und der durch den Betreiber nicht reduziert werden kann; enthält die Informationen, die jederzeit in sämtlichen geografischen Bereichen und unter allen Umständen erforderlich sind.</p> <p>Base de la visualisation, densité minimale d'information; désigne la quantité minimale d'information SCEN visualisable qui ne peut être réduite par l'utilisateur et contient les informations requises en permanence dans tous les secteurs géographiques et en toutes circonstances.</p> <p>Minimum informatie dichtheid, betekent de minimum hoeveelheid van SENC informatie dat wordt gepresenteerd en dat niet kan worden gereduceerd door de gebruiker; bevat de informatie dat onder alle omstandigheden wordt vereist in alle geografische gebieden.</p>	1
Display scale	<p>The ratio between a distance on the display and a distance on the ground, normalised and expressed as a ratio, e.g. 1:10 000.</p> <p>Anzeigemaßstab; das Verhältnis zwischen der Entfernung auf der Anzeige und der Entfernung auf der Erde, genormt und ausgedrückt als Maßstab, z.B. 1:10 000.</p> <p>Echelle d'affichage; le rapport entre la distance affichée et la distance réelle, normalisé et exprimé par une échelle, par exemple : 1:10 000.</p> <p>De verhouding tussen een afstand op de weergave en een afstand op de grond, genormaliseerd en uitgedrukt als verhouding, bijv. 1 : 10.000.</p>	6
EBL	<p><b>Electronic Bearing Line</b></p> <p>Elektronische Peillinie</p> <p>Relèvement électronique</p> <p>Elektrische peilingslijn</p>	5

Term or Abbreviation	Definition	Source
	<p style="text-align: center;"><b>English</b></p> <p style="text-align: center;"><b>Deutsch</b></p> <p style="text-align: center;"><b>Français</b></p> <p style="text-align: center;"><b>Nederlands</b></p>	
ECDIS	<p><b>Electronic Chart Display and Information System</b>; A navigation information system which can be accepted as complying with the up-to-date chart required by regulation V/20 of the 1974 SOLAS Convention, by displaying selected information from a system electronic navigational chart (SENC) with positional information from navigation sensors to assist the mariner in route planning and route monitoring, and if required display additional navigation-related information. The performance requirements for ECDIS are defined in the Performance Standard for ECDIS developed by IMO.</p> <p>Elektronisches Kartenanzeige- und Informationssystem; Navigations-Informationssystem, das mit den aktuellen Karten gemäß der Anforderung V/20 des SOLAS-Vertrages von 1974 übereinstimmt; Anzeige einer herstellerspezifischen (systemspezifischen) elektronischen Navigationskarte (SENC) mit Positions-Informationen von Navigationssensoren zur Unterstützung des Schiffsführers bei der Reiseplanung und Reiseüberwachung und auf Wunsch Anzeige von navigationsbezogenen Informationen. Die Leistungsanforderungen für ECDIS sind im Leistungsstandard für ECDIS definiert, der von der IMO erarbeitet wurde.</p> <p>Système de visualisation des cartes électroniques et d'informations; Système de renseignements sur la navigation correspondant aux cartes actualisées conformément aux exigences de la réglementation V/20 de la Convention SOLAS de 1974; et qui, en affichant des renseignements sélectionnés d'une carte électronique de navigation fonctionnelle (SENC) propre au fabricant (et au système) comportant des indications relatives à la position fournies par des capteurs et destinée à assister le conducteur lors de la planification et la surveillance du voyage par la mise à disposition d'informations relatives à la navigation affichables sur demande. Les exigences relatives aux performances du système ECDIS sont définis dans le standard de performance pour le système ECDIS élaboré par IMO.</p> <p>Elektronische kaart weergave en informatie systeem; een navigatie informatie systeem dat met de actuele kaart overeenkomstige de eisen V/20 van het SOLAS verdrag van 1974 overeenkomt, door weergave van geselecteerde informatie van een systeem elektronische navigatie kaart (SENC) met positieinformatie van navigatiesensoren ter ondersteuning van de schipper bij de reisplanning en reis monitoring en op verzoek weergave van aanvullende navigatie gerelateerde informatie. De prestatie eisen voor ECDIS zijn in de prestatie standaard voor ECDIS gedefinieerd, die door de IMO ontwikkeld werd.</p>	1
Edge	<p>A one-dimensional spatial object, located by two or more coordinate pairs (or two connected nodes) and optional interpolation parameters.</p> <p>Schneide, scharfe Kante, Rand, Saum; Eindimensionales räumliches Objekt, festgelegt durch zwei oder mehr Koordinatenpaare (oder zwei verbundene Knoten) und wahlweise Interpolationsparametern.</p> <p>Limite, arête, bord, lisière; objet spatial unidimensionnel représenté sur la base de deux (ou plus) paires de coordonnées (ou par deux points nodaux) et des paramètres optionnels d'interpolation.</p> <p>Rand; een eendimensionaal ruimtelijk object, vastgelegd door twee of meer coördinaten paren (of twee verbonden knooppunten) en optioneel interpolatie parameters.</p>	1

Term or Abbreviation	Definition	Source
	<p style="text-align: center;"><b>English</b></p> <p style="text-align: center;"><b>Deutsch</b></p> <p style="text-align: center;"><b>Français</b></p> <p style="text-align: center;"><b>Nederlands</b></p>	
ENC	<p>Electronic <b>N</b>avigational <b>C</b>hart; The data base, standardized as to content, structure and format, issued for use with ECDIS on the authority of government authorized hydrographic offices. The ENC contains all the chart information necessary for safe navigation and may contain supplementary information in addition to that contained in the paper chart (eg sailing directions) which may be considered necessary for safe navigation.</p> <p>Elektronische Navigationskarte; Datengrundlage standardisiert nach Inhalt, Aufbau und Form und durch staatliche hydrografische Behörden zur Verwendung von ECDIS herausgegeben; enthält alle für eine sichere Navigation notwendigen Karteninformationen und darf zusätzliche Informationen zu denen, die in der Papierkarte vorhanden sind (z.B. Fahrtrichtungen) enthalten, die als für die sichere Navigation wichtig angesehen werden.</p> <p>Carte Electronique de Navigation; base de données normalisée quant au contenu, à la structure et au format, qui est destinée à être utilisée avec le système ECDIS intérieur et est diffusée avec l'approbation des services hydrographiques agréés par les pouvoirs publics. La ENC contient tous les renseignements cartographiques nécessaires à la sécurité de la navigation et peut contenir d'autres renseignements que ceux fournis par la carte papier (des instructions nautiques, par exemple), qui sont jugés nécessaires à la sécurité de la navigation.</p> <p>Elektronische navigatie kaart; de database gestandaardiseerd naar inhoud, opbouw en vorm en door de bevoegde autoriteiten van het hydrografisch bureau uitgegeven voor gebruik met ECDIS.</p>	1
ENC cell	<p>The geographic division of ENC data for distributing purposes.</p> <p>ENC-Zelle (-Kartenabschnitt, d.A.); der geografische Kartenabschnitt der ENC für einen bestimmten Zweck.</p> <p>Cellule ENC; secteur géographique de la carte ENC réservé à une usage donné.</p> <p>ENC cel; het geografische gedeelte van de ENC voor een bepaald doel.</p>	6
Electronic chart	<p>Very broad term to describe the data, the software, and the electronic system, capable of displaying chart information. An electronic chart may or may not be equivalent to the paper chart required by SOLAS.</p> <p>Elektronische Karte; breitgefächerter Begriff zur Beschreibung der Daten, der Software und des elektronischen Systems für die Fähigkeit, Karteninformationen anzuzeigen. Die elektronische Karte kann aber muss nicht gleich der Papierkarte sein, die SOLAS fordert.</p> <p>Carte électronique; désignation générique utilisé pour la description de données, de logiciels et du système électronique capable d'afficher des informations cartographiques. La carte électronique ne doit pas nécessairement être identique à la carte imprimée exigée par SOLAS.</p> <p>Elektronische kaart; een brede term voor de beschrijving van data, de software en het elektronische systeem in staat kaart informatie weer yte geven. Een elektronische kaart kan maar moet niet gelijkwaardig aan een papieren kaart zijn die vereist is door SOLAS.</p>	2.1
Exchange Format	<p>A specification for the structure and organization of data to facilitate exchange between computer systems.</p> <p>Austauschformat; eine Beschreibung für die Struktur und Organisation von Daten zur Erleichterung des Austausches zwischen Computersystemen.</p> <p>Format d'échange; une spécification pour la structure et l'organisation de données visant à faciliter l'échange entre des systèmes informatiques.</p> <p>Wissel format; een beschrijving voor de structuur en organisatie van gegevens ter vereenvoudiging van een wisseling tussen computersystemen.</p>	2.1

Term or Abbreviation	Definition	Source
	<p><b>English</b></p> <p><b>Deutsch</b></p> <p><b>Français</b></p> <p><b>Nederlands</b></p>	
Exchange set	<p>Set of files representing a complete, single purpose (i.e. product specific) data transfer. For example, the ENC product specification defines an exchange set which contains one catalogue file and at least one data set file.</p> <p>Austauschsatz; Satz von Dateien für einen kompletten zweckgebundenen Datentransfer (z.B. produktspezifisch); z.B. definiert die ENC-Produktbeschreibung einen Austauschdatensatz, der eine Katalogdatei und eine Datensatzdatei enthält.</p> <p>Fichier d'échange; série de données pour un transfert de complet et déterminé de données (par ex. spécifique au produit), ainsi, la spécification de produit ENC définit un fichier d'échange comportant un fichier catalogue et un fichier de données.</p> <p>Wisselset; Serie van gegevens voor een complete doelgebonden datatransfer (bijv. product specifiek). Bijv. definieert de ENC product specificaties een wisselset die een catalogus bestand en een gegevens bestand bevat.</p>	1
Face	<p>A two dimensional spatial object. A face is a continuous area defined by a loop of one or more edges which bound it.</p> <p>(Ober-)Fläche; zweidimensionales räumliches Objekt; durchgängige Fläche definiert durch einen Linienzug (Schleife) von einem oder mehr Rändern, die diese begrenzen.</p> <p>Aire (surface); un objet bidimensionnel; une aire continue définie par un ligne (boucle) et délimitée par une ou plusieurs lignes.</p> <p>Vlak; een twee dimensionaal ruimte object. Een vlak is een continu gebied gedefinieerd door een lus van een of meer randen die deze verbinden.</p>	1
Feature Object	<p>An object which contains the non-locational information about real world entities. Feature Objects are defined in Appendix A, IHO Object Catalogue.</p> <p>Merkmals-Objekt; Objekt, das nicht-örtliche Information über die realen Gegebenheiten enthält; definiert in Anhang A, IHO Objektkatalog.</p> <p>Objet caractéristique; un objet qui contient des informations non-locales sur le contexte réel; défini à l'appendice A du catalogue d'objets de l'IHO.</p> <p>Karakteristiek object; een object dat de niet plaatselijke informatie over de werkelijkheid bevatten, gedefinieerd in Appendix A, IHO objecten catalogus.</p>	3
File	<p>An identified set of S-57 records collected together for a specific purpose. The file content and structure must be defined by a product specification.</p> <p>Datei; ein übereinstimmender Satz von S-57-Aufzeichnungen, zusammengestellt für einen bestimmten Zweck; Inhalt und Aufbau müssen durch eine Produktbeschreibung definiert sein.</p> <p>Fichier; une série d'enregistrements S-57 compilée pour un usage donné; le contenu et la structure doivent être définis par une spécification de produit.</p> <p>File; een overeenstemmende set van S-57 gegevens, samengesteld voor een speciaal doel; Inhoud en opbouw moeten door een productbeschrijving gedefinieerd worden.</p>	1
Geometric primitive	<p>One of three basic geometric units of representation: point, line and area.</p> <p>Geometrisches Grundelement; eines der drei geometrischen Darstellungselemente: Punkt, Linie und Fläche.</p> <p>Élément géométrique de base; l'une des trois unités géométriques de représentation : point, ligne et aire.</p> <p>Geometrisch basiselement; een van de drie weergave elementen: punt, lijn en vlak.</p>	1

Term or Abbreviation	Definition	Source
	<p style="text-align: center;"><b>English</b></p> <p style="text-align: center;"><b>Deutsch</b></p> <p style="text-align: center;"><b>Français</b></p> <p style="text-align: center;"><b>Nederlands</b></p>	
Geo Object	<p>Type of feature objects containing the descriptive characteristics of a real world entity.</p> <p>Eine Art des Merkmals-Objektes; enthält beschreibende Eigenschaften der realen Welt.</p> <p>Un type d'objet caractéristique; contient les caractéristiques descriptives du monde réel.</p> <p>Een type van karakteristiek object, inhoudende het beschrijvende karakter van de werkelijkheid</p>	4.2.1
Heading	<p>The direction in which the longitudinal axis of a craft is pointed, usually expressed in degrees from north (true, magnetic or compass).</p> <p>Fahrtrichtung; Richtung in die die Längsachse eines Schiffes zeigt; üblicherweise ausgedrückt in Grad (°) abweichend von Nord (tatsächlich, magnetisch oder Kompass).</p> <p>Sens de navigation; sens dans lequel pointe l'axe longitudinal d'un bateau, généralement exprimé en degrés (°) par rapport au nord (effectif, magnétique ou du compas).</p> <p>Vaarrichtung; De richting waarin de lengte as van een schip wijst; gewoonlijk uitgedrukt in graden van de noord (Daadwerkelijk, magnetische of Kompas)</p>	2.1
Head-up display	<p>The information shown on the display (radar or ECDIS) is directed so that the vessel's heading is always pointing upward. This orientation corresponds to the visual view from the bridge in direction of the ship's heading. This orientation may require frequent rotations of the display contents. Changing the ship's course, or yawing of the vessel may render this unstabilized orientation mode unreadable.</p> <p>Kurs-Voraus-Anzeige; die Bildschirmanzeige (Radar oder ECDIS) ist so ausgerichtet, dass der Kurs des Schiffes immer nach oben zeigt. Diese Ausrichtung stimmt mit dem Ausblick von der (Schiffs-)Brücke in Kursrichtung des Schiffes überein. Diese Ausrichtung kann häufige Drehungen des Anzeigeninhaltes erfordern. Änderungen des Schiffskurses oder plötzliches Gieren können dazu führen, dass diese instabile Ausrichtungsart unlesbar wird.</p> <p>Affichage cap à l'avant; affichage à l'écran (radar ou ECDIS) orienté de façon à ce que le cap du bateau pointe toujours vers le haut de l'écran. L'orientation correspond à la vue depuis le pont (du bateau) dans le sens de navigation. Cette orientation peut nécessiter de fréquentes rotations du contenu affiché. La modification du cap ou un virage soudain peuvent rendre illisible ce mode d'orientation instable.</p> <p>Koersvoor weergave; Een beeldschermweergave (radar of ECDIS) is zo ingricht dat de koers van het schip altijd naar boven wijst. Deze orientatie stemt overeen met het uitzicht vanuit de stuurhut in de koersrichting van het schip. Deze orientatie kan frequente draaiing van het beeld vereisen. Veranderingen van de scheepskoers, of plotseling gieren kan deze instabiele orientatie onleesbaar weergeven.</p>	2.1
HO-Information	<p>Information content of the SENC originated by hydrographic offices. It consists of the ENC content and updates to it.</p> <p>Informationsinhalt von SENC hergestellt durch hydrografische Büros. Er besteht aus ENC und Aktualisierungen dazu.</p> <p>Information contenue dans le SENC et fournie par les services hydrographiques. Elle se compose des ENC et de leurs actualisations.</p> <p>Informatieinhoud van SENC vervaardigd door hydrografische bureaus. Het bestaat uit ENC en actualisering daarvan.</p>	2.1



Term or Abbreviation	Definition	Source
	<p style="text-align: center;"><b>English</b></p> <p style="text-align: center;"><b>Deutsch</b></p> <p style="text-align: center;"><b>Francais</b></p> <p style="text-align: center;"><b>Nederlands</b></p>	
IEC	<p><b>International Electrotechnical Commission:</b> An international organization which produces world standards for electrical and electronical engineering with the objective of facilitating international trade.</p> <p>Internationale Elektrotechnische Kommission; internationale Organisation, die weltweite Standards für Elektrik und Elektrotechnik zur Erleichterung des internationalen Handels herausgibt.</p> <p>Commission Electrotechnique Internationale; une organisation internationale de normalisation sur le plan mondial dans le domaine de l'électricité et de l'électrotechnique visant à faciliter le commerce international.</p> <p>Internationale elektronische commissie; Een internationale organisatie, die wereldwijd standaarden voor electriciteit en elektrotechniek voor vereenvoudiging van de internationale handel uitgeeft.</p>	2.1
IHO	<p><b>International Hydrographic Organization:</b> Coordinates the activities of national hydrographic offices; promotes standards and provides advice to developing countries in the fields of hydrographic surveying and production of nautical charts and publications.</p> <p>Internationale Hydrografische Organisation; koordiniert die Aktivitäten der nationalen hydrografischen Institutionen, verbreitet Standards und berät Entwicklungsländer auf dem Gebiet der hydrografischen Vermessung und Produktion von nautischen Karten und Veröffentlichungen.</p> <p>Organisation hydrographique internationale; coordonne les activités des institutions hydrographiques nationales, publie des standards et conseille des pays en voie de développement dans le domaine de l'étude hydrographique ainsi que de la production de cartes nautiques et de publications.</p> <p>Internationale hydrografische organisatie; coordineert de activiteiten van de nationale instituten, bevordert standaarden en geeft advies aan ontwikkelingslanden op het gebied van hydrografische metingen en productie van nautische kaarten en publicaties.</p>	2.1
(IHO-) S-52	<p>Specifications for chart content and display aspects of ECDIS.</p> <p>Beschreibung für Karteninhalt und Gesichtspunkte der Darstellung von ECDIS.</p> <p>Spécification du contenu des cartes et des aspects de visualisation ECDIS.</p> <p>Specificaties voor de kaartinhoud en de aspecten van de weergave van kaarten.</p>	2
(IHO-) S-52 App. 1	<p>Guidance on updating the Electronic Navigational Chart of the IHO.</p> <p>Leitlinie für das Aktualisieren der ENC der IHO.</p> <p>Lignes directrices pour l'actualisation des GEN de l'IHO.</p> <p>Richtlijnen voor actualisering van de ENC van de IHO</p>	2
(IHO-) S-52 App. 2	<p>Colours &amp; symbols specifications for ECDIS.</p> <p>Farb- und Symbolbeschreibungen für ECDIS.</p> <p>Description des couleurs et symboles pour ECDIS.</p> <p>Kleur- en symboolbeschrijving voor ECDIS</p>	2
(IHO-) S-57	<p>IHO Transfer standard for digital hydrographic data.</p> <p>IHO-Übertragungsstandard für digitale hydrografische Daten.</p> <p>Norme de l'OHI pour la transmission digitale de données hydrographiques.</p>	3

Term or Abbreviation	Definition	Source
	<p style="text-align: center;"><b>English</b></p> <p style="text-align: center;"><b>Deutsch</b></p> <p style="text-align: center;"><b>Français</b></p> <p style="text-align: center;"><b>Nederlands</b></p>	
	IHO overdrachtsstandaard voor de digitaler hydrografische kaarten.	
(IHO-) S-57 App. A	<p>IHO Object Catalogue.</p> <p>IHO-Objektkatalog für ECDIS.</p> <p>Catalogue d'objets de l'OHI pour le système ECDIS.</p> <p>IHO objecten catalogus</p>	3
(IHO-) S-57 App. B	<p>Product Specifications.</p> <p>Produktbeschreibung für ECDIS-Daten.</p> <p>Spécification de produit pour les données ECDIS.</p> <p>Product beschrijvingen voor ECDIS gegevens</p>	3
IMO	<p><b>International Maritime Organization:</b> Formerly called IMCO, the IMO is the specialized agency of the United Nations responsible for maritime safety and efficiency of navigation.</p> <p>Internationale Seefahrtsorganisation; früher IMCO, die IMO ist die Behörde der Vereinten Nationen, die sich mit der Sicherheit und Wirtschaftlichkeit der Navigation auf See befasst.</p> <p>Organisation Maritime Internationale; anciennement IMCO, l'IMO est l'institution spécialisée des Nations-Unies chargée de la sécurité et de la l'efficacité de la navigation maritime.</p> <p>Internationale Maritime Organisatie; vroeger IMCO; de IMO is de autoriteit van de Verenigde naties, verantwoordelijk voor de veiligheid en de efficiëntie van de navigatie ter zee.</p>	2.1
Information Mode	<p>means the use of the Inland ECDIS for information purposes only without overlaid radar image.</p> <p>Informationsmodus; Verwendung des Inland ECDIS nur für Informationszwecke ohne überlagertes Radarbild.</p> <p>Mode information; utilisation du système ECDIS intérieur limitée à l'information sans super position de l'image radar.</p> <p>Informatiemodus; Gebruik van de Inland ECDIS alleen voor informatie doeleinden zonder overlapt radarbeeld.</p>	4.1
Inland ECDIS	<p>An Electronic Chart Display and Information System for inland navigation, displaying selected information from a Inland System Electronic Navigational Chart (Inland SENC) and optionally, information from other navigation sensors.</p> <p>Binnen-ECDIS; System zur elektronischen Darstellung von Karten der Binnenschiffahrtsstraßen und damit verbundenen Informationen, das ausgewählte Informationen aus einer herstellereigenen elektronischen Binnenschiffahrtskarte (Inland SENC) und wahlweise Informationen anderer Messwertgeber des Schiffes darstellt.</p> <p>ECDIS intérieur; système de visualisation des cartes électroniques de navigation intérieure et d'information, affichant des renseignements sélectionnés d'une carte électronique de navigation intérieure fonctionnelle (SENC Intérieure) et, en option, les données fournies par d'autres capteurs de navigation.</p> <p>Binnen ECDIS; Systeem voor de elektronische weergave van binnenvaartkaarten en de daaraan verbonden informatie, die geselecteerde informatie uit een specifiek geproduceerde elektronische binnenvaartkaart (Inland SENC) en ter keuze informatie van andere navigatie sensoren weergeeft.</p>	4.1

Term or Abbreviation	Definition	Source
	<p style="text-align: center;"><b>English</b></p> <p style="text-align: center;"><b>Deutsch</b></p> <p style="text-align: center;"><b>Français</b></p> <p style="text-align: center;"><b>Nederlands</b></p>	
Inland ENC	<p>Inland Electronic Navigational Chart; The database, standardised as to content, structure and format, issued for use with Inland ECDIS. The Inland ENC complies to the IHO standards S-57 and S-52, enhanced by the additions and clarifications of this standard for Inland ECDIS. The Inland ENC contains all essential chart information and may also contain supplementary information that may be considered as helpful for navigation.</p> <p>Elektronische Binnennavigationskarte; Datenbank, standardisiert bezüglich Inhalt, Struktur und Format, die zum Gebrauch mit Inland ECDIS herausgegeben wird; entspricht den IHO-Standards S-57 und S-52 mit den Ergänzungen und Klarstellungen dieses Standards für Inland ECDIS; enthält alle wesentlichen Karteninformationen und kann auch zusätzliche Informationen, die als hilfreich für die Schifffahrt angesehen werden können, enthalten.</p> <p>Carte Electronique de Navigation intérieure; base de donnée standardisée du point de vue de son contenu, de sa structure et de son format, publiée pour une utilisation avec le système ECDIS intérieur et conforme aux standards de l'IHO S-57 et S-52 complétés par des précisions relatives au système ECDIS intérieur; comporte toutes les informations cartographiques importantes et peut contenir d'autres informations susceptibles d'être utiles à la navigation.</p> <p>Elektronische binnenvaartkaarten voor de navigatie; De databank, gestandaardiseerd met betrekking tot inhoud, structuur en format, die voor gebruik met Inland ECDIS wordt uitgegeven. Inland ENC is in overeenstemming met de IHO standaard S-57 en S-52 met de aanvullingen en verduidelijkingen van deze standaard voor Inland ECDIS. Inland ENC bevat alle essentiële kaartinformatie en kan ook andere informatie bevatten die als hulp voor de scheepvaart kan worden gezien.</p>	4.1
Inland SENC	<p>Inland System Electronic Navigational Chart; a data base resulting from the transformation of the Inland ENC by Inland ECDIS for appropriate use, updates to the Inland ENC by appropriate means and other data added by the skipper. It is this data base that is actually accessed by the Inland ECDIS for the display generation and other navigational functions. The Inland SENC may also contain information from other sources.</p> <p>Herstellerspezifische Elektronische Binnenschifffahrtskarte; Datenbank, die sich aus der Transformation von Inland ENC durch Inland ECDIS für eine geeignete Anwendung ergibt und die durch Aktualisierungen der Inland ENCs mit geeigneten Mitteln und außerdem durch Daten des Schiffsführers ergänzt ist; Datenbank, auf die tatsächlich durch Inland ECDIS für die Erzeugung der Darstellung und anderer nautischer Funktionen zugegriffen wird. Inland-SENC kann auch Informationen aus anderen Quellen enthalten.</p> <p>Carte électronique pour la navigation intérieure configurée par le fabricant; une base de données résultant de la transformation de la ENC intérieure par le système ECDIS intérieur en vue d'une utilisation appropriée et complétée par l'actualisation des CEN intérieure par des moyens appropriés et par des données ajoutées par le batelier; base de données effectivement consultée par le système ECDIS intérieur pour l'élaboration des données affichées et pour d'autres fonctions nautiques. Le SCEN intérieure peut aussi contenir des informations provenant d'autres sources.</p> <p>Specifiek elektronische binnenvaartkaarten voor de navigatie; een databank, die het resultaat is van de transformatie van Inland ENC door Inland ECDIS voor een beplaat gebruik en die door actualisering van de Inland ENC met geëigende middelen en bovendien met data van de schipper aangevuld. Deze databank wordt feitelijk gebruikt door Inland ECDIS voor de ontwikkeling van de weergave en de andere nautische functies. De SENC kan ook informatie uit andere bronnen bevatten.</p>	4.1
INT 1	<p>Description entry for object classes and attributes; reference to the legend of paper charts.</p> <p>Beschreibung des Eintrages für Objektklassen und Attribute, Legende für Papier(see)karten.</p> <p>Description de classes d'objets et d'attributs, légende pour les cartes (maritimes) imprimées.</p> <p>Beschrijving van de aantekening voor objectklassen en attributen, referentie tot de legenda van papieren kaarten.</p>	4.2.1

Term or Abbreviation	Definition	Source
	<p><b>English</b></p> <p><b>Deutsch</b></p> <p><b>Français</b></p> <p><b>Nederlands</b></p>	
Integrated display	<p>means a head-up, relative-motion picture consisting of the Inland SENC overlaid with the radar-image with matching scale, offset and orientation.</p> <p>Integrierte Darstellung; vorausorientiertes, relativ zum Schiff bewegtes Bild, bestehend aus der Inland-SENC und überlagert mit dem Radarbild mit angepasstem Maßstab, Exzentrizität und Ausrichtung.</p> <p>Visualisation intégrée; une image verticale de mobilité relative par rapport à la terre fournie par le SENC intérieur, à laquelle est superposée une image radar aux paramètres d'échelle, de distance et d'orientation adaptées.</p> <p>Geïntegreerde weergave; vooruitgeoriënteerd, relatief t.o.v. het schip bewegend beeld, bestaande uit de Inland SENC bedekt met het radarbeeld met aangepaste schaal, excentriciteit en oriëntatie.</p>	4.1
M-4	<p>Description entry for object classes and attributes; reference to the IHO-Publication M-4 (Chart Specifications of the IHO)</p> <p>Beschreibung des Eintrages für Objektklassen und Attribute, Verweis auf IHO-Publikation M-4 (Chart Specifications of the IHO)</p> <p>Description de l'entrée pour les classes d'objets et les attributs, renvoi à la publication IHO M-4 (Chart specifications of the IHO)</p> <p>Beschrijving van de aantekening voor objectklassen en attributen, referentie tot de IHO-publicatie M-4 (Chart Specifications of the IHO)</p>	2
Look-up table	<p>Look-up table</p> <p>Übersichtstafel, Nachschlagetafel</p> <p>Table de visualisation, table de recherche</p> <p>Overzichts tabel, Naslag tabel</p>	
Meta object	<p>Type of feature objects; additional area related information, e. g. survey source</p> <p>Eine Art des Merkmals-Objektes; enthält gebietsbezogene Zusatzinformationen z.B. Vermessungsgrundlage</p> <p>Un type d'objet caractéristique; contient des informations supplémentaires relatives à un secteur donné, par ex. source de références</p> <p>Type van karakteristieke objecten; aanvullende gebieds gebonden informatie, bijv. inspectie bron.</p>	4
Navigation Mode	<p>means the use of the Inland ECDIS for conning the vessel with overlaid radar image.</p> <p>Navigationsmodus; Verwendung des Inland ECDIS beim Steuern des Schiffes mit überlagertem Radarbild.</p> <p>Mode navigation; utilisation du système ECDIS intérieur durant la conduite du bateau avec super position de l'image radar.</p> <p>Navigatie modus; het gebruik van Inland ECDIS bij het sturen van het schip met overlapt radarbeeld.</p>	4.1

Term or Abbreviation	Definition	Source
	<p style="text-align: center;"><b>English</b></p> <p style="text-align: center;"><b>Deutsch</b></p> <p style="text-align: center;"><b>Français</b></p> <p style="text-align: center;"><b>Nederlands</b></p>	
Object	<p>A digital representation of all or a part of an entity by its characteristics (attributes), its geometry, and (optionally) its relationships to other features (e.g., the digital description of a light sector specifying, amongst others, sector limits, the colour of the light, the visibility range, etc., and a link to a light tower, if any).</p> <p>Digitale (Daten und Informationen in Zeichenform enthaltende) Darstellung von Gegenständen (zu Gänze oder Teile davon) mit ihren Charakteristiken (Attribute), ihrer Geometrie, und wahlweise in ihrer Beziehung zu anderen Merkmalen (z.B. verschlüsselte Beschreibung eines Leuchtfeuersektors, mit unter anderem Sektorgrenzen, Farbe des Lichts, Reichweite der Sichtbarkeit, Verbindung mit einem Leuchtturm).</p> <p>Représentation digitale (contenant des données et informations sous forme de symboles) d'objets (entiers ou partiels) avec leurs caractéristiques (attributs), leur géométrie et en option leur lien avec d'autres caractéristiques (par ex. description codée d'un secteur équipé de feux, avec notamment des limites de secteurs, la couleur du feu, la distance de visibilité et le lien avec un phare).</p> <p>Digitale (gegevens en informatie in de vorm van symbolen) presentatie van voorwerpen (geheel of gedeeltelijk) met karakteristieken (attributen), de geometrie en in relatie tot andere aspecten (bijv. digitale beschrijving van een licht sector, met onder andere sectorgrenzen, kleur van het licht, reikwijdte der zichtbaarheid en een verbinding met de vuurtoren)</p>	2
Object catalogue	<p>The comprehensive list of currently identified object classes (including cartographic objects and composite objects), their appropriate attributes and the full range of allowable attribute values. It can be compared to the Chart 1 (INT 1) as the legend of the paper chart, a collection of allowed hydrographic object classes.</p> <p>Zusammenfassung aller IHO-Objektklassen (einschließlich kartografischer und zusammengesetzter Objekte) mit zugelassenen Eigenschaften und Eigenschaftswerten; der Objektkatalog entspricht der Karte 1 für die Seeschiffahrtsstraßen (INT 1) und enthält zusätzlich die speziellen Objekte für die Binnenschiffahrt.</p> <p>Liste complète de toutes les classes d'objets de l'IHO (y compris les objets cartographiques et composites) avec des caractéristiques ou valeurs de caractéristiques autorisées; le catalogue d'objets intérieur correspond à la carte 1 pour les voies de navigation maritime (INT 1) et comporte en outre des objets spécifiques à la navigation intérieure.</p> <p>Samenvatting van alle IHO-objectenklassen (inclusief kartografische en samengestelde objecten) met toegepaste eigenschappen en de volle reeks van toegelaten attribuut waarden. Het kann worden vergeleken met kaart 1 (INT 1) als de legenda voor de papieren kaart, een collectie van toegelaten hydrografische objectklassen.</p>	4.2
Object class	<p>A defined group of entities to be considered equivalent to each other, e.g. the light-vessels.</p> <p>Definierte Gruppe von Einheiten, die als gleichwertig angesehen werden können, z.B. Feuerschiffe.</p> <p>Groupe défini d'unités pouvant être considérées comme étant équivalentes les unes par rapport aux autres, par exemple les bateaux-feu.</p> <p>Een gedefinieerde groep van eenheden, die als gelijkwaardig beschouwd kunnen worden, bijv lichtschepen.</p>	2

Term or Abbreviation	Definition	Source
	<p style="text-align: center;"><b>English</b></p> <p style="text-align: center;"><b>Deutsch</b></p> <p style="text-align: center;"><b>Français</b></p> <p style="text-align: center;"><b>Nederlands</b></p>	
Object class copied	<p>S-57 object classes (with their complete set of attributes) which were extended according to the requirements of Inland ECDIS. All new object classes have the same name like their source, but are written in small case letters.</p> <p>Kopierte Objektklasse; S-57 Objektklassen (mit ihrem kompletten Satz von Attributen) erweitert gemäß der Anforderungen von Inland ECDIS. Alle neuen Objektklassen haben den gleichen Namen wie ihr Ursprung, allerdings in Kleinbuchstaben geschrieben.</p> <p>Classe d'objet copiée; classe d'objet S-57 (avec la liste complète des valeurs d'attributs) étendu conformément aux exigences du système ECDIS intérieur. Toutes les nouvelles classes d'objets portent le nom de l'attribut d'origine, mais écrit en minuscules.</p> <p>Gekopiëerde objectklasse: S 57 objectklasse (met de totale set attributen) uitgebreid overeenkomstig de vereisten van Inland ECDIS. Alle nieuwe objectklassen hebben dezelfde naam als haar oorsprong, maar klein geschreven.</p>	4.2.1
Other navigational information	<p>Navigational Information not contained in the SENC, that may be displayed by an ECDIS, such a radar information.</p> <p>Nautische Information, die nicht in der SENC enthalten ist, aber durch ECDIS angezeigt werden kann, wie Radarinformation.</p> <p>Information nautique non contenue dans le SENC mais pouvant être affichée par le système ECDIS, par exemple l'information radar.</p> <p>Nautische informatie, die niet in de SENC is opgenomen, maar door ECDIS kann worden weergegeven, zoals radarinformatie.</p>	2
Overscale	<p>Displaying data at a larger scale than it was compiled for.</p> <p>Datenanzeige in einem größeren Maßstab als ursprünglich bei der Herstellung benutzt.</p> <p>Affichage de données à une échelle supérieure à celle retenue lors de la réalisation.</p> <p>Gegevens weergave in een grotere schaal dan waarvoor het was gemaakt</p>	2
Own-ship	<p>The term which identifies the vessel upon which an ECDIS is operating.</p> <p>Eigenes Schiff; Begriff für das Schiff auf dem man sich gerade befindet und auf dem ECDIS ausgeführt wird.</p> <p>Bateau porteur; désigne le bateau sur lequel se trouve l'opérateur et à bord duquel le système ECDIS est en cours d'utilisation.</p> <p>Eigen schip; de term die het schip identificeert waarop man zich bevindt en waarop de ECDIS werkzaam is.</p>	2

Term or Abbreviation	Definition	Source
	<p style="text-align: center;"><b>English</b></p> <p style="text-align: center;"><b>Deutsch</b></p> <p style="text-align: center;"><b>Français</b></p> <p style="text-align: center;"><b>Nederlands</b></p>	
Own ship's safety contour	<p>The contour related to the own ship selected by the ship's master out of the contours provided for in the SENC, to be used by ECDIS to distinguish on the display between the safe and the unsafe water, and for generating anti-grounding alarms.</p> <p>Schiffseigene Sicherheitskontur, Sicherheitstiefenlinie; die Tiefenlinie, die der Schiffsführer im Hinblick auf den Tiefgang des eigenen Schiffes aus den Tiefenlinien ausgewählt hat, die in der SENC enthalten sind; verwendet, um in ECDIS auf der Anzeige zwischen sicherem und unsicherem Fahrwasser unterscheiden zu können und zum Erzeugen von Fehltiefen-Alarmen.</p> <p>Contours de sécurité du bateau porteur, ligne de profondeur de sécurité; la ligne de profondeur sélectionnée par le conducteur en fonction de l'enfoncement de son propre bateau parmi les lignes de profondeur disponibles dans le SENC; utilisé afin de faire la distinction dans le système ECDIS entre les eaux sûres ou présentant un risque et pour la génération d'alarmes en présence de hauts-fonds.</p> <p>Veiligheidscontour van het eigen schip, veiligheids dieptelij, de dieptelij, die de schipper met het oog op de diepgang van het eigen schip, uit de dieptelijnen in de SENC heeft gekozen, om te worden gebruikt in ECDIS om bij de weergave veilig en onveilig vaarwater te kunnen onderscheiden en om alarmen te genereren te oorkoming van aan de grondlopen.</p>	2
Performance standard	<p>Standard developed under the authority of IMO to describe the minimum performance requirements for navigational devices and other fittings required by the SOLAS Convention.</p> <p>Leistungsstandard; unter Federführung der IMO entwickelter Standard zur Beschreibung der Mindestleistungsanforderungen für Navigationsgeräte und andere Ausrüstungen laut Anforderung aus der SOLAS-Vereinbarung.</p> <p>Standard de performances; standard élaboré dans le cadre de l'IMO pour décrire les exigences minimales relatives aux performances pour les appareils de navigation et d'autres équipements conformément aux exigences de la convention SOLAS.</p> <p>Prestatiestandaard; standaard ontwikkeld onder de bevoegdheid van de IMO ter beschrijving van de minimum prestatie vereisten voor navigatieapparatuur en andere uitrustingen overeenkomstig de SOLAS conventie.</p>	2
Pick report (Object report)	<p>Short information; a window in which additional information regarding the clicked-on objects of the ENC is shown.</p> <p>Kurzinformation, Objektbericht; Fenster, in dem ergänzende Informationen zu den jeweils angeklickten Objekten der ENCs angezeigt werden.</p> <p>Information succincte, rapport d'objet; fenêtre dans laquelle sont affichées des informations complémentaires relatives aux objets représentés sur les ENC après activation par le pointeur.</p> <p>Pick rapport, object rapport; korte informatie; een venster waarin aanvullende informatie voor de aangeklikte objecten van de ENC wordt weergegeven.</p>	

Term or Abbreviation	Definition	Source
	<p><b>English</b></p> <p><b>Deutsch</b></p> <p><b>Français</b></p> <p><b>Nederlands</b></p>	
Presentation library	<p>A set of mostly digital specifications, composed of symbol libraries, colour schemes, look-up tables and rules, linking every object class and attribute of the SENC to the appropriate presentation of the ECDIS display. Published by IHO as Appendix 2 of its Special Publication 52 (S-52).</p> <p>Darstellungsbibliothek; Satz von meist in Zeichen und Zahlen verschlüsselten Anforderungen, zusammengestellt aus Symbolbibliotheken, Farbschemata, Nachschlagetafeln und Regeln, der jede Objektklasse und jedes Attribut der SENC zu einer nach IHO-S-57, Anhang 2 geeigneten Darstellung in der ECDIS-Anzeige verkettet.</p> <p>Bibliothèque des représentations; série d'exigences généralement codées en signes et en lettres, composées à partir de bibliothèques de symboles, de schémas de couleurs, de tables de recherche et de règles, associant chaque classe d'objets et attribut du SCEN à une représentation appropriée affichée par le système ECDIS conformément à l'appendice 2 au document S-57 de l'IHO.</p> <p>Weergave bibliotheek; een set van digitale specificaties, samengesteld uit symboolbibliotheken, kleurenschema's, naslagtabellen en regels, die elke objectenklasse en elk attribuut van de SENC voor de geeignende weergave van het ECDIS systeem, gepubliceerd door de IHO als appendix 2, S 52</p>	2
Product specification	<p>A defined subset of the entire specification combined with rules, tailored to the intended usage of the transfer data.</p> <p>Produktbeschreibung; definierter Teil einer vollständigen Beschreibung verbunden mit Vorschriften/Regeln und zugeschnitten auf die beabsichtigte Datenübertragung.</p> <p>Description de produit; partie définie d'une spécification complète associée à des prescriptions/règles et adaptée au transfert de données prévu.</p> <p>Produktbeschrijving; gedefinieerde deel van een volledige beschrijving verbonden met voorschriften/regels en toegesneden op de beoogde gegevens overdracht.</p>	1
Range	<p>Sequential switchable distance of a radar.</p> <p>Sequentiell schaltbarer Entfernungsbereich bei Radaranlagen.</p> <p>Portée commutable de manière séquentielle sur les appareils radar.</p> <p>Sequentieel schakelbare afstand bij een radarinstallatie</p>	5
Reference INT 1	<p>The reference to the legend of the paper chart at the classification of the object class/of the attribute.</p> <p>Referenz auf die Legende der Papierkarte bei der Beschreibung der Objektklasse/des Attributs.</p> <p>Référence à la légende de la carte imprimée lors de la description de la classe d'objet/de l'attribut.</p> <p>Referentie tot de legenda van de papierkaart bij de beschrijving van de objectklasse/ van de attributen</p>	3
Reference M-4	<p>The reference to the legend of the IHO-Publication M-4 (Chart Specifications of the IHO) at the classification of the object class/of the attribute.</p> <p>Referenz auf die IHO-Publication M-4 (Chart Specifications of the IHO) bei der Beschreibung der Objektklasse/des Attributs.</p> <p>Référence à la publication IHO M-4 (Chart specifications of the IHO) pour la description de la classe d'objet/de l'attribut.</p> <p>Referentie tot te legenda van de IHO publicatie M-4 (kaart specificatie van de IHO) bij de beschrijving van de objectklasse/ van de attributen.</p>	3



Term or Abbreviation	Definition	Source
	<p style="text-align: center;"><b>English</b></p> <p style="text-align: center;"><b>Deutsch</b></p> <p style="text-align: center;"><b>Français</b></p> <p style="text-align: center;"><b>Nederlands</b></p>	
Relative motion display	<p>A relative motion display shows the chart information, and radar targets, moving relative to the vessel position fixed on the screen.</p> <p>Anzeige der relativen Bewegung; zeigt Karteninformation und Radarobjekte in relativer Bewegung zur Schiffsposition, die auf dem Bildschirm fixiert ist.</p> <p>Affichage du mouvement relatif; affiche à l'écran en mouvement relatif des informations cartographiques et des objets détectés par le radar par rapport à la position du bateau présentée à l'écran.</p> <p>Weergave van de relatieve beweging; toont kaartinformatie en radarobjecten in relatieve beweging tot de scheepspositie, dat op het beeld is vastgelegd.</p>	2
Route monitoring	<p>The operational navigational ECDIS function in which the chart information is displayed, under control of the positioning sensor input, according to the vessel's present position (either in true motion or relative motion mode).</p> <p>Fahrtroutenüberwachung; operationelle ECDIS-Navigationsfunktion bei der die Karteninformation unter Kontrolle der Positionsangabe entsprechend der momentanen Schiffsposition (entweder in tatsächlicher oder relativer Bewegung) angezeigt wird.</p> <p>Surveillance de l'itinéraire; fonction de navigation opérationnelle du système ECDIS avec laquelle l'information cartographique est affichée avec un contrôle de la position déterminée par rapport à la position actuelle du bateau (en mouvement réel ou relatif).</p> <p>Route monitoring; de operationele ECDIS navigatiefunctie waarbij de kaart informatie, onder controle van de positie weergave overeenkomstig de huidige scheepspositie (of in werkelijke beweging danwel relatieve beweging) wordt weergegeven.</p>	1
Route planning	<p>An ECDIS function in which the area is displayed which is needed to study the intended route, to select the intended track, and to mark the track, its way points and navigational notes.</p> <p>Fahrtroutenplanung; ECDIS-Funktion, in der das Gebiet angezeigt wird, was benötigt wird um die vorgesehene Route zu studieren, die vorgesehene Fahrspur auszuwählen und zu markieren, ihre Meilensteine (Brechpunkte) und navigatorisch bedeutsame Bemerkungen.</p> <p>Planification de l'itinéraire; une fonction ECDIS affichant le secteur requis pour l'étude de l'itinéraire, le choix du chenal et pour le marquage de la route, de ses repères et d'observations nautiques utiles.</p> <p>Route planning; een ECDIS functie waarin het gebied weergegeven wordt, dat nodig is om de geplande route te bestuderen, de geplande koers te kiezen en de way-points en de bemerkingen voor de navigatie te markeren.</p>	1
SCAMIN	<p>The minimum scale at which the object may be used e.g. for ECDIS presentation.</p> <p>Der kleinste Maßstab, in dem ein Objekt in ECDIS angezeigt werden darf.</p> <p>La plus petite échelle avec laquelle l'affichage d'un objet est autorisé dans une représentation ECDIS.</p> <p>De kleinste schaal waarin een object in ECDIS aangegeven mag worden.</p>	

Term or Abbreviation	Definition	Source
	<p style="text-align: center;"><b>English</b></p> <p style="text-align: center;"><b>Deutsch</b></p> <p style="text-align: center;"><b>Français</b></p> <p style="text-align: center;"><b>Nederlands</b></p>	
SENC	<p><b>System Electronic Navigational Chart</b>; a data base resulting from the transformation of the ENC by ECDIS for appropriate use, updates to the ENC by appropriate means and other data added by the mariner. It is this data base that is actually accessed by the ECDIS for the display generation and other navigational functions. The SENC may also contain information from other sources.</p> <p>Herstellerspezifische Elektronische Schifffahrtskarte; Datenbank, die sich aus der Transformation von ENC durch ECDIS für eine geeignete Anwendung ergibt und die durch Aktualisierungen der ENCs mit geeigneten Mitteln und außerdem durch Daten des Schiffsführers ergänzt ist; Datenbank, auf die tatsächlich durch ECDIS für die Erzeugung der Darstellung und anderer nautischer Funktionen zugegriffen wird. SENC kann auch Informationen aus anderen Quellen enthalten.</p> <p>Carte électronique pour la navigation intérieure fonctionnelle ; une base de données résultant de la transformation de la ENC par le système ECDIS intérieur pour un usage rationnel, de la mise à jour de la ENC intérieure par des moyens appropriés et de l'adjonction d'autres données par le batelier. C'est à cette base de données que le système ECDIS intérieur accède en fait pour engendrer l'image et pour d'autres fonctions de navigation. La SENC intérieure peut également contenir des renseignements émanant d'autres sources.</p> <p>Door de fabrikant vervaardigde elektronische kaart voor de binnenvaart. Databank die is gebaseerd op de vertaling van ENC naar ECDIS voor toegepast gebruik en die door actualisering van ENC en bovendien door gegevens van schippers vervolmaakt is. Juist deze informatie wordt gebruikt door ECDIS voor ontwikkeling, presentatie en voor andere nautische functionaliteiten. De SENC kan ook onderdelen uit andere informatiebronnen bevatten".</p>	4.1
Spatial object	<p>An object which contains locational information about real world entities.</p> <p>Räumliches Objekt; Objekt, das örtliche Informationen über reale Einheiten enthält.</p> <p>Objet de localisation; un objet contenant les informations locales relatives à des unités réelles.</p> <p>Ruimtelijk object; een object dat plaatselijke informatie over de werkelijkheid bevat.</p>	1
Set_Attribute A:	<p>A subset; the individual characteristics of the object.</p> <p>Attributgruppe A; individuelle Eigenschaften eines Objekts.</p> <p>Groupe d'attributs A; caractéristiques individuelles d'un objet.</p> <p>Attribuut set A; individuele eigenschappen van een object.</p>	4.2.1
Set_Attribute B:	<p>A subset; the information of the use of an object.</p> <p>Attributgruppe B; Information über den Gebrauch eines Objekts.</p> <p>Groupe d'attributs B; Information relative à l'utilisation d'un objet.</p> <p>Attribuut set B; informatie over het gebruik van de objecten.</p>	4.2.1
Set_Attribute C:	<p>A subset; the information about the administration on the origin of data.</p> <p>Attributgruppe C; administrative Informationen über die Herkunft der Daten.</p> <p>Groupe d'attributs C; Informations administratives relatives à la source des données.</p> <p>Attribuut set C; administratieve informatie over de herkomst van de gegevens.</p>	4.2.1

Term or Abbreviation	Definition	Source
	<p style="text-align: center;"><b>English</b></p> <p style="text-align: center;"><b>Deutsch</b></p> <p style="text-align: center;"><b>Français</b></p> <p style="text-align: center;"><b>Nederlands</b></p>	
Standard display	<p>Standard Information Density means the default amount of SENC information that shall be visible when a chart is first displayed on ECDIS first.</p> <p>Standardanzeige, bedeutet den Standardumfang an SENC-Informationen, der zuerst sichtbar sein muss, wenn die Karte in ECDIS angezeigt wird.</p> <p>Affichage standard; désigne la densité standard des informations du SENC devant être visibles en premier lors de l'affichage de la carte par le système ECDIS.</p> <p>Standaard weergave, betekent de omvang van de standaard van SENC informatie, die pas zichtbaar moet zijn wanneer de kaart in ECDIS wordt weergegeven.</p>	1
SOLAS	<p>International Convention for the <b>Safety of Life at Sea</b> developed by IMO. The contracting governments undertake to promulgate all laws, decrees, orders and regulations and to take all other steps which may be necessary to give the present convention full and complete effect, so as to ensure that, from the point of view of safety of life, a ship is fit for the service for which it is intended (Article 1b of SOLAS).</p> <p>Internationales Abkommen über die Sicherheit des Lebens auf See, entwickelt durch die IMO. Die Unterzeichnerstaaten verpflichten sich, alle Gesetze, Verordnungen, Ausführungsbestimmungen und sonstige Vorschriften zu erlassen und alle sonstigen Maßnahmen zu treffen, die erforderlich sind, um diesem Übereinkommen volle Wirksamkeit zu verleihen und dadurch zu gewährleisten, dass sich im Hinblick auf den Schutz des menschlichen Lebens ein Schiff für seinen Verwendungszweck eignet (Artikel 1b der SOLAS).</p> <p>Convention internationale pour la sauvegarde de la vie humaine en mer, élaborée par l'IMO. Les Etats contractants s'engagent à promulguer toutes lois, tous décrets, ordres et règlements et à prendre toutes autres mesures nécessaires pour donner à la Convention son plein et entier effet, afin de garantir que, du point de vue de la sauvegarde de la vie humaine, un navire est apte au service auquel il est destiné.</p> <p>Internationale conventie van Safety of life at Sea ontwikkeld door de IMO. De verdragsstaten verplichten zich alle wetten, verordeningen, uitvoeringsregelingen en overige voorschriften uit te vaardigen en alle overige maatregelen te treffen, die noodzakelijk zijn om deze overeenkomst volledig werkzaam te laten zijn en daardoor te verzekeren, dat met het oog op de bescherming van de mens een schip voor zijn doel geschikt is (Artikel 1b van SOLAS).</p>	2.1
User-defined settings	<p>Means the possibility to use and store a profile of display and operation controls-settings.</p> <p>Benutzerdefinierte Einstellungen; Möglichkeit, ein Profil von Anzeige- und Betriebseinstellungen zu verwenden und zu speichern.</p> <p>Configuration par l'utilisateur; la possibilité d'utiliser et d'enregistrer une configuration donnée pour les paramètres d'affichage et de fonctionnement.</p> <p>Voor de gebruiker gedefinieerde instellingen; betekent de mogelijkheid om een profiel van weergave en gebruiksinstellingen te gebruiken en vast te leggen.</p>	4.1
Vector	<p>Spatial information whose data model is based on graph theory.</p> <p>Räumliche Information deren Datenmodell sich auf eine Graphentheorie begründet.</p> <p>Information spatiale dont le modèle de données s'appuie sur une théorie graphique.</p> <p>Ruimtelijke informatie waarvan het gegevens model is gebaseerd op de grafische theorie.</p>	1
VRM	<p><b>Variable Range Marker.</b></p> <p>Variabler Entfernungsmessring.</p> <p>Cercle variable de mesure des distances.</p> <p>Variabele afstandsmeting</p>	5

Term or Abbreviation	Definition	Source
	<p style="text-align: center;"><b>English</b></p> <p style="text-align: center;"><b>Deutsch</b></p> <p style="text-align: center;"><b>Français</b></p> <p style="text-align: center;"><b>Nederlands</b></p>	
WGS 84	<p><b>WORLD GEODETIC SYSTEM:</b> A global geodetic reference system developed by the USA for satellite position fixing and recommended by IHO for hydrographic and cartographic use.</p> <p>Weltweites Geodätisches System; von den USA entwickeltes globales geodätisches Referenzsystem für Satellitenpositionsbestimmung, von der IHO empfohlen für den hydrografischen und kartografischen Gebrauch.</p> <p>Système géodésique mondial; un système global de référence géodésique développé par les USA pour le positionnement par satellite, recommandé par l'IHO pour un usage hydrographique et cartographique.</p> <p>Wereldwijd geodatisch systeem; een door de USA ontwikkeld wereldomvattend geodatisch referentiesysteem voor sateliet positie bepaling, aanbevolen door de IHO voor hydrografisch en kartografisch gebruik.</p>	2.1