



Ministry of Infrastructure
and Water Management



Schweizerische Eidgenossenschaft
Confédération suisse
Confederazione Svizzera
Confederaziun svizra

STUDY ON FINANCING THE ENERGY TRANSITION TOWARDS A ZERO-EMISSION EUROPEAN IWT SECTOR

CCNR Member States:



Study consortium:



ECORYS



Panteia
Research to Progress



In partnership with:

European Investment *Advisory Hub*
Europe's gateway to investment support

LIABILITY DISCLAIMER

The facts presented in this study and the associated deliverables, as well as the opinions expressed, are those of the authors and do not necessarily also represent the position of the Central Commission for the Navigation on the Rhine (CCNR), the Advisory Hub, the European Investment Bank or the European Commission on the subject in question. Use of the knowledge, information or data contained in this document is at the user's own risk. The CCNR shall in no way be liable for use of the knowledge, information or data contained in this document or any ensuing consequence.

October 2020



Study

**“Assessment of technologies in
view of zero-emission IWT“**

**Part of the overarching study
“Financing the energy transition to-
wards a zero-emission European IWT
sector“**

Assessment of technologies in view of zero-emission IWT

Report No. 2293
October 2020

Entwicklungszentrum für Schiffstechnik und Transportsysteme e. V.
DST – Development Centre for Ship Technology and Transport Systems

Oststr. 77
47057 Duisburg
Germany

Tel. +49 203 99369-0
Fax +49 203 99369-70
e-mail dst@dst-org.de
web www.dst-org.de



Member of the German Federation of Industrial Research Associations
(Arbeitsgemeinschaft industrieller Forschungsvereinigungen
"Otto von Guericke" e. V.)



Member of the Johannes-Rau-Forschungsgemeinschaft e. V.



Institute at the University Duisburg-Essen



Member of the International Towing Tank Conference



Member of the Center of Maritime Technologies e. V.

Imprint

Contracting Authorities: Eidgenössisches Departement für Umwelt, Verkehr,
Energie und Kommunikation
Bundesamt für Verkehr (BAV)
Abteilung Sicherheit / Sektion Schifffahrt
Mühlestraße 6
3063 ITTIGEN
SCHWEIZ

Contractor: DST – Development Centre for Ship Technology and Transport
Systems
Oststraße 77
47057 Duisburg
Tel.: +49-203 99369-0 | Fax: +49-203 99369-70
dst@dst-org.de | www.dst-org.de

Authors: Friederike Dahlke-Wallat
Benjamin Friedhoff
Sophie Martens

Copyright: Federal Authorities of the Swiss Confederation.

Copyright and any other rights relating to texts, illustrations, photographs or any other data available on the study “Assessment of technologies in view of zero-emission IWT” are the exclusive property of the Federal Office of Transport (FOT) or of any other expressly mentioned owners.

Any reproduction requires the prior written consent of the copyright holder.

All rights reserved

Table of Contents

1	INTRODUCTION	9
2	DESCRIPTION OF THE SITUATION IN 2015	12
2.1	DIVERSITY OF THE FLEET	14
2.2	OPERATIONAL PROFILES	15
2.3	RESULTS FROM THE H2020 PROMINENT PROJECT	17
3	GREENING TECHNOLOGIES	23
3.1	ENERGY CARRIERS	24
3.1.1	HYDROGEN	26
3.1.2	METHANOL	26
3.1.3	DROP-IN FUELS GTL, HVO AND PTL	28
3.1.4	BATTERY	30
3.1.5	LNG	32
3.2	EMISSION REDUCTION POTENTIAL	33
3.3	ENERGY CONVERTERS	34
3.3.1	STAGE V AND EURO VI ENGINES	34
3.3.2	GAS AND GAS-ELECTRIC PROPULSION CONCEPTS	35
3.3.3	HYDROGEN IN COMBUSTION ENGINES	39
3.3.4	BATTERY ELECTRIC DRIVES	40
3.3.5	FUEL CELL SYSTEMS	42
3.4	ENERGY EFFICIENCY	46
4	COST FIGURES AND PREDICTIONS	47
4.1	INVESTMENT	48
4.2	CAPITAL COSTS AND DEPRECIATION	50
4.3	OPERATIONAL COSTS	50
4.4	FUELS	51
4.5	MAINTENANCE	53
5	FLEET FAMILIES	54
5.1	MAIN CHARACTERISTICS OF THE FLEET FAMILIES	54
5.2	FLEET DEVELOPMENT	55
5.3	TECHNOLOGIES DIFFERENTIATED TO THE FLEET FAMILIES	56
5.3.1	EXEMPLARILY TYPE SHIPS PER FLEET FAMILY	63

6	TRANSITION PATHWAYS	85
6.1	REDUCTION OF EMISSIONS BY 35 % UNTIL 2035	85
6.2	EMISSION REDUCTION TARGET 2050	86
6.2.1	SCENARIO HVO 80 % REDUCTION	89
6.2.2	SCENARIO 80 % REDUCTION	89
6.2.3	SCENARIO HVO 90 % REDUCTION	90
6.2.4	SCENARIO 90 % REDUCTION	91
6.2.5	SCENARIO 98 % REDUCTION	92
6.2.6	SCENARIO 100 % REDUCTION	93
6.3	COSTS OF THE SCENARIOS	94
7	SUMMARY, CONCLUSIONS AND OUTLOOK	96
8	BIBLIOGRAPHY	98

List of abbreviations

AC	Alternating Current
AFOLU	Agriculture, Forestry and Other Land-Use
BTL	Biomass to Liquid
CAPEX	Investment Costs
CDNI	Convention Relative a la Collecte, au Depôt et a la Reception des Dechets Survenant en Navigation Rhenane et Intertieure (Convention on the Collection, Deposit and Reception of Waste Generated During Navigation on the Rhine and Other Inland Waterways)
DC	Direct Current
DNV GL	Det Norske Veritas
DPF	Diesel Particulate Filter
FC	Fuel Cell
GHG	Greenhouse Gas
GTL	Gas-to-Liquid
HT	High Temperature
HVO	Hydrotreated Vegetable Oil
ICE	Internal Combustion Engine
IWT	Inland Waterway Transport
IPCC	Intergovernmental Panel on Climate Change
LCO	Lithium Cobalt Oxide
LFP	Lithium Iron Phosphate
LMO	Lithium Manganese Oxide
LNG	Liquefied Natural Gas
LTO	Lithium Titanate Oxide Anode
LT	Low Temperature
NCA	Lithium Nickel Cobalt Aluminium Oxide
NCM	Lithium Nickel Cobalt Manganese Oxide
OEM	Original Equipment Manufacturer
OPEX	Operational Costs
PEM FC	Proton Exchange Membrane Fuel Cell
PM	Particulate Matters
PTL	Power to Liquid
PTX	Power to X
RED II	Renewable Energy Directive

ROI	Return on Investment
RPM	Revolutions per Minute
SCR	Selective Catalytic Reduction
SULEV	Super Ultra-Low Emissions Vehicle
TCS	Tank Connection Space
TCO	Total Cost of Ownership
TRL	Technological Readiness Level
TtW	Tank to Wake
US EPA	United States Environmental Protection Agency
VDMA	Verband Deutscher Maschinen- und Anlagenbau (German Mechanical Engineering Industry Association)
WEO	World Energy Outlook
XTL	X to Liquid

1 Introduction

Against the background of the expected climate change and the requirements of society as regards a clean and green transport, also for Inland Waterway Transport (IWT) a greening of the fleet, i.e. a transition towards zero-emissions is desired. Concretely, greenhouse gas and air pollutant emissions shall be reduced by 35 % (compared to 2015) until 2035 and almost completely eliminated until 2050. Given the since many decades (almost a century) established, reliable and proven diesel technology and the long life-cycles of inland vessels this claim constitutes an extraordinary challenge. If combustion engines are ruled out it requires nothing less than a complete transformation of the whole propulsion technology (drive system) of the European IWT-fleet and hence a complete system change. It's within its nature, that a step of such dimension requires deep and sound preparations as well as time.

Much of the necessary information needed for such decisions and assessments, e.g. as regards the technologies themselves, their impacts, and costs, especially for future scenarios, are presently not available or incomplete. Therefore, it is self-evident, that the investigations reported herein can only provide a first, preliminary step of the intended transformation process which has to be continuously further developed within the next years and decades based on the prospectively available energy sources and technological developments and related costs. In the light of the mentioned requirements and frame conditions the investigations cannot provide ultimate and final assessments. They rather provide well-grounded and justified estimations based on available knowledge and information.

The advantages of ships in transport are well known. Based on hydrostatic buoyancy, large masses can be moved slowly but with very modest power. While maritime transport is almost without alternative for large quantities of goods, inland navigation competes with rail and road transport. The low infrastructure costs and emissions contribute to the reputation of inland navigation as a gentle mode of transport. The high energy efficiency, which is expressed e.g. in the energy requirement per tonne-kilometre, is also accompanied by low CO₂ emissions.

At the same time, inland navigation vessels are extremely durable. This special feature is generally assessed positively in a life cycle analysis or ecological efficiency analysis. However, this also leads to the conclusion that the renewal rate of the engines is low, which in turn results in disproportionately high emissions of nitrogen oxides and particulate matter. Although the engines are renewed during the course of a ship's life, with cycles of typically 15 to 20 years, they are renewed less frequently than in road transportation. Older engines have even longer service lives. As a result, a large majority of inland waterway vessels do not operate with the latest engine technology and without exhaust after-treatment systems. The small quantities of marine engines lead to longer product cycles and thus additionally to a delayed spread of new technologies.

Considerable efforts are required to maintain the position as the most environmentally friendly mode of transport in the long term. Since the beginning of 2019 (2020 for engines with 300 kW or more output), stricter exhaust emission limits apply to new inland waterway engines placed on the market in accordance with Regulation (EU) 2016/1628, which, at least for large engines, are only achieved with particulate filters and SCR-systems. SCR stands for selective catalytic reduction. In this process, nitrogen oxides are converted into water vapour and nitrogen in special catalytic converters with the addition of an aqueous urea solution. Proof of compliance with these Stage V limits requires a dedicated type approval for engines, which is not only time-consuming but also costly in view of the small market. In addition, the type approval includes the specification of the fuel. Therefore, it is important to consider the (future) use of non-fossil drop-in fuels like HVO and PTL, which can be used as blends or pure fuels, as soon as possible. Drop-in fuels are a synthetic and widely interchangeable substitute for conventional petroleum-derived hydrocarbons as further described in 3.1.5. Especially GTL (Gas-to-Liquid) and HVO (Hydrotreated Vegetable Oil) standardized by EN 15940 are considered important for inland navigation among the synthetic fuels.

Compared to other modes of transport, inland shipping still has considerable capacity reserves for additional transport performance on most waterways, which makes the desired shift of freight traffic to relieve the roads possible. At the same time, there is a high inter- and intramodal cost pressure. Measures to improve the environmental compatibility of inland navigation must therefore be developed and implemented in a complex field of tension. Essential boundary conditions are the consideration of the existing fleet and economic efficiency. The many small entrepreneurs, who operate the majority of the fleet as private owners and suffer from the lack of available credit, could not comply with excessively strict legislation, so that the desired modal shift would be jeopardised. Nor is it possible to modernise the fleet with public money alone. Thus, the sustainable improvement of emissions requires a careful analysis of the overall situation and a multitude of initiatives and solutions. Almost every ship is different from a technical point of view. The differences are based on the respective transport task of the ship and the boundary conditions under which the transport service is to be provided. As a result of the diversity of the fleet, very different measures can be target-oriented.

In the following chapters, the energy carriers and technologies for the corresponding energy conversion are first presented and analysed with regard to their suitability for inland navigation. The focus is put on a set of technologies with high technological readiness, which was agreed upon between the CCNR, the Swiss delegation and DST. Technologies like battery cell types with higher energy density, ammonia as an energy carrier for combustion engines or fuel cells and more exotic solutions are being researched and developed. They might contribute to the energy transition in IWT at a later stage. However, they are not considered mature enough to be used for the cost predictions at this time. Further on, the fleet structure and the boundary conditions of inland navigation are presented. Due to the limited energy density and the -at least in the medium term- weakly developed infrastructure of alternative energy carriers, the importance of the operational profiles is also discussed. Afterwards, the cost figures for investment and operation today and forecasted for the next 30 years are discussed. The fleet families defined in the H2020 project PROMINENT are expanded slightly and the

technologies are assessed for these ship types. For each of them a possible zero-emission system and the related investment and operational costs are described. Afterwards, several exemplary chains of measures for each segment of the fleet were iteratively chosen to meet the emission reduction goals by 2035 and 2050.

The Mannheim Declaration clearly specifies the 35 % reduction target for air pollutants and CO₂ emissions by 2035 compared to 2015. For 2050 the target to “largely eliminate greenhouse gases and other pollutants” leaves more room for interpretations. Therefore, for 2050 the costs are estimated for chains of measures with different ambition levels, i.e. proportions of more or less advanced technologies. While this study was finalized, the ambition was made concrete to an “emission reduction of at least 90 %”.

Putting the focus on air pollutants, emissions can largely be reduced by a fleet modernisation with modern combustion engines with exhaust gas aftertreatment. In case climate-neutrality is aimed at, the complexity of measures and evaluation criteria increases. There is a broad consensus that the use of fossil fuels should be avoided in the long term. However, the possible role of biofuels is under discussion. With second generation biofuels like HVO used in combustion engines with aftertreatment, the local emissions of CO₂ and air pollutants are almost the same as with fossil diesel. Nevertheless, biofuels are considered carbon-neutral as the amount of carbon dioxide that is absorbed by the feedstock plants during the next growing season is equal to the carbon dioxide that is released during the combustion process as per IPCC (Volume 4, Chapter 5, 5.2.4 Non-CO₂ greenhouse gas emissions from biomass burning [1]). The source of these biofuels is similar to that of fossil fuels except that the process is much faster. Usually, today the upstream chain of these fuels including production and transport are not ideal and limiting the climate-neutrality. This is also addressed in the renewable energy directive (RED II) which is not considered further in detail within the current report since so far only a tank-to-wake (TtW) perspective is used. Additionally, the quantity of sustainable feedstocks is limited, so that a global replacement of fossil fuels is not likely until 2050. Advanced zero-emission technologies like batteries and fuel cells require extensive investments for infrastructure ashore and the installations aboard while also still facing sustainability challenges in the upstream chains or at the end of lifecycles.

2 Description of the situation in 2015

The European inland waterway fleet in general is best explained by the waterway network, as the ship's size is based on the dimensions of the waterways, locks and bridges. European inland waterways have a total length of 41,500 kilometres, divided into navigable rivers and lakes and artificial canals. This transport network is divided by the European Conference of Ministers of Transport (ECMT) into seven waterway classes with additional subgroups as indicated in the table below.

Table 1: Classification of the European Inland Waterways into CEMT-Classes

Class	Motor Vessels			Pushed Convoys			Clearance height
	Length	Breadth	Depth	Length	Breadth	Depth	
	[m]	[m]	[m]	[m]	[m]	[m]	[m]
I	38.5	5.05	1.8 – 2.2				4.0
II	50 – 55	6.60	2.5				4.0 – 5.0
III	67 – 80	8.20	2.5				4.0 – 5.0
IV	80 – 85	9.50	2.5	85	9.5	2.5 – 2.8	5.25
Va	95 – 110	11.40	2.5 – 2.8	95	11.4	2.5 – 4.5	5.25
Vb				172	11.4	2.5 – 4.5	5.25
Vla				95	22.8	2.5 – 4.5	7.0
Vlb	140	15.0		185	22.8	2.5 – 4.5	7.0
Vlc				270 195	22.8 33.0	2.5 – 4.5	9.1
VII				285	33.0	2.5 – 4.5	9.1

The western European market is characterised by a relatively old fleet, which can be seen in Figure 1 provided by the CCNR secretariat (based on the IVR data base [2]).

Figure 1 shows the commissioning activity for the Rhine fleet. It should be mentioned that floating equipment is excluded from the considerations in this report.

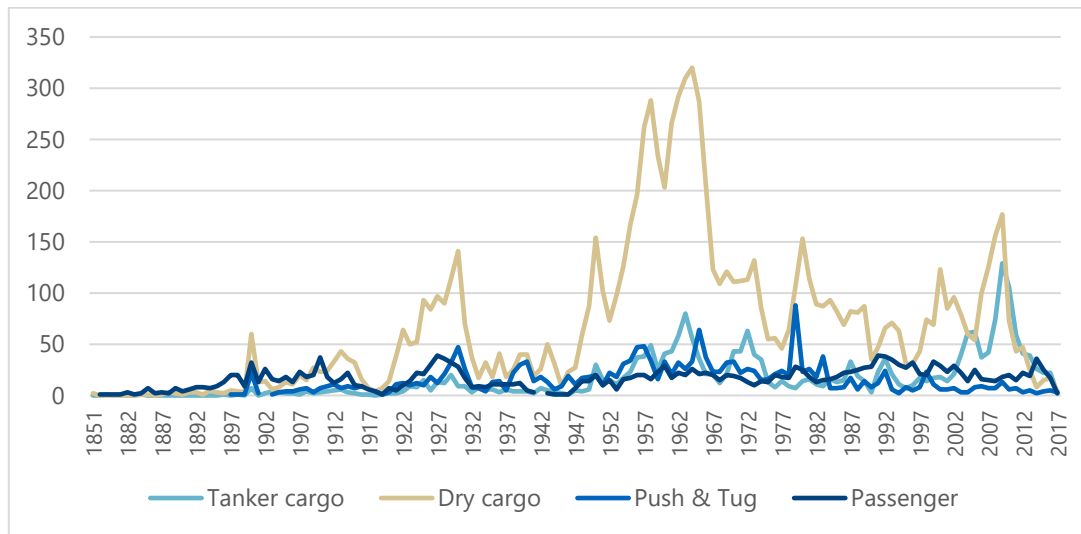

Figure 1: Commissioning activity for the Rhine fleet [2]

Figure 2 is exemplarily showing the age structure of the German fleet. Particularly older, smaller vessels are sometimes operated for more than 100 years. Therefore, retrofitting plays a significant role in IWT. In accordance with the changing transport tasks and other boundary conditions, these ships are sometimes significantly altered. Initially, dumb barges were converted to motor vessels. Today, the vessels are lengthened or even widened and converted for carrying barges in coupled convoys. The fleet is correspondingly heterogeneous in terms of ship dimensions. Considering the propulsion units, the variety once again increases significantly.

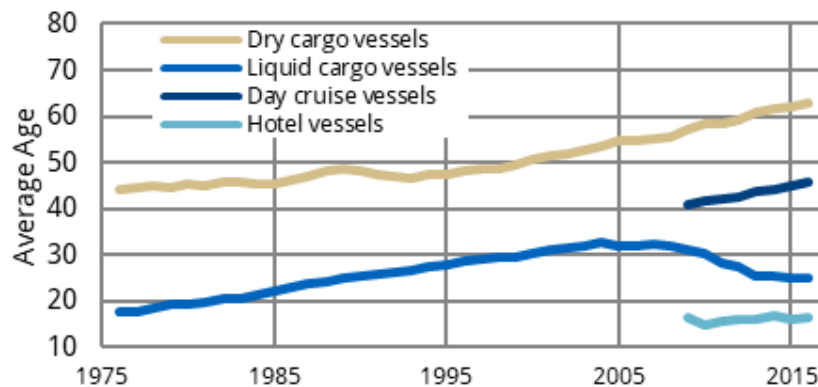

Figure 2: Age development of the German inland fleet [3]

In Figure 3 the commissioning activity for the Danube is shown (plot provided by CCNR secretariat based on the Danube Commission market observation report [4]). The Danube fleet has a high number of vessels that were built between 1960 and 1990. Since the year 2000 not many new vessels were built for the Danube.

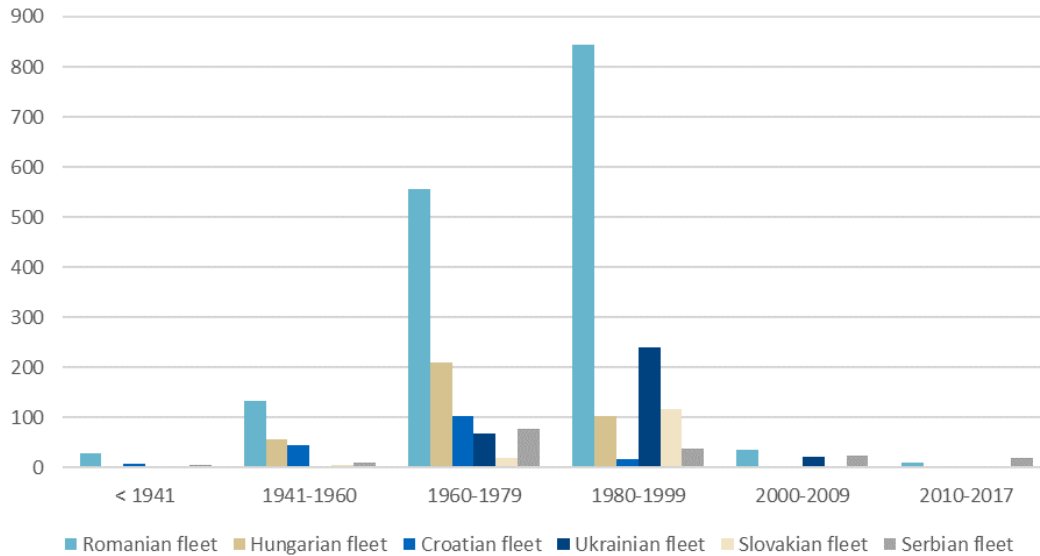

Figure 3: Number of vessels per year of construction in Danube countries [4]

2.1 Diversity of the fleet

To showcase the fleet diversity, the push boats are analysed exemplarily. The following figure shows the structure of the European fleet of push boats. It can be seen that the vessels can be classified according to the installed power, length and number of propellers installed. The wide spread of classes necessary to classify this segment of the fleet makes the diversity obvious.

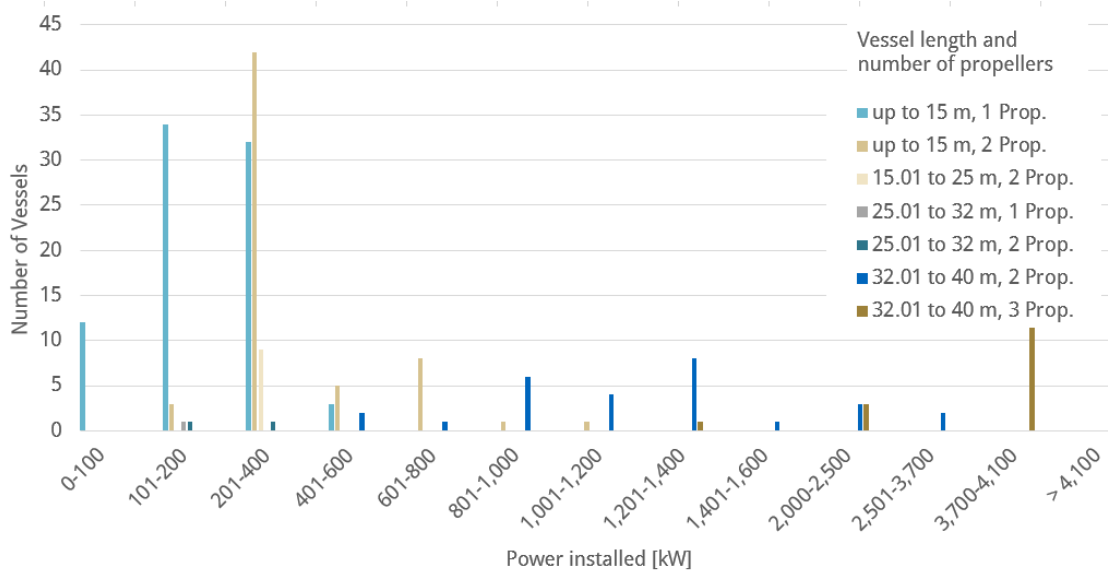

Figure 4: Installed power, number of propellers and length distribution of the European push boat fleet [2]

The different motorization suggests that the engine rooms are also designed very differently. Different numbers of propellers also mean that there are many differently designed aft sections. It can be concluded that there can be no standard solution for large parts of the fleet, but that each ship requires an individual solution.

In addition, the push boats operate in very diverse areas. Some only operate on large rivers such as the Rhine, others operate mainly in the canal network and there are fixed as well as highly variable routes that are used. This wide variety of different sailing areas and associated operational profiles also contributes to the fact that each vessel has to be equipped with a more individual propulsion solution.

The next figure shows the age structure of the push boat fleet. Here too, a wide spread can be seen.

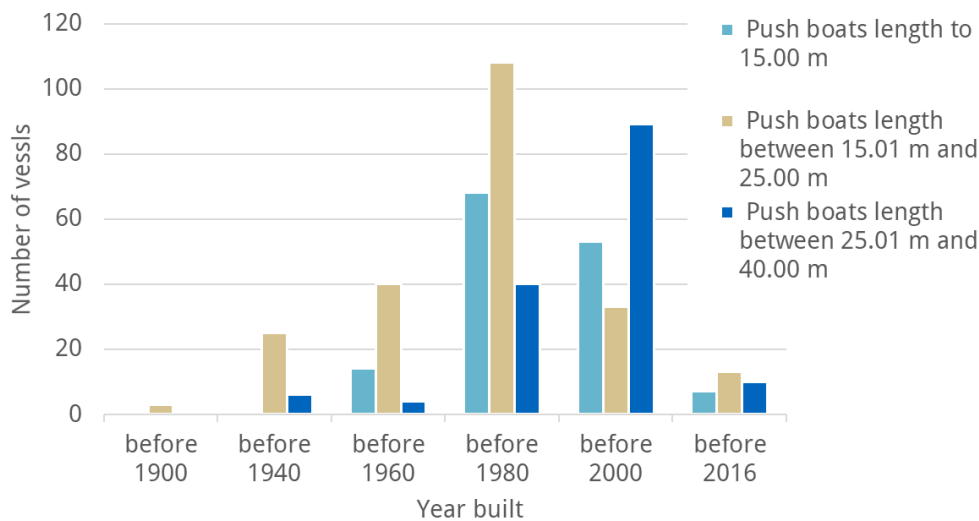

Figure 5: Age classes for European push boats [2]

The age of the vessels also has an influence on the installation options for zero-emission technologies. For example, the design of the engine room or the investment options for an older ship can be decisive.

2.2 Operational profiles

While maritime transport often operates around the clock with largely constant operating conditions of the propulsion system, the boundary conditions of inland navigation result in a complex operational profile. First of all, a distinction must be made here according to the type of operation, i.e. the maximum daily operating time of a ship depending on crew size and equipment, in accordance with the Inland Waterways Vessel Inspection Regulation or the Rhine Vessel Personnel Regulation. Then the area of operation plays an important role. While only a small part of the installed capacity is usually used in the canal network and in downstream navigation, the power requirement is for example significantly higher on the Rhine in upstream navigation. However, more recent studies within the framework of the EU project PROMINENT [5] show that, contrary to previous assumptions, less than half of the available drive power is often used when sailing against the direction of flow. Figure 6 shows operating profiles of a container ship during five up and down voyages between Antwerp and Mainz. Nevertheless, the vessels are not generally overpowered, but the power reserve can be necessary

and safety-relevant for local and rarely occurring discharge conditions or the prescribed stopping capacity.

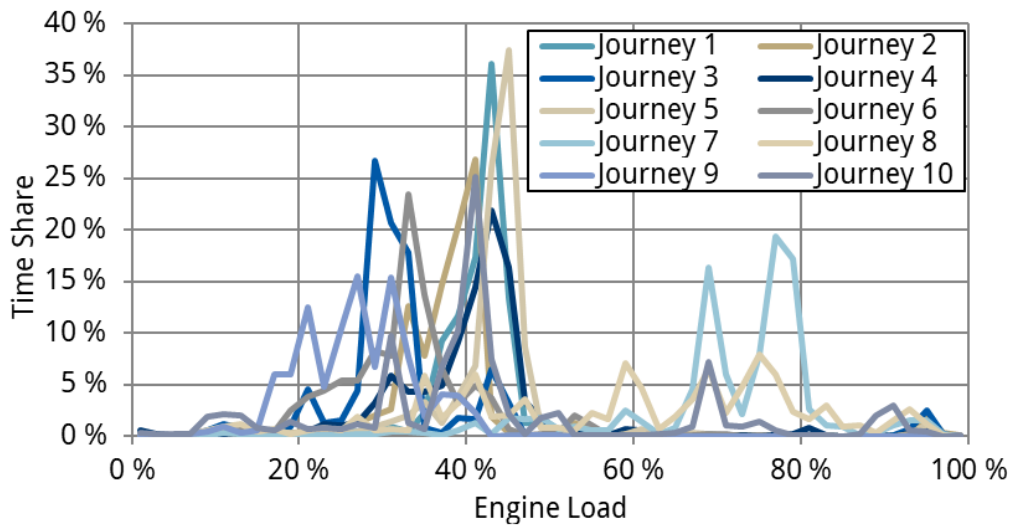

Figure 6: Operational profile of a container ship during 10 voyages in ARA-Rhine traffic [6]

Figure 7 shows the variation of water depth and current velocity at mean water level for a 70 km long segment of the Middle Rhine. The strong change in flow velocity is clearly visible. In addition, there is the skipper's way of driving, a high variability of loading cases and the fact that in inland navigation manoeuvring is virtually normal operation. Thus, even on the same route, voyages with the same ship are difficult to compare. Large differences between the temporary and average energy and power requirements are possible. However, many vessels have significant reserve power installed today. This resulted from desired longer service intervals with low utilization and the moderate costs of conventional direct drives. Facing the need to improve environmental performance and the size and costs of advanced technologies, it is expected that on average the installed power can be reduced by approximately 25 % for new drive trains. The characteristics of electric drives, e.g. with high torque of the electric motors and batteries for peak shaving, are helping in critical situations.

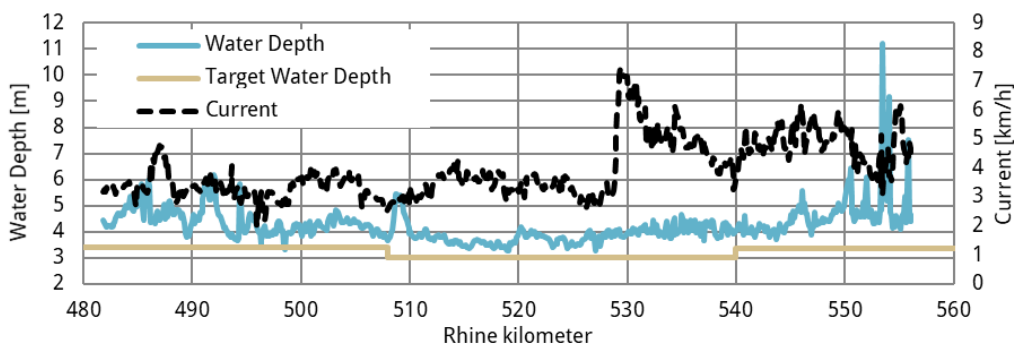

Figure 7: Environmental conditions at medium flow on a section of the Middle Rhine [6]

2.3 Results from the H2020 PROMINENT project

As proposed, the fleet families were taken from the project PROMINENT and supplemented by the fleet families “Daytrip Cruise Vessels” and “Ferries”. The fleet families in the PROMINENT project were set up according to the following scheme:

Different classification systems and data sources have been used for the definition of the fleet families in PROMINENT [5]:

*“For motor cargo vessels, the **length** has been used to classify the various vessel types.*

*The CEMT classification system has been used as a basis for the division of the smaller vessel types. The motor cargo vessels of CEMT class I, II and III (mainly **below 80 m**) are considered of regional importance and have been included into one family. No distinction is made here between dry and liquid cargo vessels.*

*For the larger and newer vessel sizes, the newer RWS classification system (RWS 2010) has been used. This classification system has grouped more or less comparable vessels into 12 classes. The most representative classes in Europe have been identified using vessel traffic counts. One of the most common vessel types used in Europe is the Large Rhine Vessel, with a reference vessel dimension of 110 metre in length and 11.4 metre in width. This length has been used to identify the lower limit of the largest vessel sizes. A distinction is made between dry and liquid cargo vessels. Therefore, all the dry cargo motor vessels **equal to or above 110 m** have been included into one family and all the liquid cargo motor vessels equal to or above 110 m have been included into another fleet family.*

*The remaining category (i.e. **vessels between 80 – 109 m**) has been included into the other fleet families for motor cargo vessels. A distinction is also made here between dry and liquid cargo vessels.*

*For push boats, the vessels have been classified based on the **total propulsion power**. According to the vessel traffic counts in Europe (see section 2.2 and 2.3), the most common push barge formations (following the RWS classification system) are:*

- *Pusher with 1 Europa II barge;*
- *Pusher with 2 Europa II barges;*
- *Pusher with 4 Europa II barges;*
- *Pusher with 6 Europa II barges.*

Pusher with 1 or 2 Europa II barges are more common on specific waterways (e.g. on the North-South corridor between the Netherlands and Belgium), whereas pusher with 4 Europa II barges or more travel on larger waterways (e.g. Rhine).

The pusher with one Europa II barge has in general a propulsion power around 500 kW. In the study by PANTEIA et al. (2013) ‘Contribution to impact assessment of measures for reducing emissions of inland navigation’ a range between 1,000 - 2,000 kW was used for a pusher with 2 Europa II barges. A total propulsion power above 2,000 kW is more common for pushers with 4 Europa II barges or more. The other smaller pushed convoys have in general a total propulsion power below 500 kW.

In this study, the push boats have been divided into the following categories:

- Push boats below 500 kW (total propulsion power);
- Push boats between 500 - 2,000 kW (total propulsion power);
- Push boats above 2,000 kW (total propulsion power).

Coupled convoys have been classified into one family as the large majority of them are class Va vessels sailing with a Europe II lighter. Passenger vessels have been classified into one family as well and include hotel and cruise vessels.”

The fleet analysis came to the following distribution of the fleet families within the European inland waterway fleet (see Figure 8):

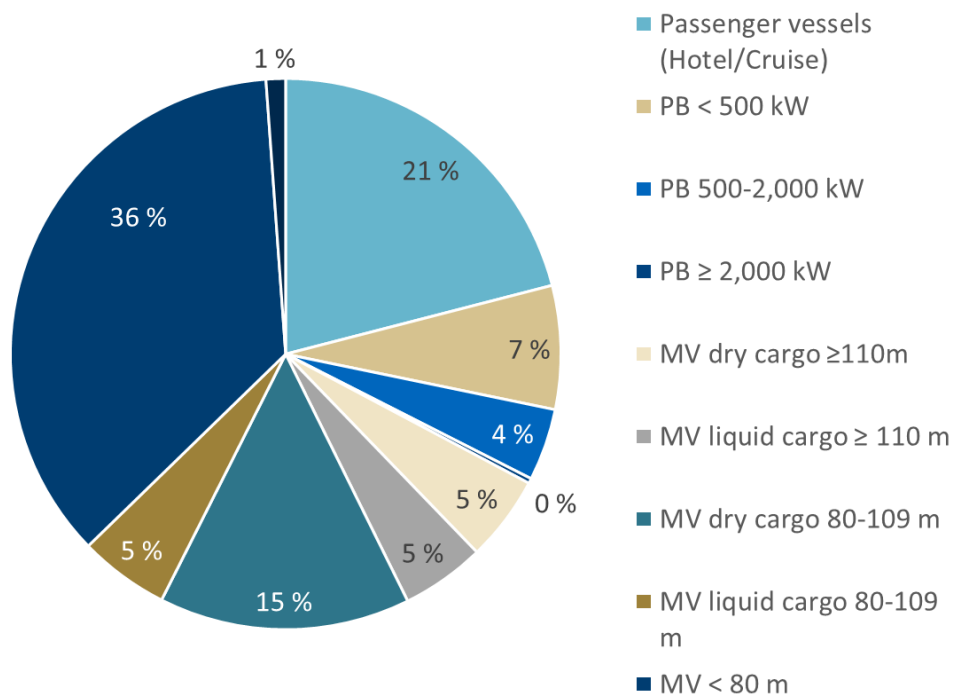

Figure 8: Fleet structure [5]

Figure 9 shows that unregulated engines have still a big share in the current fleet. Figure 10 shows how much fuel is consumed by the fleet family per vessel per year while Figure 11 shows the share per fleet family of the overall fuel consumption.

While the numbers for the installed power only include the main propulsion engines, it is assumed that the fuel consumption also includes the consumption of auxiliary power generators for cargo conditioning, pumps, accommodation and thrusters etc.. The overall fuel consumption also reflects the share of the overall emission as there is no significant number of zero-emission concepts operating up to now.

These findings are very important for the later development of recommendations for actions related to the fleet, as it becomes clear that many vessels operate with a very low emission standard.

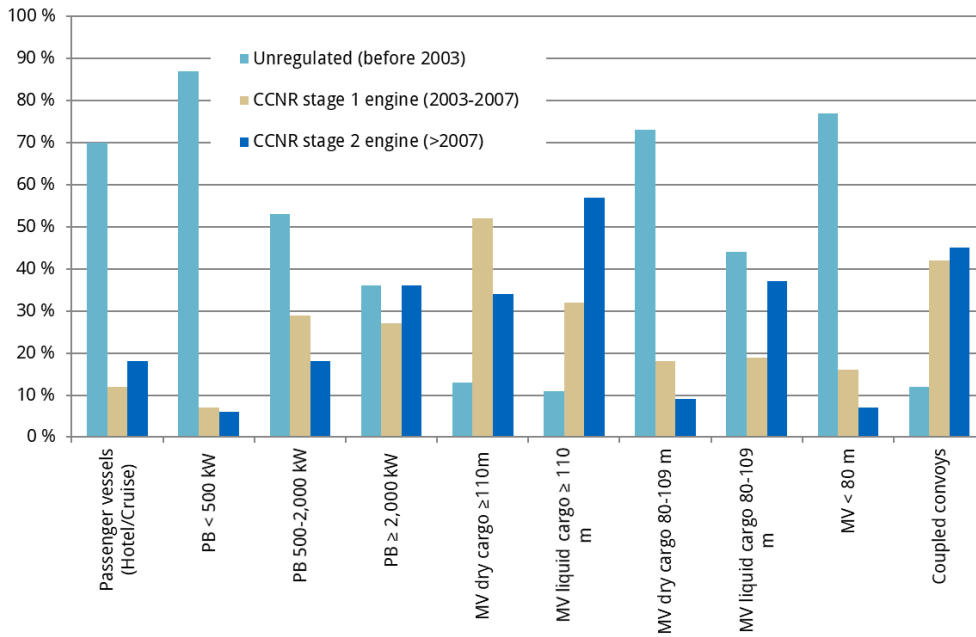

Figure 9: Engine type per main fleet family [5]

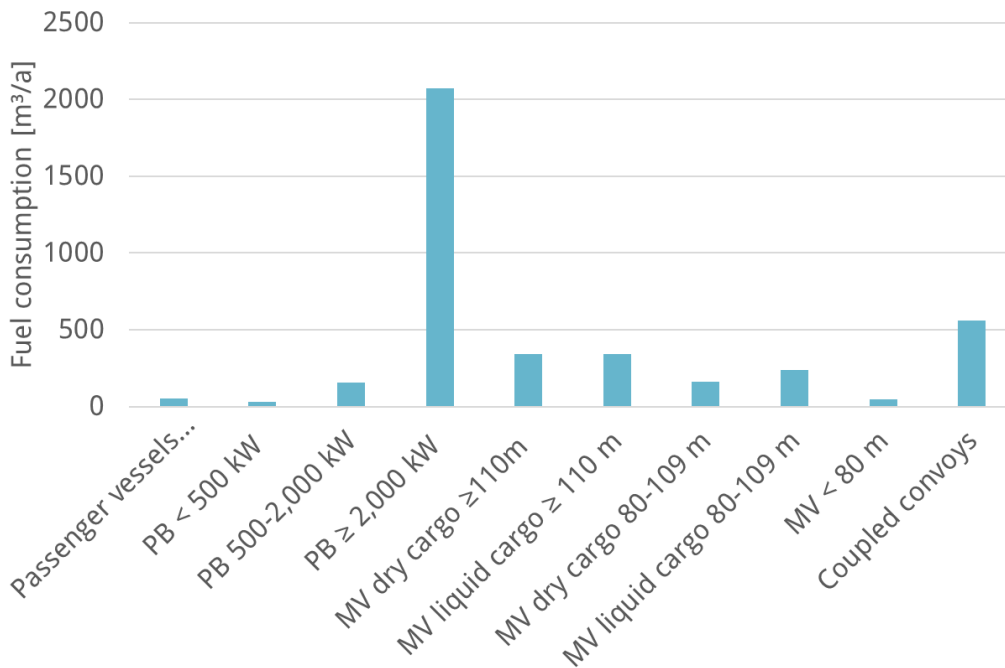

Figure 10: Average fuel consumption per vessel per year [5]

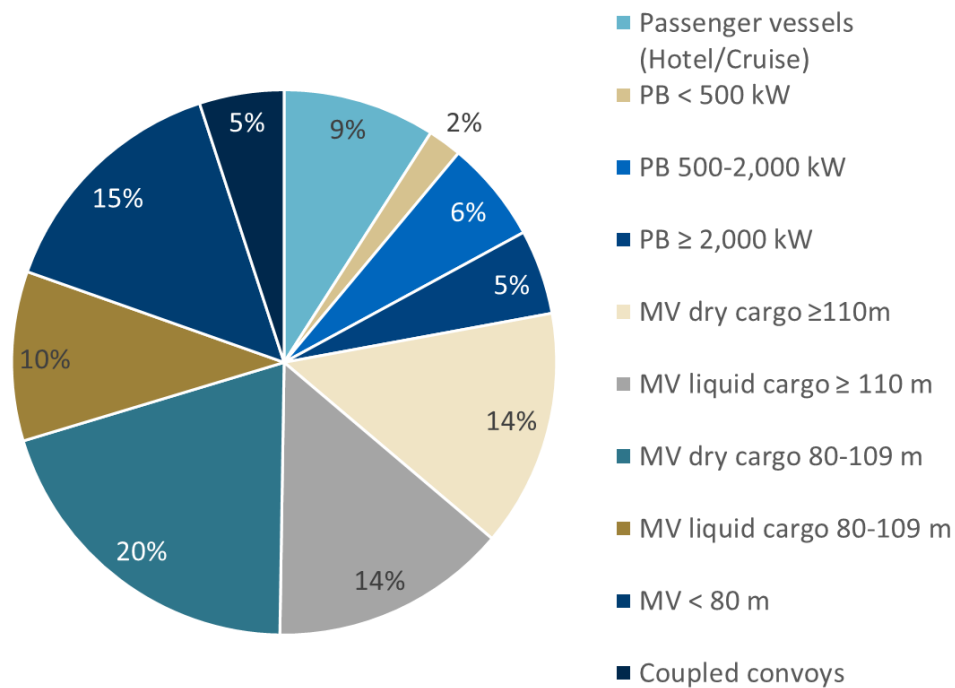

Figure 11: Share of fuel consumption [5]

Table 2: Number of vessels per fleet family [5]

Fleet families identified in PROMINENT	Total number of operational vessels in Europe
Passenger vessels (hotel/cruise vessels)	2,553
Push boats < 500 kW (total engine power)	890
Push boats 500-2,000 kW (total engine power)	520
Push boats ≥ 2,000 kW (total engine power)	36
Motor vessels dry cargo ≥ 110 m length	610
Motor vessels liquid cargo ≥ 110 m length	602
Motor vessels dry cargo 80-109 m length	1,802
Motor vessels liquid cargo 80-109 m length	647
Motor vessels < 80 m length	4,463
Coupled convoy (mainly class Va+Europe II lighter)	140
Total	12,263

Furthermore, from the engines' emission standard distribution (see Figure 9) and the average fuel consumption per fleet family (see Figure 10) and the corresponding

number of vessels the emissions in 2015 were determined. Those are shown in the following Table 3. In average for all engines before CCNR 1, the emission standard US EPA TIER 1 [7] is assumed [8]. In more detail the derived emission factors differentiated per fleet family are given in Table 4. Emission data for the Danube fleet has been developed based on data from CDNI and PROMINENT, in consultation with the Danube Commission and ViaDonau.

Table 3: Estimated emissions of the European fleet in 2015 (calculations based on [9])

2015		
CO ₂	NO _x	PM
[t]	[t]	[t]
4,281,650	47,307	2,386

Table 4: Emission factors differentiated per fleet family for 2015 [9]; for CO₂ always the same value of 720 g/kWh is assumed (see also section 3.2)

Fleet Family	Emission factors [g/kWh]	
	NO _x	PM
Passenger vessels (hotel/cruise vessels)	9.22	0.48
Push boats < 500 kW (total engine power)	9.75	0.52
Push boats 500-2,000 kW (total engine power)	9.07	0.48
Push boats ≥ 2,000 kW (total engine power)	8.26	0.41
Motor vessels dry cargo ≥ 110 m length	8.13	0.42
Motor vessels liquid cargo ≥ 110 m length	7.47	0.35
Motor vessels dry cargo 80-109 m length	9.53	0.51
Motor vessels liquid cargo 80-109 m length	8.39	0.41
Motor vessels < 80 m length	9.63	0.52
Coupled convoys	7.77	0.38
Ferries	10.30	0.54

Daytrip and small cruise vessels	10.30	0.54
----------------------------------	-------	------

3 Greening Technologies

In the context of the finite resources of fossil fuels and the energy transition that has necessarily been initiated in the meantime, as well as climate protection and the discussion about air pollutants emitted by diesel engines, numerous alternatives are being discussed and examined for inland navigation. In general, fleet modernisation and greening are motivated by several aspects:

- Addressing climate change by reduced emissions of fossil CO₂ (global/societal).
- Improved air quality and reduced health related risks by reduced emissions of air pollutants (regional/societal and individual).
- Reduced operating costs by increased efficiency (owners/operators).

At the same time several barriers to reach the desired greening exist:

- Most greening measures are associated with significant investments.
- Complexity of the systems rises, which also increases maintenance costs.
- Energy density of alternative energy carriers requires more space and/or more frequent bunkering.
- Bunkering infrastructure for alternative energy carriers hardly exists.
- Future developments of costs for energy carriers and technologies as well as development of infrastructure are extremely uncertain.
- Today most emission reduction technologies increase the operating costs. No Return on Investment (ROI) can be achieved compared to the current cost structure for conventional diesel drives.
- For most zero-emission technologies the maturity of the technologies themselves can possibly also lead to a barrier as they are not yet broadly in use (fuel cells) or even developed to a satisfying readiness level (battery capacity related to weight and space).
- To avoid an excessive climate change, the energy transition has to happen while there are still large resources of fossil fuels left. Therefore, the balance of supply and demand will not drive the transition sufficiently with increasing costs for fossil fuels.
- The production of green fuels requires sufficient resources of sustainable feedstocks and/or large amounts of cheap renewable electricity.

For the long-term conversion of the fleet, diesel-electric propulsion systems play an important role. Around 200 to 300 diesel-electric vessels are currently in operation on European inland waterways. The electric motors are well suited to the characteristics of the propeller and they can be supplied with energy from different sources. A complete avoidance of exhaust emissions during ship operation is possible with the energy supply from batteries and/or fuel cells.

The first battery-powered Rhine ferry Godesberg - Niederdollendorf was built in Duisburg as early as 1908. On the Straussee in Brandenburg a passenger cable ferry with overhead line, which was put into operation in 1894, is still in operation today. Later, however, such developments were almost completely replaced by robust and economical diesel drives. In the meantime, the long-term increase in gas oil prices and especially the technologies for reducing emissions have led to rising investment and operating costs. At the same time, other energy sources and energy converters are being developed further and are becoming cheaper, so that alternative drive systems are gaining a growing market opportunity and can contribute to a significant reduction in air pollutants and, in some cases, the climate impact of transport in the long term.

Various alternative energy sources are presented in the following as an option to diesel. These can be divided into three groups:

- Hydrocarbon-based energy sources
- Hydrogen-based energy carriers

and

- storage for electrical energy.

Afterwards the related energy converters are described and discussed. The list of assessed technologies was agreed upon with the contracting authorities based on technological maturity, emission reduction potential, suitability for the inland shipping sector and availability of information. As a result, some technologies are not taken into account although they might seem promising.

3.1 Energy Carriers

Nowadays there are various alternatives to diesel available which all have their individual advantages and downsides. As mentioned above, energy carriers can be divided into three groups. The hydrocarbon-based energy carriers all consist of chains of different lengths. Diesel and diesel-like fuels have the longest chains. The following figure shows the proportions of carbon and hydrogen in the various energy sources in their liquid state. In this study, diesel-like fuels, methane, methanol and hydrogen are considered as energy carriers for inland vessels. Production and marine applications of green ammonia as a fuel for internal combustion engines and fuel cells are studied in several current R&D projects. As of today, however, ammonia has not reached sufficient TRL to be included here yet. Batteries are also described in this chapter even though they are rather the tank system than the energy carrier.

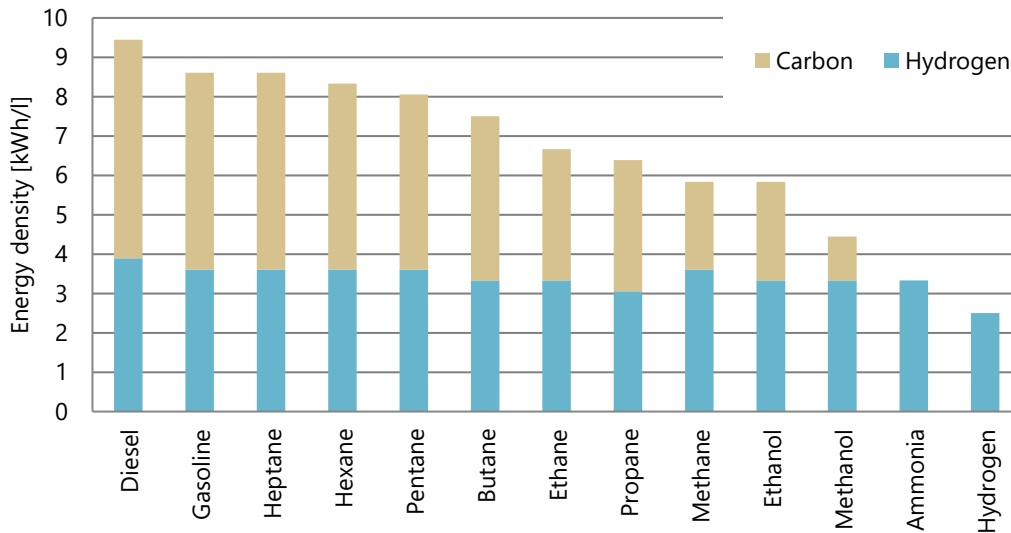

Figure 12: Comparison of energy density as well as carbon and hydrogen content of different fuels [6]

The individual energy sources that can be used have different energy densities, which can be seen in the figure below (1 kWh = 3.6 MJ).

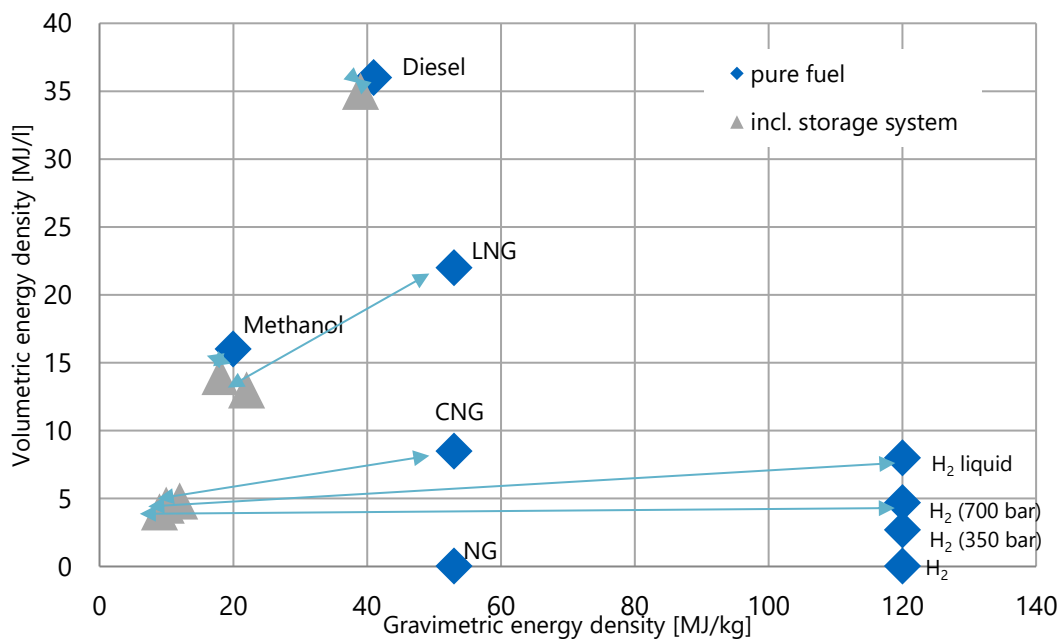

Figure 13: Volumetric energy density over gravimetric energy density for different fuels and storage conditions and at ambient pressure [6]

As the proportion of carbon in the energy carrier decreases, so does its volumetric energy density, a property that is particularly important for inland waterway vessels and therefore a challenge. The difference in energy density can be compensated partly by the higher efficiency of the energy converter in the case of batteries or fuel cell systems in combination with electric motors.

3.1.1 Hydrogen

Since hydrogen does not occur naturally on earth as a single molecule, but only as a chemical compound, it must always be separated to obtain pure hydrogen. Currently, there is much active research on how this process can be made as energy-efficient and climate-neutral as possible.

Hydrogen (H_2) is gaseous under normal conditions (0 °C and 1 bar) with a density of 0.0899 kg/m³. Hydrogen can be transported as compressed gas or liquid and is the most commonly known chemical element. The most advanced processes for the production of hydrogen are reforming and water electrolysis.

When hydrogen is used in the PEM FC, attention must be paid to hydrogen purity. In principle, any hydrogen contamination can impair the performance and service life of the fuel cell system. The required purity is particularly difficult to achieve during the reforming process from natural gas or methanol. The hydrogen purity should be above 99.99 vol%.

The internal combustion engine running on H_2 is also considered in this report. It is described in chapter 3.3.3. For further reading on hydrogen as fuel for inland shipping the feasibility study written within the MariGreen project is recommended [10].

3.1.2 Methanol

Methanol is the simplest member of the group of alcohols with the molecular formula CH_3OH making it rich in hydrogen with only a single carbon bond. It is a clear colourless liquid with a density of 0.79 kg/l. It is produced from fossil sources (natural gas), but can also be produced regeneratively. There are various ways to produce renewable methanol. One is to capture CO_2 from geothermal power generation which is then reacted together with renewable hydrogen (produced via electrolysis) into renewable methanol. Other methods are to convert biogas from fermentation or gasification of sustainable biomass into bio-methanol as well as producing it from solid waste feedstocks. It is also produced as a by-product of the kraft pulping process by process industries.

Methanol can be used in adapted combustion engines or as energy carrier for hydrogen fuel cells. Reforming at 300 °C produces H_2 -rich reformat gas. When used with a low temperature PEM FC, a fine purification is necessary. Reforming reduces the system efficiency of a FC system.

Methanol is harmful to the environment (same water hazard class as diesel) and health but biodegradable. Due to the liquid property of methanol (it remains liquid up to a temperature of 60 °C and ambient pressure), handling is similar to that of diesel or petrol, i.e. it can be stored in simple tanks. In combination with the comparably high energy density this is the strongest advantage of methanol.

The passenger vessel MS Innogy on the German lake Baldeney uses green methanol in a fuel cell system with integrated reformers of the Danish company SerEnergy.

3.1.3 Ammonia

The use of ammonia as fuel in inland navigation is also considered. Since ammonia does not contain carbon, it is a fuel outside the carbon cycle and has (except from possible emissions of nitrous oxides) no direct effect on the climate. Since the 1940s, there have been repeated attempts to establish ammonia as a fuel [11]. Today, ammonia is produced on an industrial scale, mainly using the Haber-Bosch process utilizing nitrogen and hydrogen (see Fig. 12) as the basis for fertilizers, which requires about 3 % of the electrical energy generated worldwide [12]. The energy consumption in large plants producing up to 1500 t/d is estimated in [13] at 8 MWh/t when CH₄ is used as the source of hydrogen, or 13.5 MWh/t when coal is used. Before ammonia can be used as a climate-friendly fuel, new processes for its production must be applied. At the RWTH Aachen University, for example, the electrochemical membrane reactor process (ecMR), which can be operated entirely with renewable energies, was developed. Here, a so-called membrane electrode unit is used, which increases not only the reaction speed but in addition the efficiency of the process [13]. Another process is the Solid State Ammonia Synthesis (SSAS), which can also be operated with renewable energies [14]. Both processes are still in the development phase and have not yet been used commercially.

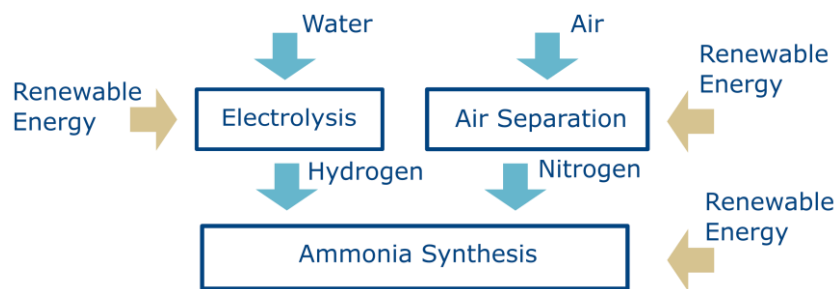

Figure 14: Power to Ammonia [6]

Ammonia has a corrosive effect on most common materials, which makes it more difficult to use as a fuel. The toxicity of ammonia must also be taken into account; there are recommendations to assess this within a separate risk analysis (cf. [15]).

As neither the production process is climate-neutral yet, nor is the engine technology commercially available, ammonia is currently not a fuel immediately ready to be used for inland navigation. However, if the obstacles described above are overcome, ammonia could either be used directly (together with a small share of e.g. hydrogen to achieve ignitability) as a fuel in an internal combustion engine or as a hydrogen source for a fuel cell.

3.1.4 Dimethyl Ether

Dimethyl Ether (CH₃OCH₃) is the simplest ether compound. It can be produced directly from syngas. The feedstock and the required energy can be obtained from renewable sources [16]. Moreover, DME can be produced in a Power-to-X process plant. The colourless and highly flammable substance is gaseous under ambient conditions. When

subjected to modest pressure (10 bar) or cooling (-25°C) it changes to a liquid. In contrast to most other fuels, DME is almost non-toxic.

Under the Biofuels Directive 2009/28/EC, dimethyl ether is considered a biofuel if it is produced from biomass and is intended for use as biofuel. The Horizon 2020 project FLEDGED (grant agreement N° 727600) deals with the production of DME from biomass using more efficient process technology [17].

3.1.5 Drop-In Fuels GTL, HVO and PTL

Drop-in fuels are a synthetic and completely interchangeable substitute for conventional petroleum-derived hydrocarbons (gasoline, jet fuel, and diesel), meaning it does not require significant adaptation of the engine or the fuel system. Usually, they are standardized as paraffinic fuels according to EN 15940 and can be used “as is” in currently available engines either in pure form and/or blended in any amount with conventional fuels. However, lubricants and some engine control parameters might need to be changed in coordination with the engine manufacturer to improve efficiency and / or environmental performance. Therefore, the fuel has to be specified in the manufacturer’s fuel directive and the type approval for each engine series according to the recent emission standards. Since the type approval process is elaborate and costly compared to the small market, standardization and the future usage and availability of blends or pure drop-in fuels have to be coordinated far in advance. The guidelines related to this topic and published by the Internal Combustion Engine Manufacturers (EU-ROMOT) [18] can be surveyed online and are subject to continuous further development.

Among the synthetic fuels that are considered important for inland navigation are GTL (Gas-to-Liquid) and HVO (Hydrotreated Vegetable Oil). GTL is produced with the Fischer-Tropsch synthesis, a process generally called XTL (X to Liquid) that was developed by Franz Fischer and Hans Tropsch in 1925. The “X” is a variable and is replaced by an abbreviation of the original energy carrier, e.g. “G” for gas. Within this process various liquid synthetic fuels such as GTL, lubricating oils and other paraffinic products for the chemical industry can be obtained from natural gas, other gasified fossil fuels or biomass. If biomass is used as a starting material, also the term BTL (Biomass-to-Liquid) is commonly used, replacing the “X” by “B”. BTL is completely derived from renewable energy.

HVO is a mixture of straight-chain and branched paraffins, the simplest form of hydrocarbon molecules under the aspect of clean and complete combustion. Typical carbon numbers are C15 ... C18. In addition to paraffins, fossil diesel fuels contain also significant amounts of aromatics and naphthenes. Aromatics impair a clean combustion. HVO, on the contrary, does not contain aromatics, and its composition is similar to that of GTL and BTL diesel fuels, produced by the Fischer-Tropsch synthesis from natural gas and gasified biomass. Having said that, it is to be emphasised that HVO is not to be mistaken with Biodiesel (see also Figure 15). Biodiesel is a chemically fatty acid methyl ester (FAME) and could cause trouble being used as a fuel substitute in a conventional engine. Increasing the blends of FAME is a greater challenge than for HVO and not covered by

usual test fuels. The feedstock for HVO consists of renewable sources. These can be residual plant and animal fractions from the food industry or residues from vegetable oil processing. The fuel HVO is considered to be climate neutral in the tank-to-wake cycle. This is in line with the IPCC assumptions [1] and also confirmed by the 2019 energy transition outlook published by DNV GL [19]. Here it is explained that carbon contained in biomass is eventually absorbed from the atmosphere by photosynthesis by the plants replacing the burned plants. Other factors such as potential additional emissions due to e.g. deforestation to make room for crops producing biofuel are accordingly accounted for under agriculture, forestry and other land-use (AFOLU) not the transport sector also documented in IPCC volume 2, chapter 3 mobile combustion [20].

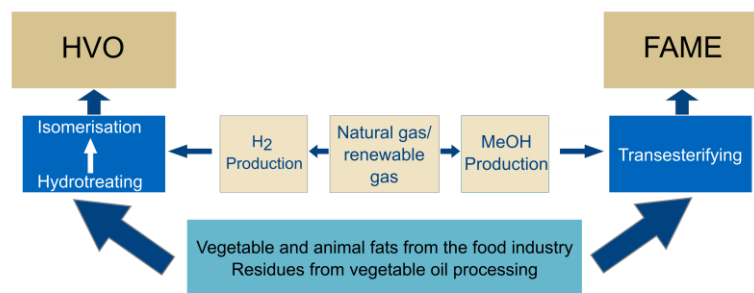

Figure 15: Process of HVO production, which is a catalytic process with hydrogen (hydrogenation) and difference to the production process for biodiesel (FAME, shown to the right), which is an esterification [21]

The synthetic fuel produced entirely from renewable energy sources is called PTL. Here the P stands for power. An electrolyser is operated with electricity generated from renewable sources to separate hydrogen. Then, again using a Fischer-Tropsch process, a synthetic, diesel-like fuel is produced from the hydrogen and added carbon. The output of today's PTL refineries is still very low; and therefore, an immediate switch to this fuel is unfeasible. However, as market interest in this fuel increases, it can be expected that production capacity will increase significantly. Figure 16 shows the production cost for different fuels from renewable sources. Besides the sustainable feedstocks the viability of these fuels is highly dependent on cheap renewable electricity.

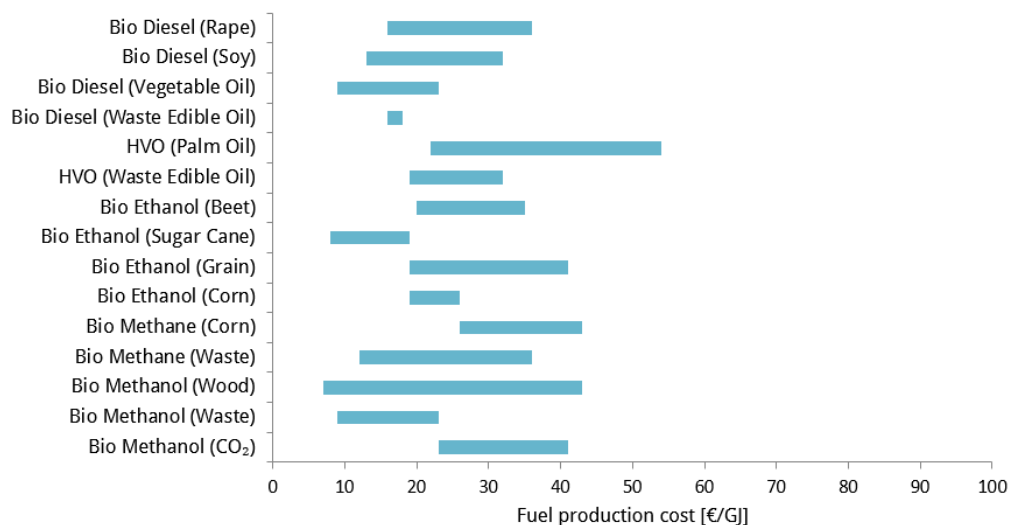

Figure 16: Production cost for different fuels from renewable sources [22], [23]

Following a report published by [22] possible quantities of alternative fuels in 2030 are as outlined hereafter: “Due to current fuel standards, individual biomass-based fuels (BTX) and synthetic fuels (PTX) such as ethanol, methanol or dimethyl ether (DME)/oxymethylene ether (OME) can currently only be blended to a limited extent. Today's most important BTX fuel, biodiesel (fatty acid methyl ester, or FAME), is used as a 7 % blend with fossil diesel (B7), but can also be used as B20, B30 or B100 (pure fuel) by approved commercial vehicles in closed fleets. Other biomass or electricity-based products, for example methane, can be blended with fossil fuels (in the case of methane to Compressed Natural Gas (CNG) or Liquefied Natural Gas (LNG)) in any amount (0-100 %). After a successful drop-in phase and when substantial production quantities have been reached, special PTX fuels can also be marketed as "designer fuels" at separate fuel stations.”

Anyhow, without further measures the expected share of renewable fuel as per [22] in Germany in 2030 will be approx. 9 % of the overall fuel consumption. This also holds a percentage already applied in 2015. Therewith it contributes but will not yet archive the aim of increasing the use of renewable energy by 35 % compared to 2015.

In combination with the latest emission standards, the use of drop-in fuels can make a major contribution both to reducing climate-impacting emissions and to lowering air pollutants. The emission potential of drop-in fuels is described in section 3.2.

3.1.6 Battery

Batteries provide the possibility to store electrical energy and make it available on the move. Batteries are used in a wide range of application with a lot of different requirement. Thus, there is a wide range of battery types and developments are going in various directions. Batteries can be characterised by the following factors: power density, capacity, cycle lifetime, energy density, capital costs, charging time, reliability and safety.

The following battery types are available:

- Lead-acid
- Li-ion
- Sodium sulphur
- Nickel-based
- Others: sodium-ion, magnesium-ion, zinc, and aluminium

Figure 17 shows an example of the functional principle of a battery based on a lithium-ion cell. Beside all varieties of different batteries, they all share about the same construction. A battery cell consists of two electrodes, the negative anode and the positive cathode, which are enclosed by an electrolyte. The electrolyte can be made of liquid, gel or solid materials. For both electrodes and electrolyte different chemical matters are used.

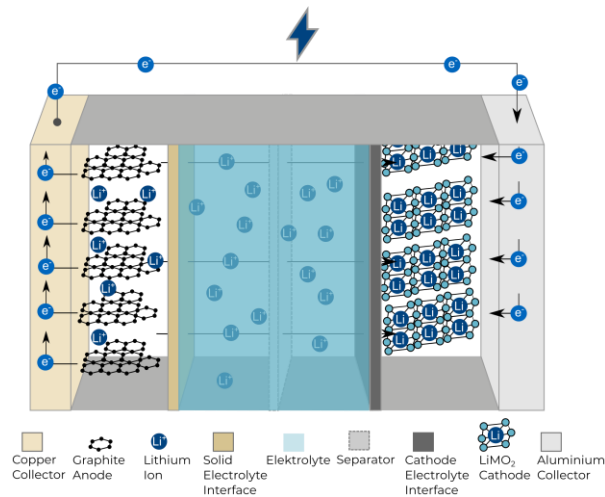

Figure 17: Functional principle of a lithium-ion battery

Discharging of a battery means to convert chemical energy to electrical energy. For charging a battery, current has to be spread. All reactions are returned. Nevertheless, the controlled reversal for most cases is not perfect. Therefore, the number of charges is bounded.

The different battery types are usually classified by their cathode chemistry. The five current available solutions are:

1. lithium cobalt oxide (LCO)
2. lithium iron phosphate (LFP)
3. lithium nickel cobalt aluminium oxide (NCA)
4. lithium nickel cobalt manganese oxide (NCM)
5. lithium manganese oxide (LMO)

Further, the anode material as well as the electrolyte can change. An example is the lithium titanate oxide anode (LTO).

Battery systems

Maritime battery systems typically consist of several thousand cells. It is, therefore, important that each cell works consistently with all other cells. The individual battery cells are interconnected to form battery modules, whereby the required voltage is reached. Due to the net-working of these units, large systems with a high capacity can be assembled.

The advantage is that the battery systems can either be integrated into the hull of the ship or it can be installed in separate battery cabinets assembled e.g. in a container. Battery containers could then be inter-changeably stored on the ship. This solution might be of special interest for ships handling containers as their usual business anyhow.

3.1.7 LNG

Liquefied natural gas (LNG) mainly consists of methane (CH₄). Due to its lowest possible carbon content (see also Figure 12) methane has a great potential to reduce CO₂ emissions when used as fuel. Nevertheless, since methane is a very climate-impacting gas, methane slip must be kept under control when LNG is used as fuel in order to maintain the advantage of low emissions from combustion; and to ensure reductions in greenhouse gas (GHG) emissions while using LNG.

LNG is produced by cooling down the natural gas to minus 162 °C (-260 °F), thus converting it to liquid state for ease of storage and transport. Methane could also be produced as a power-to-X fuel. Just like bio methane, it can be used directly as a renewable substitution.

LNG consists of more than 90 % methane (CH₄) with the rest mostly ethane, propane, butane and nitrogen. It is odourless, colourless, non-toxic, non-corrosive and has a flammability range of 5-15 % of fuel-air mixture. LNG shall not be mistaken for LPG – Liquefied Petroleum Gas (mainly consisting of propane and butane). In case LNG is spilled it evaporates, forming visible “clouds”. Portions of the cloud could be flammable or explosive under certain conditions. A fuel-air mixture of about 10 % methane in air (about the middle of the 5–15 % flammability limit) and atmospheric pressure might be ignited if it does encounter an ignition source (a flame or spark or a source of heat of 540 °C or greater). Otherwise the vapour will generally dissipate into the atmosphere

LNG contributes to significant reduction of sulphur oxides emissions (SO_x), nitrogen oxides emissions (NO_x), particulate matters (PM) and carbon dioxide emissions (CO₂) from engine exhaust emissions in comparison to traditional fuels. However, differences are substantially reduced by low sulphur fuels and exhaust gas aftertreatment.

In comparison to diesel:

- CO₂ reduced up to 25 % (for near zero methane slip, in the following calculated with 13 %)
- PM reduced by nearly 100 %
- NO_x reduced up to 90 %
- SO_x reduced up to 95 %

In comparison to LPG:

- GHG reduced by up to 15 %
- PM reduced by up to 10 %
- NO_x reduced by up to 50 %

3.2 Emission reduction potential

The following tables summarize the emission factors used (Table 5) and the corresponding reduction potential (Table 6) compared to the situation in 2015 (Table 4) for the clean drivetrains in a tank-to-wake perspective. For the diesel engines an average CO₂ emission factor of 720 g/kWh was used, though e.g. old unregulated and modern engines have a slightly better efficiency than a CCNR II engine. The value is based on a specific fuel consumption of 230 g/kWh which represents the average value for an operating profile of a vessel with frequent operating conditions in partial load range. The emissions output depends on the fuel molecular structures and was set to 3.15 g_{CO2}/g_{Die-sel} for Diesel. The numbers presented in the tables below are based on own calculations taking into account numbers from [24] and [5].

Table 5: Emission factors for drivetrains complying with Stage V or better

Drivetrain technology	CO ₂ [g/kWh]	NO _x [g/kWh]	PM [g/kWh]
Battery	0	0	0
Hydrogen in fuel cells	0	0	0
Bio-Methanol in fuel cells	0	0	0
LNG	637	1.8	0.015
Hydrogen in ICE	0	1.8	0
GTL	720	1.8	0.015
HVO	0	1.8	0.015
PTL	0	1.8	0.015

Table 6: Emission reduction potential of alternative fuels with ideal upstream chains

Fuel	CO ₂	NO _x	PM
Battery	-100 %	-100 %	-100 %
Hydrogen in fuel cells	-100 %	-100 %	-100 %
Bio-Methanol in fuel cells	-100 %	-100 %	-100 %
LNG	-13 %	-84 %	-97 %
Hydrogen in ICE	-100 %	-84 %	-100 %
GTL	-0 %	-84 %	-97 %
HVO	-100 %	-84 %	-97 %
PTL	-100 %	-84 %	-97 %

LNG, GTL, HVO and PTL are assumed to be used with a Stage V engine and compared to the fleet in 2015. For assumptions related to the tank-to-wake cycle see also section

3.1.5. The emission factors of the large Stage V engines above 300 kW are used as a basis for all Stage V engines covering the differences in real sailing conditions of small IWA/IWP engines up to NRE (<560 kW) and Euro VI. The CO₂ reduction of LNG takes into account a moderate amount of methane slip. This is an ongoing topic in R&D aiming at further reduction. Currently there is a high share of dual-fuel engines in IWT with higher methane slip compared to mono-fuel engines. But even though mono-fuel engines are less popular due to their limited application possibilities, dual fuel engines still suffer from this issue [25].

3.3 Energy Converters

This chapter describes the energy converters. This includes on the one hand the classic diesel engine, which, optimized and equipped with the latest exhaust after treatment systems and operated with a climate-friendly fuel, is a good option for many applications. On the other hand, new energy converters for inland navigation such as the fuel cell, purely electric propulsion concepts and the hydrogen combustion engine will also be introduced.

3.3.1 Stage V and Euro VI engines

The starting point is the classic internal combustion engine. It is unsurpassed on inland waterway vessels, where high performance is required over a comparatively long period of time.

Diesel is expected to continue to be the main energy source for the fleet in the near future. However, it is conceivable that this will be supplemented by renewable blends in order to come closer to the climate goals. Alternative fuels are further specified in chapter 3.1.

The new limit values have a particular impact on emissions harmful to health. The regulations require manufacturers to install catalytic converters and particulate filters in order to comply with the limits. The EU Directive 2016/1628 [24] sets the latest emission limits, which are much stricter compared to the elder CCNR I and CCNR II stages. Especially the addition of the PN limit is a major reinforcement. It can be expected that these emission limits will not be the last, but that developments will continue. The following Figure 18 illustrates the different limits. The Californian SULEV limits (super ultra-low emissions vehicle) are included to show, that Stage V or Euro VI do not mark the technical emission reduction limit.

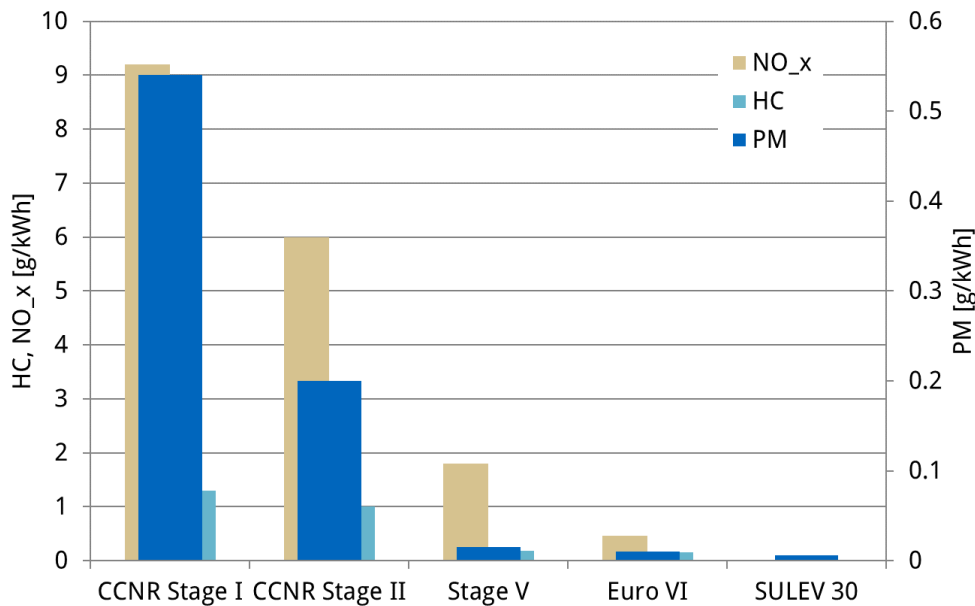

Figure 18: Emission limits for Stage I to Stage V for HC, NO_x and PM [26]

3.3.2 Gas and gas-electric propulsion concepts

The technical approach applied to the propulsion of inland waterway vessels depends on the type of vessel, the speed targeted and the sailing profile. In order for gas and gas-electric propulsion to be applicable, a vessel should meet one or more of the following criteria:

- High energy demand and a load factor benefitting from reduced energy costs
- LNG bunkering infrastructure within the operational area
- Benefits from LNG retrofitting in combination with lengthening of the hull (applicable especially for pushers).

The technology for using LNG on ships is commercially available. However, the comparatively high price of the cryogenic system components is an obstacle, especially in inland navigation. The following picture shows the necessary equipment:

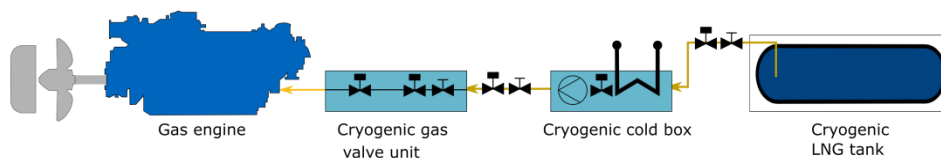

Figure 19: General schema of the system components of a LNG powered drive train

The use of LNG to power fuel cells is also feasible. Guidelines for the use of fuel cell systems on board of ships are amongst others available by the classification company DNV GL and currently further under development. With the ambition to take zero-emission technology a big step ahead considerable development work is provided in this field.

Engine types

LNG power offers a number of engine configurations for inland waterway vessels. Either a full gas-engine (Otto-cycle) as displayed in Figure 21 or a dual-fuel engine (Diesel-cycle) displayed in Figure 20 can be used. In case of the dual-fuel engine, which is the majority of the current LNG fleet, the ratio of diesel and gas is variable. However, the emission performance is lower than for the mono-fuel engines, which are preferred in gas electric installations.

Dual fuel engine (Diesel-cycle)

In dual-fuel mode, natural gas is fed into the engine's intake system. The air-natural gas mixture is then drawn into the cylinder, just as it would be in a spark-ignited engine, but with a leaner air-to-fuel ratio. Near the end of the compression stroke, diesel fuel is injected and ignites the natural gas. A dual-fuel engine can operate on pure diesel fuel or a mixture of diesel and natural gas, delivering the same power density, torque curve and transient response as the base diesel engine.

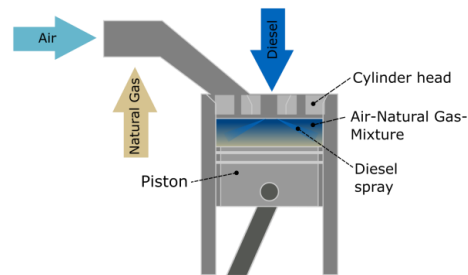

Figure 20: Dual fuel engine (Diesel-cycle)

Gas engine (Otto-Cycle)

Mono-fuel gas-engines work with the Otto principle and have a spark-ignition. They also have a different characteristic which is slightly more suitable for gas-electric applications in gensets than for direct drives.

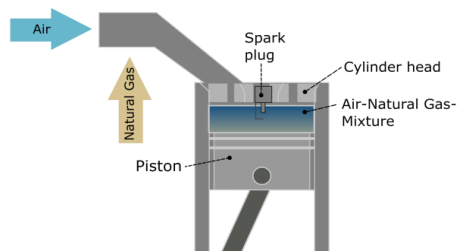

Figure 21: Gas engine (Otto-Cycle)

Propulsion concepts

Basically, one can divide between direct drive (see Figure 22) and gas-electric drive propulsion concepts (see Figure 23). The two concepts are listed hereafter.

Direct drive system

The direct drive system with a gas engine is comparable to a diesel direct drive system. In the context of the required redundancy, it may be necessary to install two independent gas supply systems including a tank for multi screw vessels. A single screw vessel has the option to use the bow thruster (360° thruster) as redundant propulsion device in case the gas system fails. The bow thruster then also needs an independent energy source.

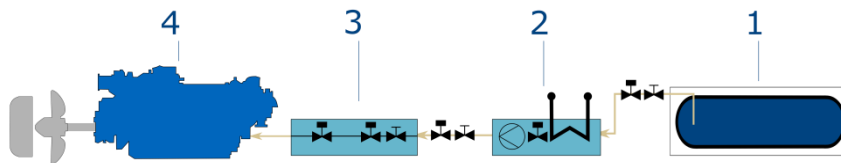

Figure 22: General schema of the components of a direct drive system

- 1 Pipes and tanks have safety valves to protect them from overpressure. All systems are redundant. This means that of each safety system there are at least two individual ones available in case one fails.
- 2 In the Cold Box the LNG is evaporated. The resulting gas is then pressurized. The energy (heat) for the evaporation process is often delivered by the cooling water of other engines on board. This part of the installation is also known as gas treatment system. The pipes are double walled. The space between the inner and the outer pipes is flooded with Nitrogen. Each pipe has an automatic and a hand operated valve; each piping section also has a release valve. The automatic valves are closed at an emergency shutdown.
- 3 The gas valve unit (GVU) controls the gas flow to the engine and can also perform an emergency stop.
- 4 In the engine the gas is burned. The two main engine types are dual-fuel engines running on diesel as well as gas and pure gas engines running on gas only. In case of a dual-fuel engine, an additional diesel tank is necessary.

Gas-electric system

The design of the gas-electric system is comparable to that of the diesel-electric system: both are using gensets and electric drive motors. Only the gensets in the concept described here now run on gas. A requirement of the applicable regulation ES-TRIN 2019 is a redundant electric energy source. One solution to satisfy this demand, the installation of two gensets is shown below in Figure 23. The gensets may differ in size.

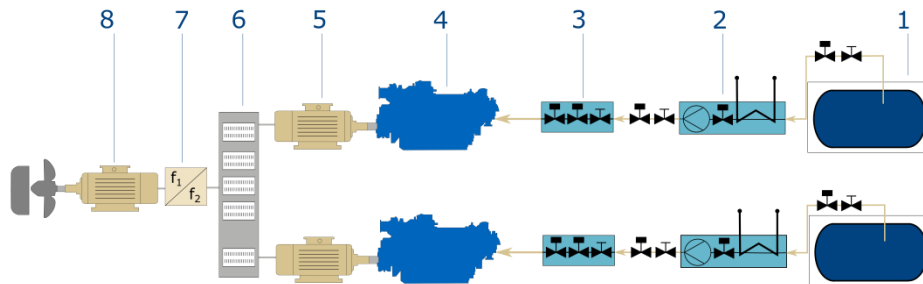

Figure 23: General schema of the components of a gas-electric system

- 1 Pipes and tanks have safety valves to protect them from overpressure. All systems are redundant. This means that of each safety system there are at least two individual ones available in case one fails.
- 2 In the Cold Box the LNG is evaporated. The resulting gas is then pressurized. The energy (heat) for the evaporation process is often delivered by the cooling water of other engines on board. This part of the installation is also known as gas treatment system.
- 3 The Gas Valve Unit (GVU) controls the gas flow to the engine and can also perform an emergency stop.
- 4 In the engine the gas is burned. The two main engine types are dual-fuel engines running on diesel as well as gas and pure gas engines running on gas only. In case of a dual-fuel engine, an additional diesel tank is necessary.
- 5 The generator set consists of a combustion engine combined with an electric generator. The combustion engine drives the generator to convert the chemical energy of the fuel into electrical energy. The generator can provide AC or DC power, depending on the selected main switch board and frequency converters.
- 6 The main switch board distributes the energy from all sources to all consumers. The consumers are frequency converters of the propulsion systems, hotel load, pump systems and so on. The system could be designed as a single AC or DC rail, which can be separated in a starboard and portside system.
- 7 The frequency converter supplies the electric motor with a frequency and voltage amplitude variable AC voltage. The converter can be supplied by

any AC or DC on board energy grid. The rotational speed of the electric motor is controlled, by varying the output frequency.

- 8 The electric motor drives the propeller at any desired load case. Its advantage is a nearly constant efficiency at all load cases. Depending on the selected electric motor a gear box is omissible.

Equipment for gas powered inland vessels

Besides engines, special safety provisions (crew training, bunkering requirements) and additional equipment are required to propel an inland waterway vessel on LNG. These are components like LNG tanks as well as systems for LNG withdrawal from a tank or a cold box as described hereafter.

LNG Tanks

Two different types of LNG tanks are available: Membrane Tanks and Pressure Tanks. For LNG as fuel only the Pressure Tanks (IMO Type C Tanks) are interesting. They are mostly cylindrical and have either a vacuum or foam insulation as shown in Figure 24 and Figure 25. For the vacuum insulation the space between the inner and outer hull is filled with perlite, an insulation material, then the vacuum is drawn. Another option is foam insulation; here the heat transfer is higher.

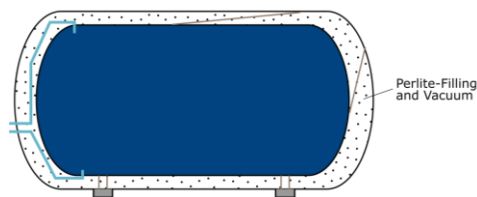

Figure 24: Pressure tank (vacuum insul.)



Figure 25: Pressure tank (foam insulated)

3.3.3 Hydrogen in combustion engines

Not only can hydrogen be used as fuel for a fuel cell but also for the classic internal combustion engine (ICE). Lately manufacturers have started the development of commercially available engines [27].

In contrast to the fuel cell or the battery, no rare-earth metals are needed for the production of the combustion engine.

Being carbon-free, makes the hydrogen operation of the combustion engine at least theoretically CO₂, CO and hydrocarbon-free. In real operation, however, traces of hydrocarbons in the exhaust gas can be detected due to lubricating oil in the combustion chamber. The local emission of nitrogen oxides, though, must be taken into account [28].

The formation of nitrogen oxides in combustion can, for example, be greatly reduced by appropriate regulation. The remaining nitrogen oxides in the exhaust gas are then retained by a catalyst (SCR) [29].

Theory

The wide ignition limits of hydrogen allow quality control over the entire operating range of the engine. In contrast to conventional fuels, hydrogen can theoretically be burned homogeneously up to an air ratio of $\lambda = 10$. As with conventional fuels, the required ignition energy increases with the air ratio. To ignite a stoichiometric hydrogen-air mixture, only one tenth of the energy required to ignite a gasoline-air mixture is needed. In contrast, the self-ignition temperature of hydrogen is significantly higher than that of conventional liquid fuels. Although this can bring advantages in terms of knocking behaviour in the case of premixed combustion, it requires very high compression ratios or other measures to increase the charge temperature in the case of the self-igniting hydrogen engine.

The high laminar flame velocity of about 230 cm/s shows that extremely short, efficient burning times can be achieved with hydrogen. Even with lean mixtures, the laminar burning speed is significantly higher than that of conventional fuels. However, in the premixed combustion of stoichiometric mixtures the engine is more heavily loaded and induced by the rapid and thus higher pressure increase, which also leads to higher combustion noise.

Being carbon-free, makes the hydrogen operation of the combustion engine at least theoretically CO₂, CO and hydrocarbon-free. In real operation, however, traces of hydrocarbons in the exhaust gas can be detected due to lubricating oil in the combustion chamber. The local emission of nitrogen oxides, though, must be taken into account. [28]

The formation of nitrogen oxides in combustion can, for example, be greatly reduced by appropriate engine control. The remaining nitrogen oxides in the exhaust gas are then retained by a catalyst (SCR). [29].

3.3.4 Battery Electric Drives

The concept of electric propulsion describes in the first place the propulsion with a motor that converts electrical power into motion, regardless the origin of the electric power. Thus, the whole system can be divided into the motor itself and the energy supply. As energy supply batteries and fuel cells can be considered.

For an integrated assessment of the ecological and economical benefit, all components have to be considered, meaning the hardware, such as the motor, battery and fuel cell, as well as the origin of the power for charging the batteries and the kind of fuel which is used for the fuel cell.

The first applications for battery electric propulsion were realised on small vessels like ferries or excursion ships, where the travel path and time is short and the possibility for loading the batteries is given during breaks. Thus, the battery can be small. For a

long time, the problem was that the battery for long travels would have been too big and too heavy, or the capacity and therefore the range of travel too short.

However, technology has developed and since 2017 two battery electric driven vessels operate in the port of Rotterdam and Antwerp. With 110 m length and 11.45 m width, both vessels are able to transport 280 containers. The batteries are stored in containers underneath the liftable wheelhouse. They can either be exchanged or loaded within 4 h at special loading stations. The capacity of the batteries is 7.2 MWh, which corresponds to a travel time of 35 h.

Engine types

The basic principle of electric motors is the conversion of current (electric power) into movement with the help of magnetic fields. The motor consists of a fixed, magnetic outer part (stator) and a rotating inner part, with a changing magnetic field (rotator). The rotation of the rotator is induced by the changing magnetic field and the alternative pushing and pulling forces of same and different magnetic poles. The current is used to switch the magnetic field. Electric motors can be classified according to the type of current source. They can operate either with direct current (DC), alternating current (AC) or three-phase current. Alternating current and three-phase current driven motors can further be divided according to other specifications. Depending on the specific application, the optimum motor can be chosen.

The efficiency of converting electrical power into movement is about 85 % compared to diesel engines with an efficiency of about 40 %. Compared to combustion engines there are further advantages.

Electric motors are used in a wide range of application and scales and for a long time. Thus, the development is well-advanced. Nevertheless, there is still potential to make them even more efficient.

Some possible improvements:

1. The use of high-temperature superconductors: With the use of high-temperature superconductors a lossless transport of electric energy would be possible. However, the need to cool the system down to ~ 77 K is not suitable for all applications.
2. The optimization of the control system, such as the optimization of the speed control.
3. Optimization of the motor construction. Use of aluminium instead of copper. More precise construction to minimize the gap between stator and rotor.

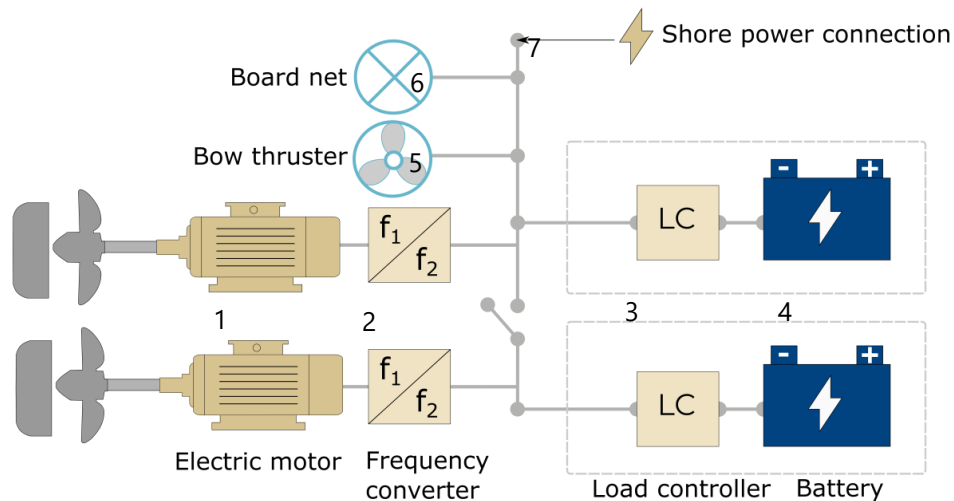

Figure 26: General schema of the components of a battery electric drive system

The electric motor drives the propeller with constant rpm (revolutions per minute) at any load case. Its advantage is a nearly constant efficiency at all load cases. Depending on the selected electric motor a gear box can be omitted. The frequency converter supplies the electric motor with a frequency and voltage amplitude variable AC voltage. The converter can be supplied by any AC or DC on board energy grid. The rotational speed of the electric motor is controlled by varying the output frequency. The loads are frequency converters at the propulsion systems, bow thruster (5), board net (6), pump systems, etc.. It can be designed as a single AC or DC rail, which can be split in a starboard and portside system. The batteries can also be charged via a shore power connection.

3.3.5 Fuel cell systems

Installing a fuel cell system requires space for the hydrogen tank, the fuel cell itself as well as batteries. The general schema of a fuel cell system is shown in Figure 27.

Technical concept

The electric motor (1) drives the propeller with constant rpm at any load case. Its advantage is a nearly constant efficiency at all load cases. Depending on the selected electric motor a gear box can be omitted. The frequency converter (2) supplies the

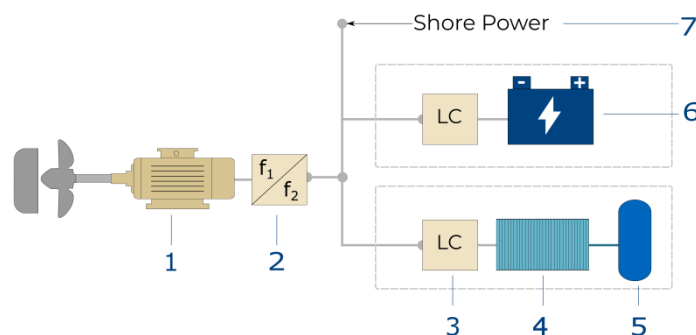

Figure 27: General schema of a fuel cell system

electric motor with a frequency and voltage amplitude variable AC voltage. The rotational speed of the electric motor is controlled by varying the output frequency of the converter. The converter can be supplied by any AC or DC on board energy grid. The main switch board (3) distributes the energy from all sources to all loads. The fuel cell (4) provides the base load. The fuel is stored in the tank (5). Peak loads are

absorbed by the battery (6) which can be charged either by the fuel cell or via shore power (7).

Fuel cell types

The following diagram shows the basic conversion process in a fuel cell using the example of hydrogen as a fuel.

Basic working principle of fuel cells

All fuel cells consist of two electrodes - the anode and the cathode as shown in Figure 28. These are separated by an electrolyte with an ion-permeable membrane. After the fuel has been supplied to the anode, it is divided into electrons and protons. The free electrons flow into an outer circuit between the anode and cathode to be used as an electric current. The protons spread through the electrolyte to the cathode. At the cathode, the oxygen from the air combines with the electrons from the outer circuit and protons from the electrolyte. This results in water and heat.

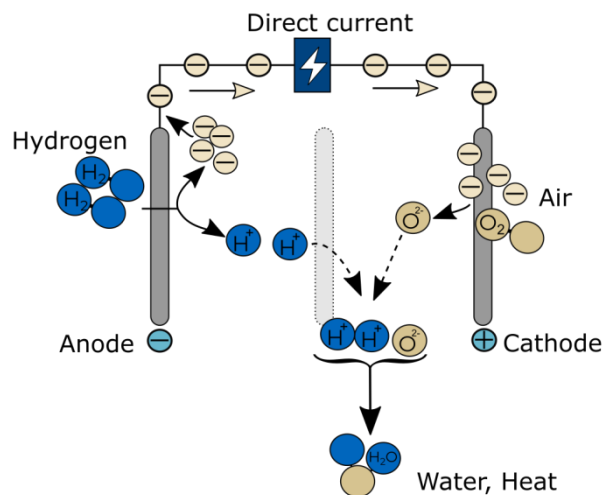

Figure 28: Basic working principle of fuel cells

Several fuel cells in a row make up a fuel cell stack. The number of individual cells that are connected in series can be used to variegate the performance of the stack and adapt it to the respective requirements.

All fuel cell types are based on the reaction of a fuel with oxygen. The electrochemical reaction generates basically electricity, heat and water. From the fuel cell, the electricity is provided as direct current (DC). If alternating current (AC) is required for further use, DC from the fuel cell is routed to an inverter is converted there to AC.

Technology	LT PEM FC
Common size	1-100 kW
Fuel	Hydrogen
Emission	-
Efficiency	50 - 60 %

All fuel cell systems neither produce SO₂, fine dust particles nor soot. They usually have between 10,000 and 20,000 operating hours, but the fuel cell providers are currently aiming for 30,000 h.

Energy sources

Various energy sources can be used as fuel for fuel cells. Often hydrogen, methanol or natural gas is used as basis for the electrolytic process as shown in Figure 29.

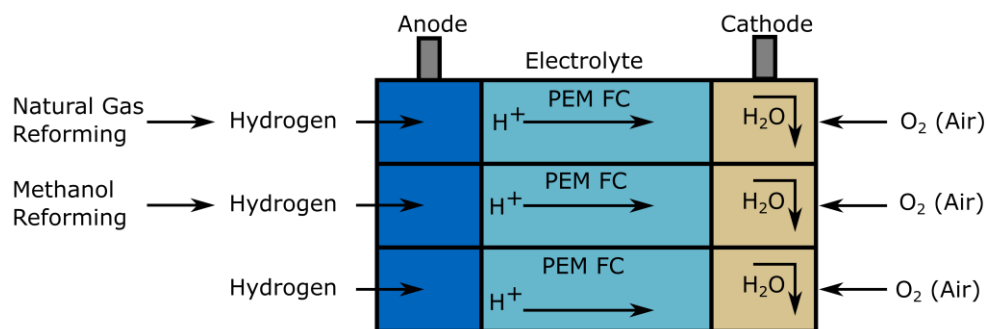

Figure 29: Electrolytic process based on hydrogen, methanol or natural gas

Components on board

The fuel cell system as a propulsion system for a ship often consists of several components. These include the fuel cell, an electric motor, accumulators and partly a reformer. A negative property of the fuel cell is its own inertia to react. This inertia is balanced by an accumulator. It must also be taken into account that a fuel cell needs some time to reach operating temperature, this time difference is also compensated by the accumulator. The fuel cell supplies direct current, the energy produced is transmitted to an electric motor for propulsion. This electric motor, for example, generates the rotary motion for the propeller shaft. The energy requirements for all electrical equipment on board a ship can be supplied directly from the fuel cell or accumulator without detours. The arrangement of the fuel cell and the accumulator can be either parallel or in series.

Hydrogen system for a PEM FC

The hydrogen's high pressure in the tank (1) is lowered to an amount suitable for the fuel cell (3) in the pressure reduction unit (2). The hydrogen is then fed into the fuel cell.

The voltage of the electric current produced is transformed into the usual on-board voltage by the voltage transformer (4).

The reaction heat is emitted in a separate heat exchanger system (5).

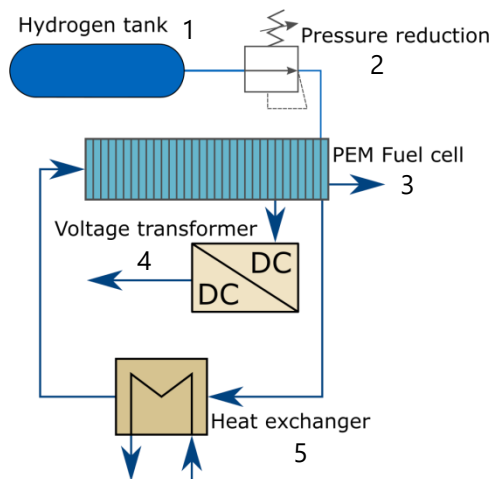

Figure 30: General schema of the Hydrogen system

Methanol system for a HT PEM FC

From the methanol tank (1) the fuel is taken to the reformer unit (3) to extract the hydrogen from it. The process needs heat which is produced by burning an amount of methanol in the heater (2). The pure hydrogen is then fed in the fuel cell (4). Some of the reaction heat in the fuel cell is fed back in the reformer. The remaining heat is emitted in a separate heat exchanger system (6). The voltage of the electric current produced is transformed into the usual on-board voltage by the voltage transformer (5).

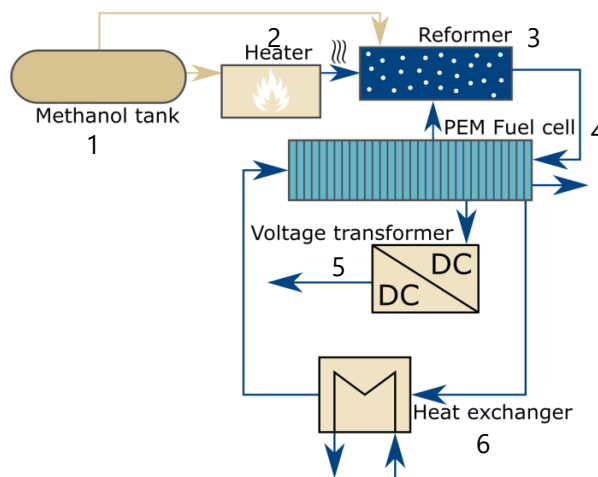

Figure 31: General schema of the Methanol system

3.4 Energy efficiency

Besides the changes in the drive train technologies, also the basic measure of increase of efficiency and reduction of fuel consumption should not be underestimated. Within the past decades the hydrodynamic efficiency of ships has been improved significantly. Ships built in the 1960s and 1970s have about 20 to 25 % higher power demands at the same speed than a new ship. Ships from the 1980s and later still leave about 10 % room for improvements.

Besides the ship design also operation has to be considered. The power demand rises disproportionately with speed and also with decreasing water depth. Accepting 10 % more sailing time compared to the minimum time attainable at full throttle allows up to 30 % reduced fuel consumption [30]. Even maintaining the same sailing time between origin and destination many stretches allow significant fuel savings by means of so-called smart steaming, i.e. the optimized choice of track and speed according to the local waterway conditions. Also, smooth steering with minimized rudder activity helps to increase the speed with a given power.

Rising awareness for energy efficient navigation amongst the boat masters and scheduling staff, known as smart steaming can have a positive effect on fuel saving. The effect enlarges with the amount of details known about the topology of the waterway and flow data.

4 Cost figures and predictions

In this section the investment costs (CAPEX) and operational costs (OPEX) of the above described technologies are identified. A differentiation into current costs and expected future costs has been made. The data presented were derived from desk-research supported by some expert knowledge.

The development of costs between 2020, 2035 and 2050 is assumed to be linear. Extreme price drops at certain points in time are not assumed, as these cannot be specified or the sources present data that differ so greatly from each other that they cannot be reconciled. Also, these jumps in the predictions depend on so many soft factors that they are difficult to quantify. However, the twists and turns that a change in these soft factors would produce are too great an influence on the change in costs. Therefore, these jumps have been omitted as they are too speculative.

An example of an assumed technological leap is the breakthrough of carbon capture and storage technologies without the direct use of the captured CO₂. Previous pilot applications show that the technology is not mature and that especially the storage of CO₂ under the seabed (e.g. under the Sleipner field), is difficult to control. Moreover, the technology is energy-intensive. Developments to date show that even meeting today's energy requirements with renewable energies is a major challenge. Major price drops from such a vague prediction relying on so many factors are not taken into account.

A good example for the price development is the evolution of battery prices. In recent years, the price has fallen sharply due to increasing demand and technological leaps, especially in the automotive industry. Looking at the development, it becomes clear that the price decreases are slowing down. The heavy-duty battery suitable for inland waterway vessels has undergone a similar development, but is still at a higher price level. In the assumed price development scenario in this study, the price of heavy-duty batteries for inland waterway vessels now follows the development in the automotive sector, but more slowly and at a higher level. In general, it is assumed that prices in inland navigation follow those of other modes of transport and energy consumers and are not themselves indicative. The same applies to the further development of individual technologies or would also apply to the breakthrough of a technology: The development of technologies for inland navigation follows the global development and is not leading.

Exemplary references used for the cost figures are linked in the bibliography. Many more sources were analysed and used to check plausibility. Furthermore, there are sources marked as "expert consultation". This information then comes from manufacturers and users in the industry or is in-house knowledge.

4.1 Investment

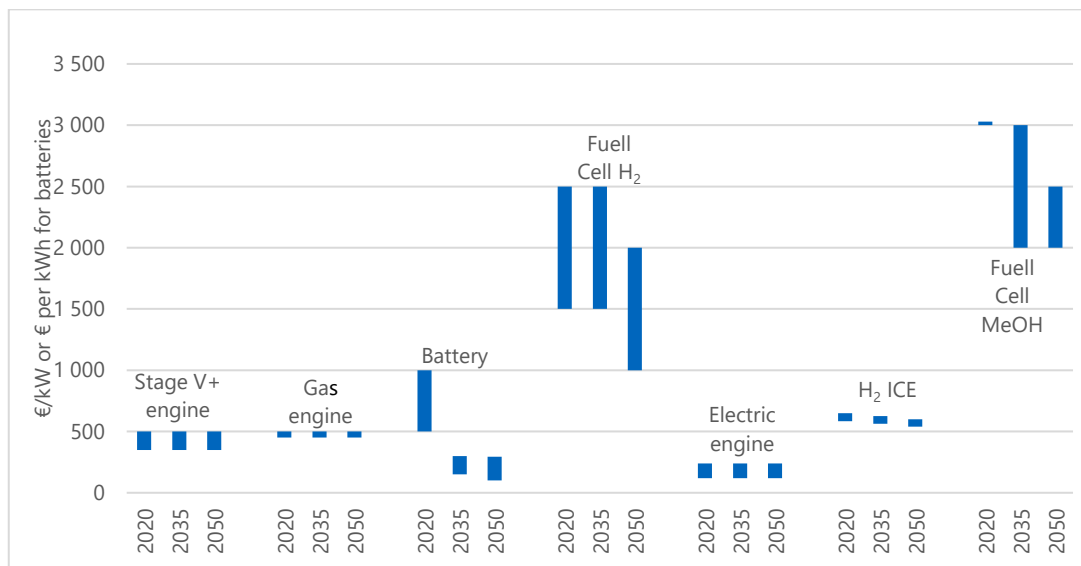

Figure 32: Investment costs per kW for the different energy converters

Assumptions:

Battery	The price development is oriented towards the one for automotive light duty batteries. In 2020, the heavy-duty battery has a price between 700 and 1,000 €/kWh, which is a factor of 6 to 8.5 compared to the light duty battery. For the light duty, the prices shall drop significantly in 2035 and 2050. It is assumed that the factor compared to heavy-duty will then be between 2.0 and 3.5. [31] [32] [33]										
Electric Engine	The electric engine is a well-proven technology. Price drops over time are not assumed, but a variance in the prices of 25 %. [expert consultation]										
H ₂ Fuel Cell	The H ₂ FC will receive a price reduction in 2050. In general, scaling according to installed capacity is carried out here (scaling effects), which is as follows [expert consultation]: <table border="1" style="margin-left: 20px;"> <thead> <tr> <th>2020 and 2035:</th> <th>2050:</th> </tr> </thead> <tbody> <tr> <td>< 500 kW: 2,500 €/kW</td> <td>< 500 kW: 2,000 €/kW</td> </tr> <tr> <td>500 – 1,500 kW: 2,000 €/kW</td> <td>500 – 1,500 kW: 1,500 €/kW</td> </tr> <tr> <td>1,500 – 5,000 kW: 1,500 €/kW</td> <td>1,500 – 5,000 kW: 1,000 €/kW</td> </tr> <tr> <td>> 5,000 kW: 1000 €/kW</td> <td>> 5,000 kW: 750 €/kW</td> </tr> </tbody> </table>	2020 and 2035:	2050:	< 500 kW: 2,500 €/kW	< 500 kW: 2,000 €/kW	500 – 1,500 kW: 2,000 €/kW	500 – 1,500 kW: 1,500 €/kW	1,500 – 5,000 kW: 1,500 €/kW	1,500 – 5,000 kW: 1,000 €/kW	> 5,000 kW: 1000 €/kW	> 5,000 kW: 750 €/kW
2020 and 2035:	2050:										
< 500 kW: 2,500 €/kW	< 500 kW: 2,000 €/kW										
500 – 1,500 kW: 2,000 €/kW	500 – 1,500 kW: 1,500 €/kW										
1,500 – 5,000 kW: 1,500 €/kW	1,500 – 5,000 kW: 1,000 €/kW										
> 5,000 kW: 1000 €/kW	> 5,000 kW: 750 €/kW										
Fuel Cell MeOH	The Methanol fuel cell prices include the on-board reformer system. The integrated reformer ensures a consistently high										

	hydrogen quality. The high price therefore results from the complexity of the system. It is assumed that from 2035 to 2050 a learning curve will lower the price [34].
Gas engine	The gas engine, whether as a pure or dual-fuel engine, is a mature technology that does not assume significantly lower prices. A price variance of 10 % is assumed [expert consultation].
Stage V	<p>The Stage V engine, representative of all future emission standards, is a technically mature diesel engine. Therefore, a constant price variance is assumed here, but not a significantly decreasing average price.</p> <p>Funding is considered to be already existing and investments to be placed within the usual framework of periodic replacements. Therefore, the costs for this kind of engines are not added to the price of measures to reach the 2050 goal [expert consultation].</p>
H ₂ ICE	The H ₂ internal combustion engine is not ready for mass production yet. Nonetheless it is based on the mature technology of the internal combustion engine. A price variance of 10 % and a learning curve will lower the price over time steps 2035 and 2050 [expert consultation].

For the installation of the new technologies some base prices were assumed. These include the baseline prices.

Electrification base price	350,000 € to 850,000 €	The price is dependent on the amount of changes that need to be made towards an electric drive system. Major conversions such as an exchange of the whole aft ship are not included [expert consultation].
LNG-System base price	1,100,000 €	LNG tank, Tank control system, wiring, piping, etc. [expert consultation].
Installation Diesel engine	20,000 €	[expert consultation]
Installation H ₂ engine	50,000 €	[expert consultation]

The prices for electrification and an LNG system are including all installation costs and the hardware like the LNG tank, TCS, wiring, piping, etc., except for respective electric motors, batteries or gas engines.

Diesel-electric and DPF + SCR

Diesel-electric system	Gensets	350 €/kW
	Electric motor	120 €/kW
	Installation costs	30,000 € for conversion, wiring and power management [expert consultation]
DPF and SCR	DPF: 25,000 € + 100 €/kW installed SCR: 25,000 € + 100 €/kW installed → Here: 25,000€ + 200 €/kW	[expert consultation]

Operating costs:

Maintenance	6,000 – 10,000 €/year
AdBlue® consumption	approximately 5 % of fuel consumption
AdBlue® costs	0.20 - 0.50 €/l which is approximately 25 €/1,000 l diesel [expert consultation]

4.2 Capital Costs and depreciation

The weighted average costs of capital are assumed to be 6 %. This is based on a Cost of Capital Study [35] and represents the mean value and a linear depreciation. This assumption is especially for some old vessels (already written off) still optimistic, as banks will be reluctant to make a major investment. The total service life of the systems is assumed to be 20 years. The new price is therefore depreciated over this period. However, there is a not negligible reinvestment in batteries and fuel cells, namely when the cells or membranes have to be replaced. These are allocated to the OPEX costs.

4.3 Operational costs

Operational costs are an important factor in the use of new zero-emission technologies. Most fuels are, at least at present, more expensive up to significantly more expensive than conventional diesel.

Related to certain aspects maintenance costs will grow as with the new technologies the level of complexity of the system in most cases will increase. Special system conditions like working with high pressure or cryogenic system components contribute to this situation compared to a simple and well-known diesel engine. This will make it

more difficult to maintain the system by themselves without advanced education or even special tools and often software applications. Out of different discussions, amongst others consultation with manufacturers and based on in-house knowledge this has led to the adoption of an average of 10% per year of the initial investment for maintenance costs. This is considering that there is less maintenance for electric drives compared to conventional drivetrains. At the same time it is taken into account that less can be done by the crew and for some technologies the maintenance costs apply on a regular basis while others require significant reinvestment after a longer period e.g. for the exchange of cells or membrane-assemblies, also included within the 10 %. For further information on maintenance costs see section 4.5.

4.4 Fuels

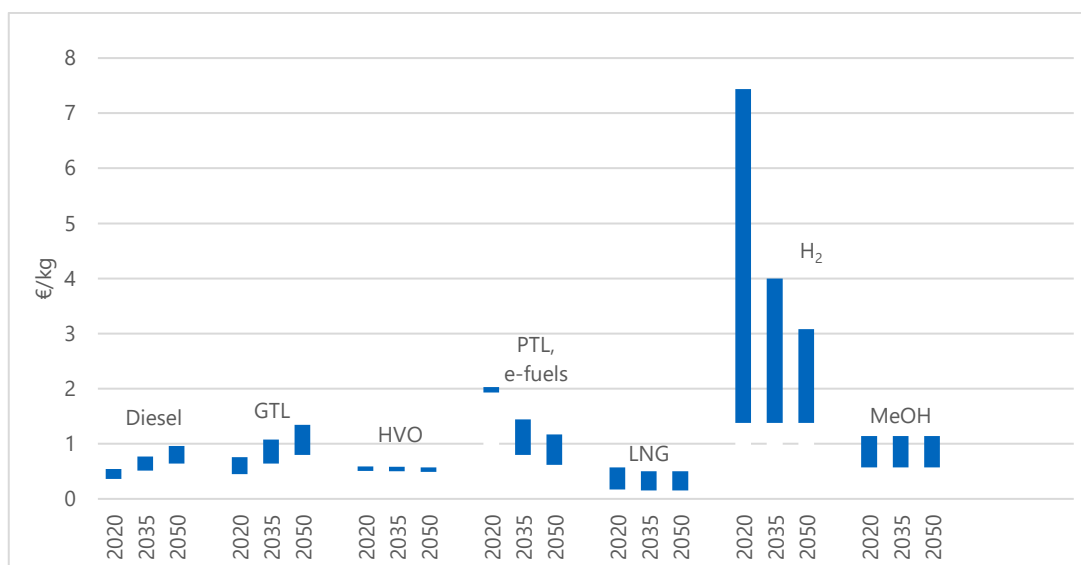

Figure 33: Operational costs per kg for different energy carriers

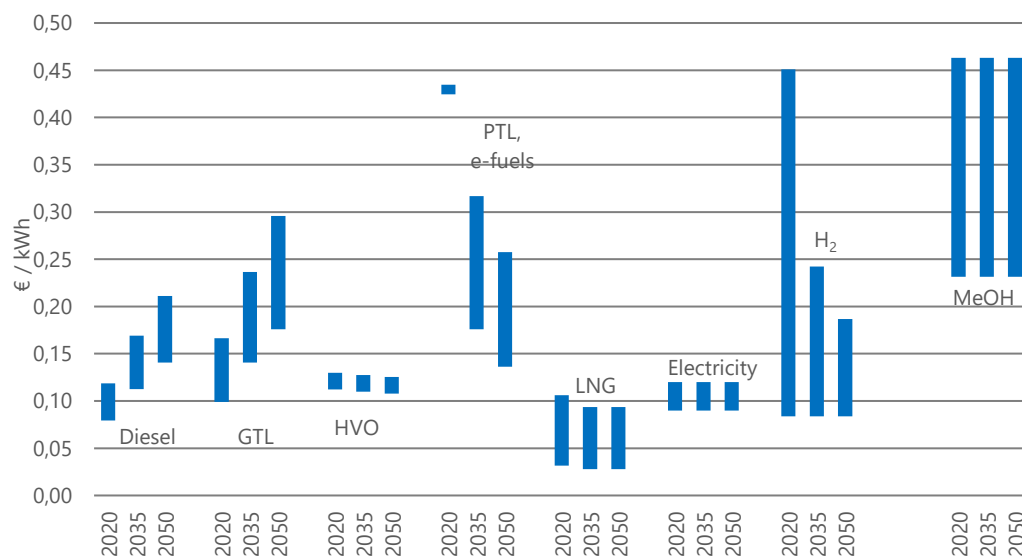

Figure 34 Operational costs per kWh for different energy carriers

The bandwidths in Figure 34 result from the different sources. In some cases, the predictions for the maximum are optimistic, the minimum remains the same. The apparent accuracy for future predictions is therefore only obtained by limiting the maximum.

GTL	GTL price development: medium-term rising price levels are assumed followed by decreasing costs later according to [36].
HVO	The deviating scenario, measured against source forecasts, is based on the assumption that there are no production bottlenecks caused by rising demand, which would be reflected in rising costs, and that sufficient capacity is made available for shipping from the quantities available. Learning effects are also considered [22] [37] [38] [21] [39]. Other than for Diesel there is no CO ₂ tax assumed.
PTL, e-fuels	The prices for pure e-fuels from Power-to-X plants remain high compared to other diesel-like fuels. There is a price drop in 2035 since by then the first larger-scale production is starting [36], [40], [6] [41].
LNG	The LNG price has a slight drop in 2035. The spot-market prices are derived from the world energy outlook (WEO) scenarios. Assumption: The LNG bunker price is three times as high as the worldwide wholesale price [19] [42].
Electricity	The electricity price scenarios are the same for all three dates. The minimum of 3 ct/kWh is kept since this is assumed to be the reasonable lowest power generation costs [43].
Hydrogen (H ₂)	The price for hydrogen with a sufficient purity has a price drop in 2035. Then the production of electrolysis is assumed to rise and lead to dropping prices [19], [44], [10].
Diesel	The diesel price is derived from the world energy outlook WEO2019 stated policies scenario [45].
MeOH	MeOH is more and more blended with renewable parts towards 2050. The price of fossil MeOH is dropping, renewable MeOH prices are also assumed to lower, but are higher compared to the fossil source. The changing blend will

therefore be kept at the same price level
[46] [23].

4.5 Maintenance

Experience from the automotive sector shows that a battery or fuel cell system tends to require less maintenance than combustion engines. However, on inland waterway vessels, many maintenance tasks have so far been carried out by the vessel's own personnel, which reduced maintenance costs by the price of hiring service technicians. The complexity of the new technologies, on the other hand, means that a service technician almost always has to be hired, which increases the price of maintenance costs. There is also hardly any experience so far as of the long-term use of new zero-emission technologies on inland waterway vessels, so that no reliable estimate of maintenance costs is possible based on empirical values. After balancing both scenarios and taking into account amongst others consultation with manufacturers it is now assumed that both types of systems can be estimated with maintenance costs of 10 % per year. For batteries and fuel cells this includes the reinvestment for new cells or membrane-assemblies that is due after a certain operating period. For batteries the life time depends on many factors like e.g. chemistry, depth of discharge and C-rate. The assumed life span for batteries taken into account was decided to be 8 years. For FC 25,000 hours are envisaged as per MariGreen, a H₂ study that pursues the objective of an integrated approach to the implementation of GreenShipping technologies and developments [10]. As there is not sufficient experience yet this could change within the coming years.

Here it is assumed that 10 % p.a. of the initial investment for battery cells or fuel cells must be saved over the depreciation period of 20 years in order to make the reinvestment. This is a normal depreciation period required by the shipping companies for accounting reasons and also based on the fact that especially for small shipping companies, according to the consulted shipowners, the investment could not otherwise be raised.

The additional costs for the AdBlue consumption of the SCR system described in section 4.1 are also included within the 10 % p.a. of maintenance costs in case of ICE systems.

5 Fleet Families

Summarizing the information presented above, the proposed fleet families used for the analysis are as listed hereafter:

- **Passenger vessels** (large hotel)
- **Push boats < 500 kW** (total propulsion power)
- **Push boats 500 - 2,000 kW** (total propulsion power)
- **Push boats \geq 2,000 kW** (total propulsion power)
- **Motor vessels dry cargo \geq 110 m length**
- **Motor vessels liquid cargo \geq 110 m length**
- **Motor vessels dry cargo 80 - 109 m length**
- **Motor vessels liquid cargo 80 - 109 m length**
- **Motor vessels < 80 m length**
- **Coupled convoys** (mainly class Va + Europe II lighter)
- **Ferries**
- **Daytrip and small hotel vessels**

The numbers for the categories “Passenger vessels (large hotel), “Ferries” and “Daytrip and small hotel vessels” were derived from the IVR database.

5.1 Main characteristics of the fleet families

The table below gives some information on the main characteristics of the fleet families. It is important to know the specific characteristics of the fleet families in order to assign zero-emission technologies to them as appropriate as possible.

In addition, the energy demand gives an indication which technologies are suitable for the different fleet families. However, this is not the only factor to base the decision upon.

Table 7: Description of the fleet families

Fleet Families	Description
Passenger vessels (large hotel)	<ul style="list-style-type: none"> • High energy demand for hotel load
Push boats < 500 kW (total propulsion power)	<ul style="list-style-type: none"> • Moderate energy demand
Push boats 500 - 2,000 kW (total propulsion power)	<ul style="list-style-type: none"> • High energy demand
Push boats \geq 2,000 kW (total propulsion power)	<ul style="list-style-type: none"> • High energy demand
Motor vessels dry cargo \geq 110 m length	<ul style="list-style-type: none"> • High energy demand • Heterogeneous age • The amount of coal transported may sink

Motor vessels liquid cargo \geq 110 m length	<ul style="list-style-type: none"> • High energy demand • Younger vessels (double hull regulation in 2008)
Motor vessels dry cargo 80 – 109 m length	<ul style="list-style-type: none"> • High energy demand • Heterogeneous age
Motor vessels liquid cargo 80 – 109 m length	<ul style="list-style-type: none"> • High energy demand • Younger vessels (double hull regulation in 2008)
Motor vessels < 80 m length	<ul style="list-style-type: none"> • Moderate energy demand • Limited space on board
Coupled convoys (mainly class Va + Europe II lighter)	<ul style="list-style-type: none"> • High energy demand
Ferries	<ul style="list-style-type: none"> • Fixed short route • Fixed schedule
Day trip and small hotel vessels	<ul style="list-style-type: none"> • Short trips • Sailing area limited • Fixed routes and berths • Fixed schedule

Table 8: Average fuel consumption of the main fleet families per vessel per year (based on detailed information from Western-European countries)

Fleet families	Average annual fuel consumption [m ³]	Average total engine power installed [kW]
Passenger vessels (large hotel)	350	750
Push boats < 500 kW	22	185
Push boats 500 – 2,000 kW	110	635
Push boats \geq 2,000 kW	1,449	2,594
Motor vessels dry cargo \geq 110 m	237	1,307
Motor vessels liquid cargo \geq 110 m	240	1,335
Motor vessels dry cargo 80 – 109 m	113	573
Motor vessels liquid cargo 80 – 109 m	166	716
Motor vessels < 80 m	34	227
Coupled convoys	391	1,678
Ferries	69	281
Day trip and small hotel vessels	38	375

5.2 Fleet development

For the analysis, the development of the fleet until 2050 also had to be mapped. For this purpose, it was assumed that the age structure of the fleet would remain similar to what was presented in the IVR vessel database for 2015 [2]. The values for the fleet families determined for 2015 were used as a starting point for 2020. Vessels above a certain age

will be decommissioned. This means that the corresponding age varies per fleet family in relation to [2] and for the future development of the fleet, vessels are decommissioned in a way that the fleet composition is maintained, including the age structure. 95 % of the decommissioned vessels are replaced which is following a trend as per CCNR market observations [47]. Only the hotel/cruise vessels have a 100 % newbuilt rate. As they are decommissioned at around 30 years of age, it is expected to have a fleet family whose oldest members in 2050 will be built not long before 2020.

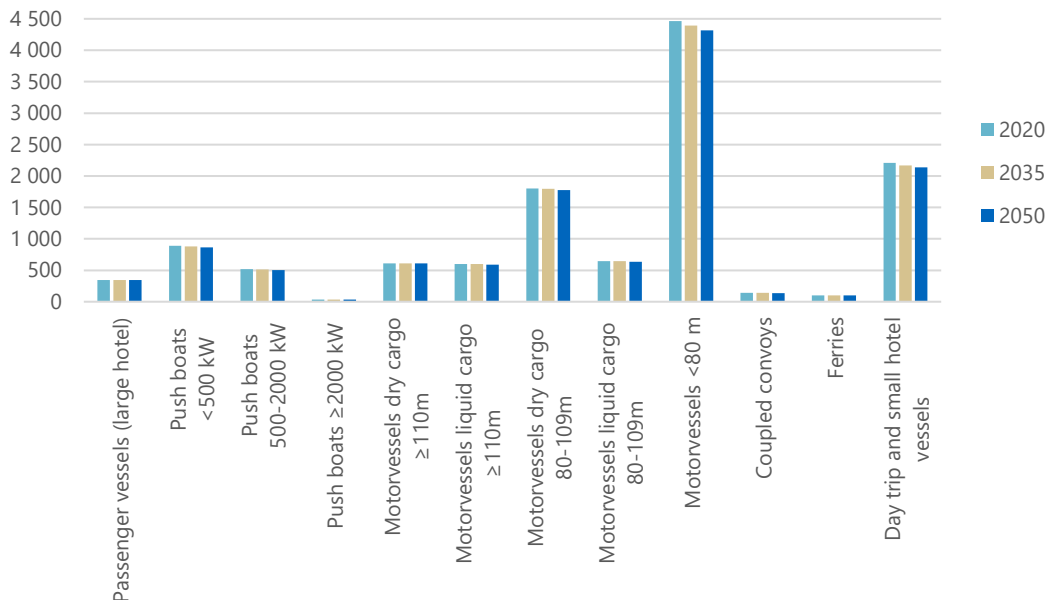

Figure 35: Development of the fleet from 2020 to 2050 - maintaining the original age structures within the fleet families

5.3 Technologies differentiated to the fleet families

The table presented below shows the technologies assigned to the fleet families. They are all evaluated according to the criteria TRL, volume, weight, costs, range and emission reduction potential for the respective fleet family. Selected decisions are explained below the table. To keep the level of complexity as low as possible only few colours are chosen to illustrate the rating of the criteria. That does not mean that LNG is as good as HVO related to their emission reduction potential (compare also section 3.2) but they are both better than diesel and worse than zero-emission technologies and therefore get the rating “yellow”. One criterion can also change the colour from one fleet family to the next as the rating additionally includes how the specific fleet family is able to handle the fact that for example batteries take up quiet some space and are heavy. Therefore, the same criteria might be red for one fleet family member as it depicts almost an exclusion while it is rated yellow for another fleet family as the battery stays big but anyhow there are possibilities to make the technology fit. To stay with the example, for the next case the energy demand might be less so that a battery despite the restricted space of that fleet family is suitable for the application and nevertheless gets the rating “yellow” for volume. This shall give an idea on how the colours were chosen

without going too much into detail as this would go beyond the scope of what is the intention to be shown with the table below.

Besides, it must be borne in mind that the type ships each represent the average value of a fleet family. This means that vessels with significantly smaller or even significantly larger installed capacities and energy consumption are located at the edges of the fleet families. The sailing area and the profile are very important factors in inland navigation. A technology selected for the type ship may not appear optimal, but for individual members of the fleet family it might be a very good solution. These particular constraints have been taken into account as far as possible in the allocation of technologies to fleet families.

Examples are vessels that sail a considerable time in the canal and therefore often have low energy and power requirements. Another example are vessels that operate in a liner service along a certain, constant route.

Table 9: Selection criteria for technologies per fleet family

Fleet family	Technology	Selection criteria						
Passenger vessels (large hotel)		TRL	Volume	Weight	CAPEX	OPEX	Range	Em. Red.
	Battery	Green	Red	Red	Yellow	Green	Red	Green
	H ₂ FC	Green	Red	Green	Yellow	Yellow	Yellow	Green
	MeOH FC	Yellow	Green	Green	Yellow	Green	Green	Green
	LNG	Green	Yellow	Green	Yellow	Green	Green	Yellow
	H ₂ ICE	Yellow	Red	Green	Yellow	Yellow	Yellow	Yellow
	Stage V GTL	Green	Green	Green	Green	Green	Green	Red
	Stage V HVO	Green	Green	Green	Green	Green	Green	Yellow
	Stage V PTL	Yellow	Green	Green	Green	Yellow	Green	Yellow

Fleet family	Technology	Selection criteria						
Push boats < 500 kW		TRL	Volume	Weight	CAPEX	OPEX	Range	Em. Red.
	Battery	Green	Yellow	Yellow	Yellow	Green	Yellow	Green
	H ₂ FC	Green	Red	Green	Yellow	Yellow	Yellow	Green
	MeOH FC	Yellow	Green	Green	Yellow	Green	Green	Green
	LNG	Green	Red	Red	Yellow	Green	Green	Yellow
	H ₂ ICE	Yellow	Yellow	Yellow	Yellow	Yellow	Yellow	Yellow
	Stage V GTL	Green	Green	Green	Green	Green	Green	Red
	Stage V HVO	Green	Green	Green	Green	Green	Green	Yellow
	Stage V PTL	Yellow	Green	Green	Yellow	Yellow	Green	Yellow

Fleet family	Technology	Selection criteria						
Push boats 500 – 2,000 kW		TRL	Volume	Weight	CAPEX	OPEX	Range	Em. Red.
	Battery	Green	Yellow	Red	Yellow	Green	Red	Green
	H ₂ FC	Green	Red	Green	Yellow	Yellow	Yellow	Green
	MeOH FC	Yellow	Green	Green	Yellow	Green	Green	Green
	LNG	Green	Red	Red	Yellow	Green	Green	Yellow
	H ₂ ICE	Yellow	Yellow	Yellow	Yellow	Yellow	Yellow	Yellow
	Stage V GTL	Green	Green	Green	Green	Green	Green	Red
	Stage V HVO	Green	Green	Green	Green	Green	Green	Yellow
	Stage V PTL	Yellow	Green	Green	Yellow	Yellow	Green	Yellow

Fleet family	Technology	Selection criteria						
		TRL	Volume	Weight	CAPEX	OPEX	Range	Em. Red.
Push boats ≥ 2,000 kW								
	Battery	Green	Yellow	Red	Red	Green	Red	Green
	H ₂ FC	Green	Red	Green	Yellow	Yellow	Yellow	Green
	MeOH FC	Yellow	Green	Green	Yellow	Green	Green	Green
	LNG	Green	Yellow	Green	Yellow	Green	Yellow	Yellow
	H ₂ ICE	Yellow	Yellow	Yellow	Yellow	Yellow	Yellow	Yellow
	Stage V GTL	Green	Green	Green	Green	Green	Green	Red
	Stage V HVO	Green	Green	Green	Green	Green	Green	Yellow
	Stage V PTL	Yellow	Green	Green	Yellow	Yellow	Green	Yellow

Fleet family	Technology	Selection criteria						
		TRL	Volume	Weight	CAPEX	OPEX	Range	Em. Red.
Motor vessel dry cargo ≥ 110 m								
	Battery	Green	Yellow	Yellow	Yellow	Green	Yellow	Green
	H ₂ FC	Green	Red	Green	Yellow	Yellow	Yellow	Green
	MeOH FC	Yellow	Green	Green	Yellow	Green	Green	Green
	LNG	Green	Yellow	Green	Yellow	Green	Yellow	Yellow
	H ₂ ICE	Yellow	Yellow	Yellow	Yellow	Yellow	Yellow	Yellow
	Stage V GTL	Green	Green	Green	Green	Green	Green	Red
	Stage V HVO	Green	Green	Green	Green	Green	Green	Yellow
	Stage V PTL	Yellow	Green	Green	Yellow	Yellow	Green	Yellow

Fleet family	Technology	Selection criteria						
		TRL	Volume	Weight	CAPEX	OPEX	Range	Em. Red.
Motor vessel liquid cargo ≥ 110 m								
	Battery	Green	Yellow	Yellow	Yellow	Green	Yellow	Green
	H ₂ FC	Green	Red	Green	Yellow	Yellow	Yellow	Green
	MeOH FC	Yellow	Green	Green	Yellow	Green	Green	Green
	LNG	Green	Yellow	Green	Yellow	Green	Yellow	Yellow
	H ₂ ICE	Yellow	Yellow	Yellow	Yellow	Yellow	Yellow	Yellow
	Stage V GTL	Green	Green	Green	Green	Green	Green	Red
	Stage V HVO	Green	Green	Green	Green	Green	Green	Yellow
	Stage V PTL	Yellow	Green	Green	Yellow	Yellow	Green	Yellow

Fleet family	Technology	Selection criteria						
		TRL	Volume	Weight	CAPEX	OPEX	Range	Em. Red.
Motor vessel dry cargo 80 - 109 m								
	Battery	Green	Yellow	Yellow	Yellow	Green	Yellow	Green
	H ₂ FC	Green	Red	Green	Yellow	Yellow	Yellow	Green
	MeOH FC	Yellow	Green	Green	Yellow	Green	Green	Green
	LNG	Green	Yellow	Green	Yellow	Green	Yellow	Yellow
	H ₂ ICE	Yellow	Yellow	Yellow	Yellow	Yellow	Yellow	Yellow
	Stage V GTL	Green	Green	Green	Green	Green	Green	Red
	Stage V HVO	Green	Green	Green	Green	Green	Green	Yellow
	Stage V PTL	Yellow	Green	Green	Yellow	Yellow	Green	Yellow

Fleet family	Technology	Selection criteria						
		TRL	Volume	Weight	CAPEX	OPEX	Range	Em. Red.
Motor vessel liquid cargo 80 - 109 m								
	Battery	Green	Yellow	Yellow	Yellow	Green	Yellow	Green
	H ₂ FC	Green	Red	Green	Yellow	Yellow	Yellow	Green
	MeOH FC	Yellow	Green	Green	Yellow	Green	Green	Green
	LNG	Green	Yellow	Green	Yellow	Green	Yellow	Yellow
	H ₂ ICE	Yellow	Yellow	Yellow	Yellow	Yellow	Yellow	Yellow
	Stage V GTL	Green	Green	Green	Green	Green	Green	Red
	Stage V HVO	Green	Green	Green	Green	Green	Green	Yellow
	Stage V PTL	Yellow	Green	Green	Yellow	Yellow	Green	Yellow

Fleet family	Technology	Selection criteria						
		TRL	Volume	Weight	CAPEX	OPEX	Range	Em. Red.
Motor vessels < 80 m								
	Battery	Green	Yellow	Yellow	Yellow	Green	Yellow	Green
	H ₂ FC	Green	Red	Green	Yellow	Yellow	Yellow	Green
	MeOH FC	Yellow	Green	Green	Yellow	Green	Green	Green
	LNG	Green	Yellow	Green	Yellow	Green	Yellow	Yellow
	H ₂ ICE	Yellow	Yellow	Yellow	Yellow	Yellow	Yellow	Yellow
	Stage V GTL	Green	Green	Green	Green	Green	Green	Red
	Stage V HVO	Green	Green	Green	Green	Green	Green	Yellow
	Stage V PTL	Yellow	Green	Green	Yellow	Yellow	Green	Yellow

Fleet family	Technology	Selection criteria						
		TRL	Volume	Weight	CAPEX	OPEX	Range	Em. Red.
Coupled convoys								
	Battery	Green	Yellow	Yellow	Yellow	Green	Yellow	Green
	H ₂ FC	Green	Red	Green	Yellow	Yellow	Yellow	Green
	MeOH FC	Yellow	Green	Green	Yellow	Green	Green	Green
	LNG	Green	Yellow	Green	Yellow	Green	Green	Yellow
	H ₂ ICE	Yellow	Yellow	Yellow	Yellow	Yellow	Yellow	Yellow
	Stage V GTL	Green	Green	Green	Green	Green	Green	Red
	Stage V HVO	Green	Green	Green	Green	Green	Green	Yellow
	Stage V PTL	Yellow	Green	Green	Yellow	Yellow	Green	Yellow

Fleet family	Technology	Selection criteria						
		TRL	Volume	Weight	CAPEX	OPEX	Range	Em. Red.
Ferries								
	Battery	Green	Yellow	Yellow	Yellow	Green	Green	Green
	H ₂ FC	Green	Yellow	Green	Yellow	Yellow	Green	Green
	MeOH FC	Yellow	Green	Green	Yellow	Green	Green	Green
	LNG	Green	Yellow	Yellow	Red	Yellow	Green	Yellow
	H ₂ ICE	Yellow	Yellow	Yellow	Yellow	Yellow	Green	Yellow
	Stage V GTL	Green	Green	Green	Green	Green	Green	Red
	Stage V HVO	Green	Green	Green	Green	Green	Green	Yellow
	Stage V PTL	Yellow	Green	Green	Yellow	Yellow	Green	Yellow

Fleet family	Technology	Selection criteria						
		TRL	Volume	Weight	CAPEX	OPEX	Range	Em. Red.
Day trip and small hotel vessels								
	Battery	Green	Yellow	Yellow	Yellow	Green	Green	Green
	H ₂ FC	Green	Yellow	Green	Yellow	Yellow	Green	Green
	MeOH FC	Yellow	Green	Green	Yellow	Green	Green	Green
	LNG	Green	Yellow	Yellow	Red	Yellow	Green	Yellow
	H ₂ ICE	Yellow	Yellow	Yellow	Yellow	Yellow	Green	Yellow
	Stage V GTL	Green	Green	Green	Green	Green	Green	Red
	Stage V HVO	Green	Green	Green	Green	Green	Green	Yellow
	Stage V PTL	Yellow	Green	Green	Yellow	Yellow	Green	Yellow

Additional information on the choices made:

- For vessels that are still driven by a combustion engine burning fossil fuel in 2050 it is assumed that at least a stage V engine is installed or measures are taken to reach equivalent emission limits. LNG contributes to CO₂ reduction but is still emitting GHG [25].
- For LNG it should be noted that the high initial costs to changeover to this fuel are only viable for vessels with high fuel consumption. Based on lower costs per kWh LNG systems would allow acceptable amortisation times. In addition, the expenses only remain acceptable for larger fleets or shipowners not operating only one ship. This is presumed to be fulfilled for some coupled convoys, as well as some motor vessels for dry and liquid cargo of 110 m in length and above and some large push boats.
- Bio-methane is not expected to play a significant role in the future. Fossil gas is liquefied for the transport with sea-going ships from gas sources, which are too remote for pipelines. Therefore, it is available as LNG in many sea ports with a hinterland connection to the inland waterways. For sea-going ships there is a business case to use LNG as they benefit from the bunkering infrastructure and the high energy throughput. In addition, the emissions are reduced as maritime fuels still contain more sulphur. Inland vessels however require more or less the same expensive hardware but have less energy demand to allow amortisation. The investment for the hardware also hinders the use of liquefied bio-methane. When fuel is produced from biomass and/or renewable energy, it is more likely to favour fuels with easier handling and less challenges like methane slip [48].
- Due to its range batteries are not suitable for vessels with high energy demand like hotel and cruise vessels as well as large push boats. In addition, large push boats often operate 24/7 and have therewith no room in their operational profile to get recharged. For smaller push boats with lesser energy demands the operation profile is considered to match with charging cycles for part of the fleet.
- For the fuel cell (FC) the floor space is critical. However, example projects like 'ELEKTRA' demonstrate the practicability for pushers though coupled with a drastic reduction of the deckhouse. To reach the zero-emission target at all creative solutions remain necessary especially in combination with existing vessel configurations.
- Main advantages of the methanol FC compared to hydrogen is the less critical handling without cryogenic or high-pressure technology and the lower fuel price. Therefore, a reformer is needed in addition which for hotel and cruise vessels has the advantage that produced process heat finds multiple applications. The larger volumetric requirements to store hydrogen makes it more

attractive to be used by ships with shorter ranges like daytrip vessels also having the possibility to bunker more frequently and always at the same location.

- The H₂ internal combustion engine (ICE) has not yet reached a technological readiness level for a broad application. Only for ferries there is an application example currently being developed.

5.3.1 Exemplarily type ships per fleet family

In this section one exemplary advanced and clean solution per fleet family is presented. The selection is based on the criteria listed above (section 5.3). However, the concept of the fleet families is a practical but simplifying approach. In principle, every ship is different. When vessels are similar in size and cargo and, therefore, bundled in one fleet family, the difference in operating mode and operational profile becomes relevant for the layout of zero-emission technologies. E.g. the power requirement strongly depends on the operating area and the storage capacity of energy (fuel) should match the boundary conditions of bunkering infrastructure, operating mode and required range. Some options may be too heavy for a ship frequently operating in stretches with low water depth, while another option is too voluminous for a ship limited by bridge heights or locks. The cargo or handling facilities of a liquid cargo ship or the safety requirements of a passenger vessel might also limit the use of solutions with higher risks.

Therefore, the ship design in general and the clean drivetrain for both retrofits and newbuilds should be tailored to the transport task and operational profile of the ship. Nevertheless, standardization and modular concepts will play an important role to lower the costs for most clean drivetrain solutions. With stackable fuel cells and batteries, the tailored approach with a strong differentiation of the solutions is not a contradiction with standardization. Compared to the conventional diesel system with moderate costs for fuel and engine combined with the high energy density, some flexibility is lost for the usage of the ship. Still retrofitting zero-emission technologies is complex and requires major conversions in most cases. For cargo vessels replacing the rear hull of an existing ship can be a cost-effective approach to bring older vessels up to date in relatively short docking time with the latest developments including hydro-dynamic improvements, e.g. for operation in low water levels.

However, a tailored system can benefit from significantly lower costs, less losses in cargo space and a higher chance for a return on investment. To gain this cost efficiency the system has to be tailored very much in detail for the exact future use. The examples do not allow this specific consideration to be taken. An averaged scenario is used. This means that the installation costs are approx. 500,000 € per ship.

The installed power for the main propulsion refers to the identified power of the main engine in the PROMINENT project.

A distinction must be made here between several aspects:

- The hydrodynamics efficiency continues to improve with the renewed fleet.

- In the future, energy costs will account for a larger share of the total costs, also motivating the improvement of energy efficiency during operation supported by developments of advice tools (smart navigation, lock scheduling, awareness).
- Current installed engine powers leave some room for right sizing. Also motivated by increasing costs for clean drivetrains.

The resulting assumptions are supported by in-house knowledge based on observations of the development of inland waterway vessels in relation with research and development projects at the DST.

Two important assumptions are made:

- Firstly, it is assumed that the efficiency of ships can be increased by 20 % compared to the PROMINENT fleet families on average.
- Secondly, many of the vessels in the current fleet combined in the PROMINENT evaluation are overpowered for reasons such as the moderate engine costs, longer service intervals for low utilization, increasing flexibility for not yet known applications. Motorization thus leaves room for so-called right sizing.

As a result, only 75 % of the average power of the main propulsion system identified in PROMINENT is assumed here. These assumptions are also presented in Table 8.

Additionally, it is assumed that the vessel will be equipped with systems according to the average price scenario. The price developments refer to the representative year 2042 based on linear interpolation between the numbers for 2035 and 2050. For the presented advanced drive-trains it is not likely that a widespread implementation starts before 2035.

All examples are derived directly from the fleet families and show an average, not an optimized design. This is done to be able to keep up with the fleet family categorisation. The space requirement is only taken into account for hydrogen as this is particularly critical. The examples equipped with H₂ receive an optimized pressure tank which contains reserves for two days. The assumption regarding the two days has been made in order to make the costs comparable. Costs for larger or smaller tanks would be taken into account in a ship-specific design.

The average ship design represents the initial situation before the conversion. Based on this, the new motorization is then provided. All vessels with fuel cells are calculated with hybrid installations since fuel cells are expensive per kilowatt and may have insufficient dynamic performance. 60 % of the previously installed engine power is replaced by the fuel cell. In addition, a battery with a capacity in kWh corresponding to 60 % of the formerly installed engine power is foreseen for peak shaving. This is just an averaged rough estimate. An optimized system will deviate from this based on the operational profile and further details.

Passenger vessels (large hotel)

The large passenger vessels, besides the consumption of the main engine also have a hotel load to serve. The load is expected to be 3.6 MWh per day. For passenger vessels

the advantages of the methanol FC to have a less critical handling without cryogenic or high-pressure technology than with hydrogen is especially important and counts more than for other cargo carriers. Also, the needed reformer is more an advantage for the application on large hotel vessels as there is quite a heat demand anyhow. Therefore, the process heat easily finds multiple applications. The power installed for the hotel load is also included in the calculation below:

Average ship design

Main dimensions	110 m × 10 m × 1.5 m
Main propulsion power	750 kW
Hotel load	3.6 MWh/d
Energy consumption	3.6 MWh/d + 3.6 MWh/d

Exemplarily new system

Electric motor	750 kW
MeOH FC installed	450 kW + 450 kW
Batteries installed	450 kWh + 450 kWh
Weight and space requirement for batteries	9 t weight and 11.9 m ³ space requirement

Cost prognosis main propulsion and hotel load system

MeOH FC system CAPEX	3,509,688€
Capital Costs	105,290 €/a
Depreciation	175,484 €/a
OPEX	1,164,656 €/a
TCO	1,445,432 €/a

Push boats < 500 kW

The power demand per day is rather moderate for this fleet family. Therefore, it is possible to use a hydrogen fuel cell combined with batteries. The batteries also compensate for peak loads. As this specific fleet member will mostly operate in canal systems or port areas the shorter interval for bunkering or respectively charging is expected to be realistic. Even though the required space is critical, with a creative design the use of a fuel cell system is feasible.

For comparison reasons of the cost aspect the push boat presented here is assumed to have H₂ fuel tank for two days regardless of the real application size.

Average ship design

Main dimensions	20 m × 7 m × 1.2 m
Main propulsion power	185 kW
Energy Consumption	463 kWh/d

Exemplarily new system

Electric Motor	185 kW
H ₂ FC installed	111 kW
Batteries installed	111 kWh
Space requirement for pressure tanks	2.3 m ³ for 28 kg H ₂ at 500 bar

Cost prognosis propulsion system

H ₂ FC system CAPEX	836,103 €
Thereof tank system for 2 days	22,452 €
Capital Costs	25,083 €/a
Depreciation	41,805 €/a
OPEX	40,133 €/a
TCO	100,915 €/a

Push boats 500 - 2,000 kW

The push boat with a former installed power of about 635 kW internal combustion engine is equipped with a MeOH fuel cell in combination with a battery as a peak shaving device. Due to the fact that the tank is easier to be included into the vessel's geometry, this technology is less space consuming compared to hydrogen tanks and therefore the favoured technology to be used in this example. In addition, even though the energy and volumetric density is less compared to diesel, it does not lead to a substantially larger tank volume. Furthermore, the OPEX costs are moderate.

Average ship design

Main dimensions	32 m × 11.0 m × 1.6 m
Main propulsion power	635 kW
Energy consumption	1,143 kWh/d

Exemplarily new system

Electric motor	635 kW
MeOH FC installed	381 kW
Batteries installed	381 kWh

Cost prognosis propulsion system

MeOH FC system CAPEX	1,562,853 €
Capital Costs	46,886 €/a
Depreciation	78,143 €/a
OPEX	250,648 €/a
TCO	375,676 €/a

Push boats ≥ 2,000 kW

The representative of the large push boats is equipped with Stage V engines and uses HVO as fuel. As this type of vessel has such a large energy demand, other technologies are not realistic together with the compact size of the vessel itself. Moreover, these vessels only have a minor contribution to the overall fleet emission due to their small number. The use of HVO with regards to air pollutants is therefore justifiable. Key assumption is the use of the best possible available exhaust gas level.

Average ship design

Main dimensions	40 m × 15 m × 1.7 m
-----------------	---------------------

Main propulsion power	2,594 kW
Energy consumption	14,977 kWh/d
Exemplarily new system	
Stage V engine installed	2,594 kW
Cost prognosis propulsion system	
Stage V system CAPEX	1,122,238 €
Capital Costs	33,667 €/a
Depreciation	56,112 €/a
OPEX	730,389 €/a
TCO	804,607 €/a

Motor vessels dry cargo ≥ 110 m

The main characteristics of the representative are based on the large Rhine vessel. The propulsion concept presented here consists of a 100 kW hydrogen fuel cell combined with 5 MWh of batteries. Here the focus is put on the fuel cell as a range extender other than for previous presented concepts having batteries as the range extender. Besides this, the fuel cell could also serve as peak shaving device in case of high load requirements due to uncommonly extensive manoeuvring activities.

The concept presented is foreseen for vessels mostly operating in the tributaries of the rhine and in the canal system. This is the reason that the comparably low power installation is suitable.

Average ship design	
Main dimensions	100 m 11.45 m 2.5 m
Main propulsion power	1,307 kW
Energy consumption	2,453 kWh/d

Exemplarily new system

Electric motor	750 kW
H ₂ FC installed	100 kW
Batteries installed	5 MWh
Space requirement for pressure tanks	25 m ³ for 297 kg H ₂ at 500 bar
Weight and space requirement for batteries	50 t and 18.7 m ³

Cost prognosis propulsion system

H ₂ FC system CAPEX	2,600,476 €
Thereof H ₂ tank system for 2 days	237,846 €
Capital Costs	78,014 €/a
Depreciation	130,024 €/a
OPEX	291,564 €/a
TCO	467,608 €/a

Motor vessels liquid cargo ≥ 110 m

Here the MeOH fuel cell is chosen to give an example of a larger sized vessel being powered by a MeOH fuel cell. Also, here the fact that the tank can be easier included in the vessel's geometry compared to a hydrogen tank, is favourable as less cargo space has to be rededicated.

Average ship design

Main dimensions	100 m 11.45 m 2.5 m
Main propulsion power	1,335 kW
Energy consumption	2,482 kWh/d

Exemplarily new system

Electric motor	1,335 kW
MeOH FC installed	801 kW
Batteries installed	801 kWh
Weight and space requirement for batteries	8 t and 11 m ³

Cost prognosis propulsion system

MeOH FC system CAPEX	2,733,623 €
Capital Costs	82,009 €/a
Depreciation	136,681 €/a
OPEX	536,757 €/a
TCO	755,447 €/a

Motor vessels dry cargo 80 – 109 m

H₂ FC with Batteries for peak shaving.

Average ship design

Main dimensions	86 m
Main propulsion power	573 kW
Energy consumption	1,172 kWh/d

Exemplarily new system

Electric Motor	573 kW
H ₂ FC installed	344 kW
Batteries installed	344 kWh
Space requirement for pressure tanks	12 m ³ for 142 kg H ₂ at 500 bar

Weight and space requirement for batteries	3.4 t and 4.5 m ³
--	------------------------------

Cost prognosis propulsion system

H ₂ FC System CAPEX	1,583,822 €
Thereof H ₂ tank system for 2 days	113,661 €
Capital Costs	47,515 €/a
Depreciation	79,191 €/a
OPEX	147,908 €/a
TCO	255,725 €/a

Motor vessel liquid cargo 80 – 109 m

MeOH FC with Batteries for peak shaving.

Average ship design

Main dimensions	86 m
Main propulsion power	716 kW
Energy consumption	1,715 kWh/d

Exemplarily new system

Electric motor	716 kW
MeOH FC installed	430 kW
Batteries installed	430 kWh
Weight and space requirement for batteries	4.3 t and 5.7 m ³

Cost prognosis propulsion system

MeOH FC System CAPEX	1,697,121 €
Capital Costs	50,914 €/a
Depreciation	84,856 €/a
OPEX	336,256€/a
TCO	472,026 €/a

Motor vessels < 80 m length

Small motor vessels have a low energy demand and limited power installed. Therefore, they are more suitable for pure battery propulsion. This example serves for vessels mainly operating on channels.

Especially the low noise level and the zero-emissions of the battery electric propulsion are an advantage for vessels operating in urban areas. The space requirement is considered for this specific case as space is limited on this ship type.

Average ship design

Main dimensions	67 m 8.2 m 2.5 m
Main propulsion power	227 kW
Energy consumption	355 kWh/d

Exemplarily new system

Electric motor	227 kW
Batteries installed	710 kWh
Weight and space requirement for batteries	7.1 t and 9.4 m ³

Cost prognosis propulsion system

Battery system CAPEX	721,730 €
Capital Costs	21,646 €/a

Depreciation	36,067 €/a
OPEX	28,585 €/a
TCO	114,146 €/a

Coupled convoys

This example is to illustrate that even very large sized vessels are applicable for the use of a MeOH fuel cell. In addition, other technologies are even less an option since they require too much space and are even more costly either in terms of investment (batteries) or operation (hydrogen).

Average ship design

Exemplary main dimensions	Approx. 110 m+86 m
Average main propulsion power	1,678 kW
Energy consumption	4,037 kWh/d

Exemplarily new system

Electric motor	1,678 kW
MeOH FC installed	1,012 kW
Batteries installed	1,012 kWh
Weight and space requirement for batteries	10 t and 13 m ³

Cost prognosis propulsion system

MeOH FC System CAPEX	3,307,087 €
Capital Costs	99,213 €/a
Depreciation	165,354 €/a
OPEX	790,546 €/a
TCO	1,055,113 €/a

Ferries

Ferries have a low energy demand and limited power installed. Therefore, they are suitable for pure battery propulsion. In addition, the possibility is given that they recharge between the trips at the berthing point at each side of the river.

Average ship design

Main dimensions	35 m x 10 m x 1.00 m
Main propulsion power	281 kW
Energy consumption	716 kWh/d

Exemplarily new system

Electric motor	281 kW
Batteries installed	1,431 kWh
Weight and space requirement for batteries	14 t and 19 m ³

Cost prognosis propulsion system

Battery system CAPEX	915,738 €
Capital Costs	27,460 €/a
Depreciation	45,747 €/a
OPEX	54,515 €/a
TCO	136,192 €/a

Day trip and small hotel vessels

Especially day trip vessels have a very short range and usually run on fixed routes. This makes them predestined for the use of an H₂ ICE to be installed. Also, the fixed operational area offers them the possibility to always use the same bunkering installation.

The system installation cost for the H₂ ICE system is, differing from above, assumed to be 100,000 €.

Average ship design

Main dimensions

Main propulsion power 375 kW

Energy consumption 391 kWh/d

Exemplarily new system

H₂ engine 357 kW

Space requirement for pressure tank 4 m³ for 47 kg H₂ at 500 bar

Cost prognosis propulsion system

H₂ ICE system CAPEX 356,387 €

Thereof H₂ tank system for 2 days 37,887 €

Capital Costs 10,692 €/a

Depreciation 17,819 €/a

OPEX 70,369 €/a

TCO 98,880 €/a

5.4 TCO for the drivetrain for fleet families / type ships

This section presents the TCO costs for all identified fleet families. For all propulsion technologies, the costs for 2020, 2035 and 2050 are listed in Figure 36 to Figure 44. They each refer to a system consisting of several components. With the battery electric systems, the installed batteries can cover the 2-day power demand of the type ship. TCO costs include OPEX, depreciation and capital costs. As in the approach of the PROMINENT project, the fuel costs included in the OPEX costs are only for the main engine.

It is noticeable that the battery costs for 2020 are much higher than the assumptions for later dates. The same applies to fuel cell technology. This is due to the fact that these technologies are still at the beginning of a wide dissemination. A mass-rollout of the technologies is assumed to have a significant effect on the price development. A similar effect applies to PTL as it is not commonly used yet but the more wide-spread production is assumed to have a similar effect on the price. For GTL the effect is expected to be inverted, as long as the price is coupled to diesel.

It can be seen that some systems can be especially economically advantageous for some type ships. For example, the H₂ fuel cell tends to be economically advantageous for smaller ships (Figure 44), while the MeOH fuel cell fits better for larger ships (Figure 36). However, when designing a single ship, the specific case must be considered. Amongst other effects the loss of cargo space or payload is not calculated in this high-level approach for entire fleet families. These differ significantly for vessels within the same fleet family e.g. based on the transport task and waterway stretches.

It is also possible to identify some relationships between energy throughput and appropriate propulsion technology for the different type ships. The example of LNG illustrates this well: this technology can be a good alternative for a coupled convoy (Figure 45), but it is rather unsuitable for a small push boat (see Figure 37).

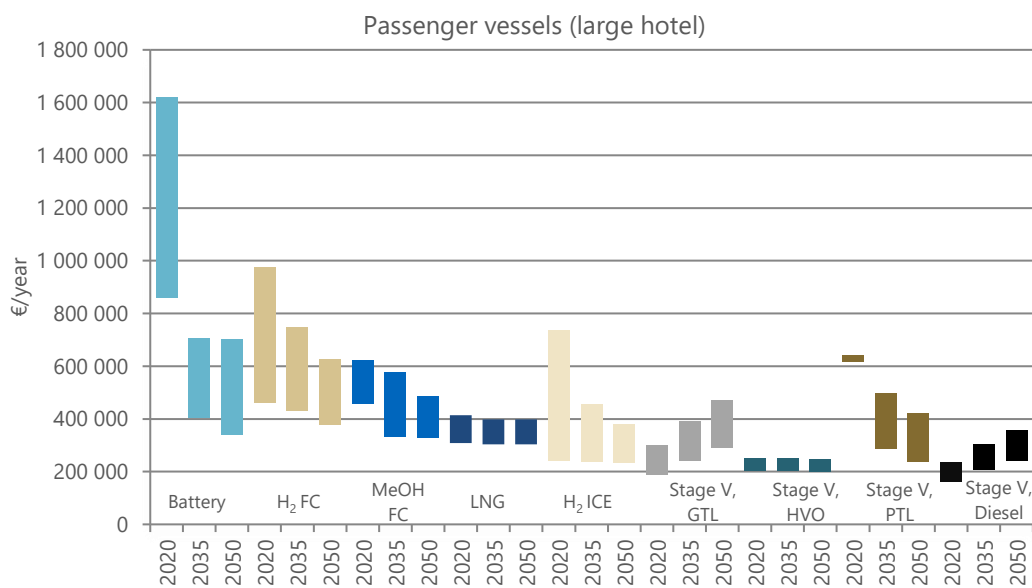

Figure 36: TCO for the type ship of the fleet family large hotel passenger vessels

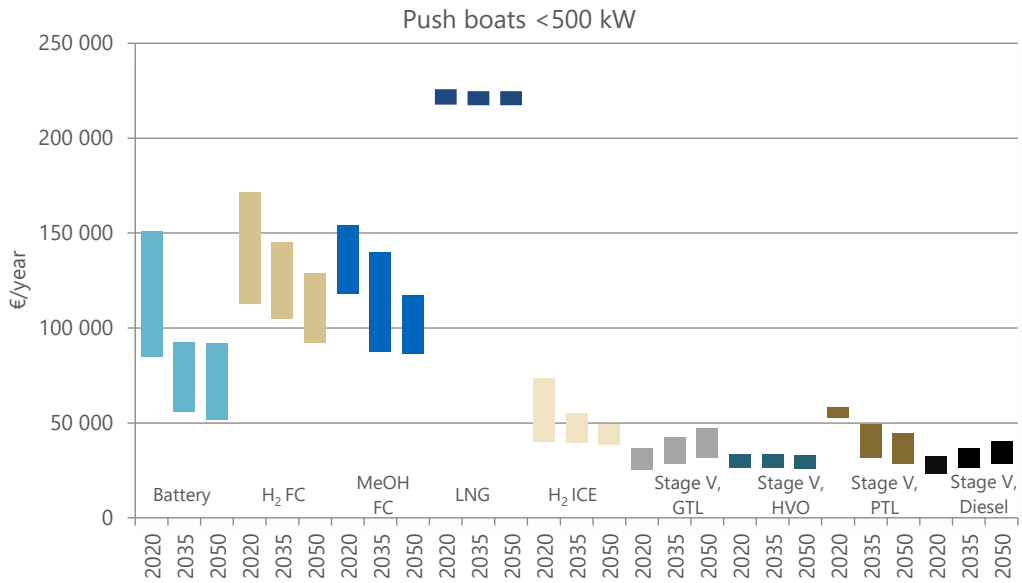

Figure 37: TCO for the type ship of the fleet family push boats with a main propulsion power of less than 500 kW

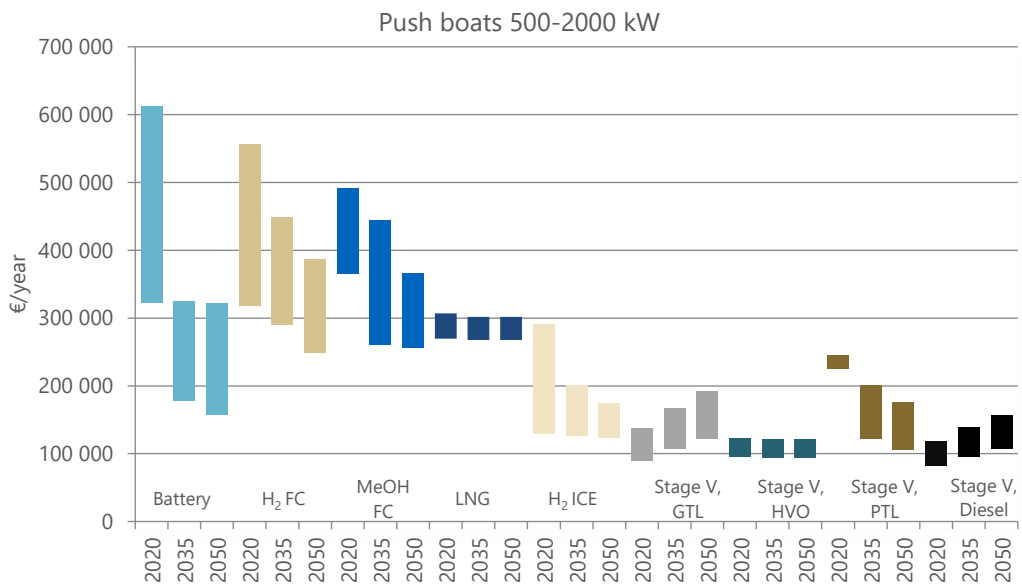

Figure 38: TCO for the type ship of the fleet family push boats with a main propulsion power between 500 kW and 2,000 kW

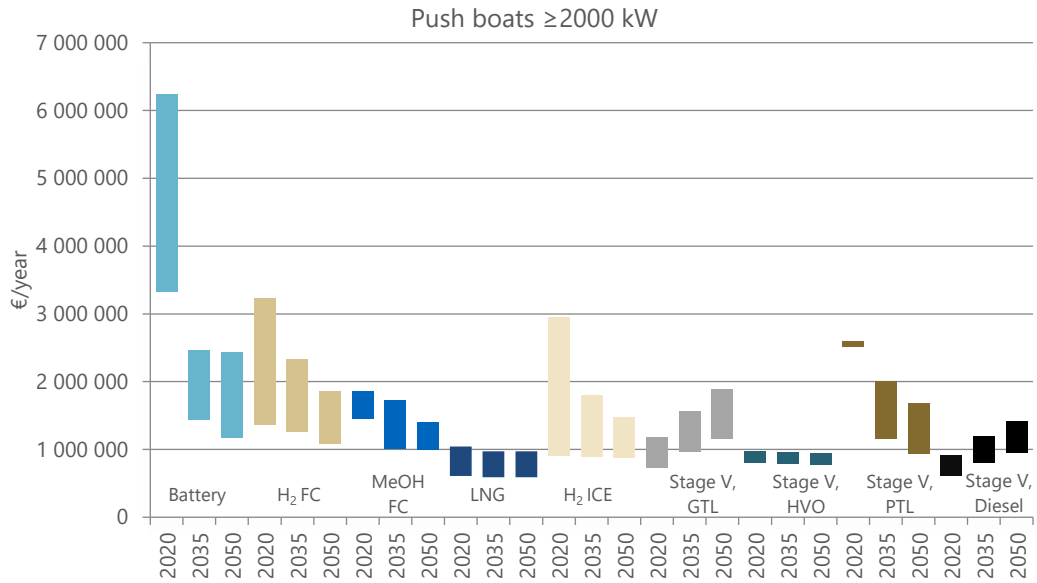

Figure 39: TCO for the type ship of the fleet family push boats with a main propulsion power of more than 2,000 kW

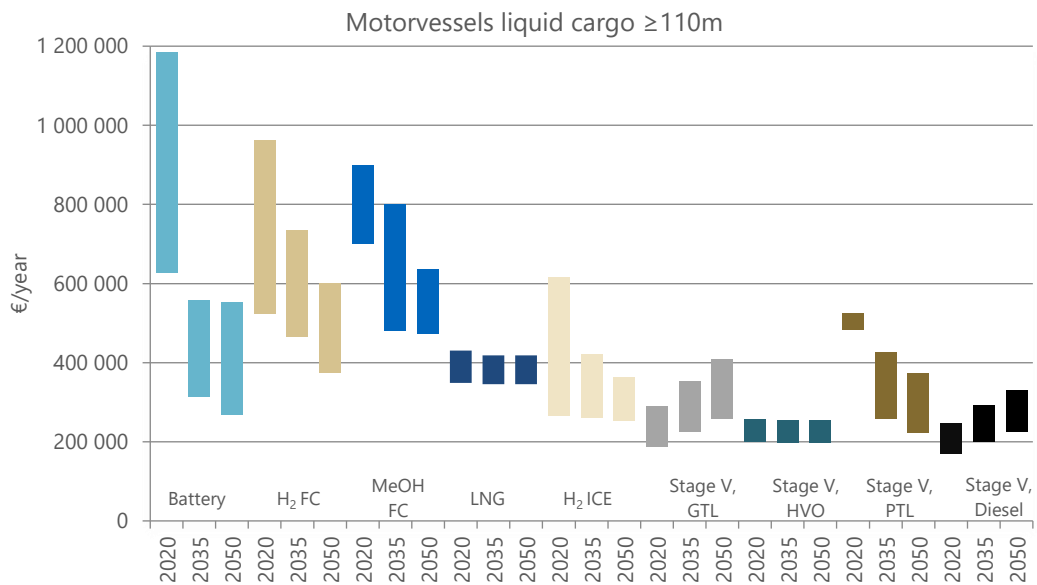

Figure 40: TCO for the type ship of the fleet family motorvessels with liquid cargo ≥ 110 m

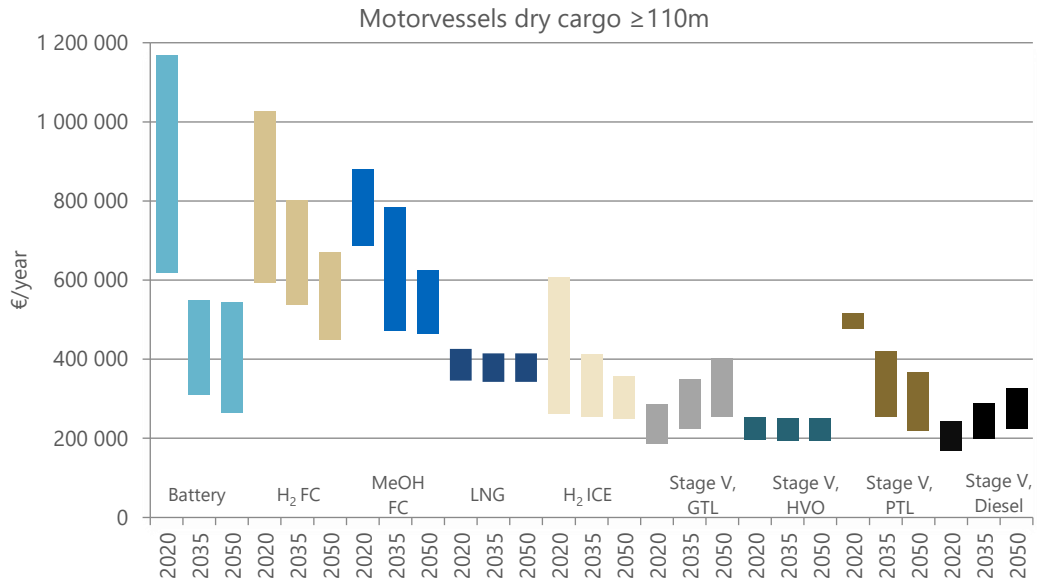

Figure 41: TCO for the type ship of the fleet family motorvessels with dry cargo $\geq 110\text{ m}$

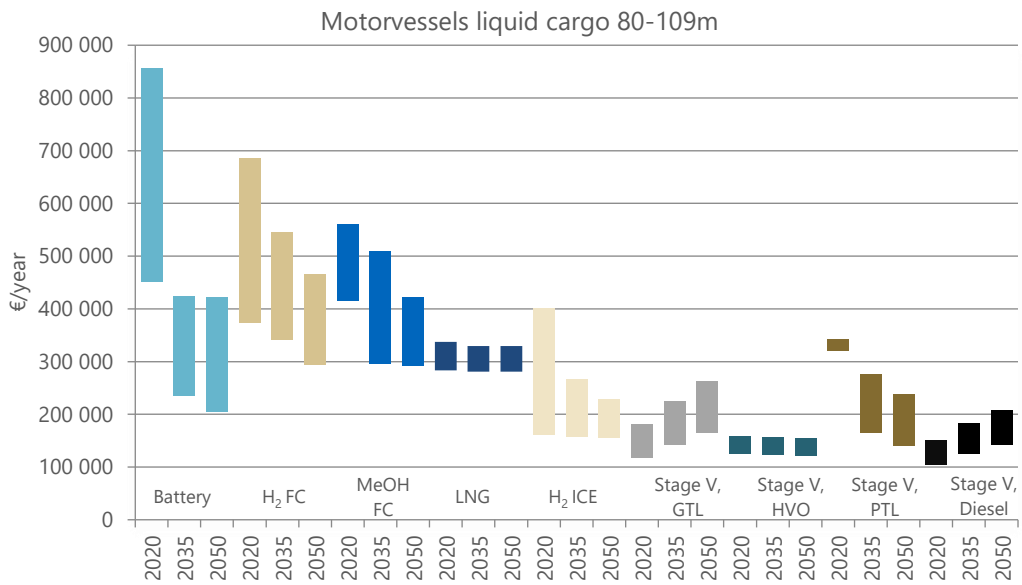

Figure 42: TCO for the type ship of the fleet family motorvessels with liquid cargo between 80 m and 109 m

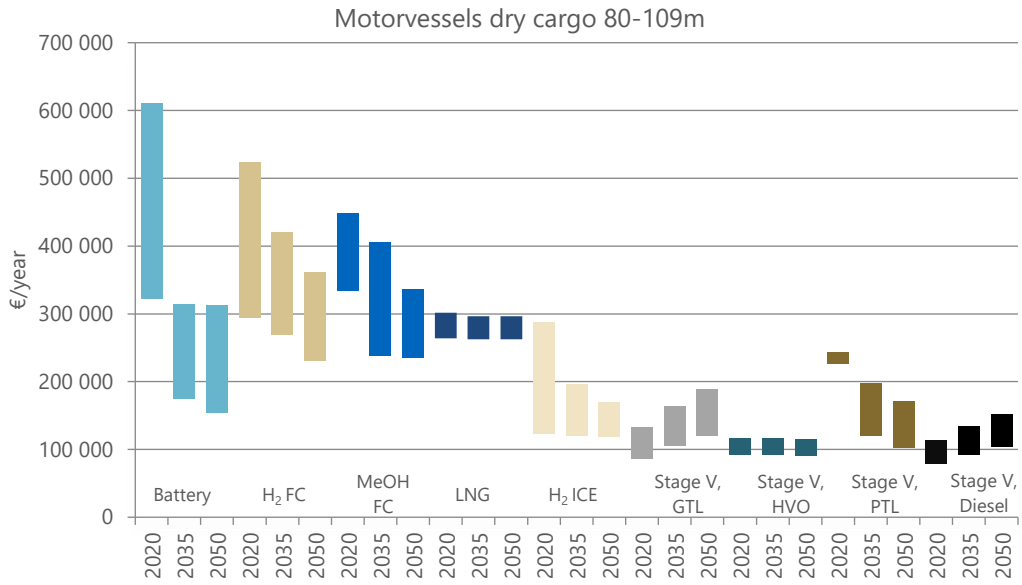

Figure 43: TCO for the type ship of the fleet family motorvessels with dry cargo between 80 m and 109 m

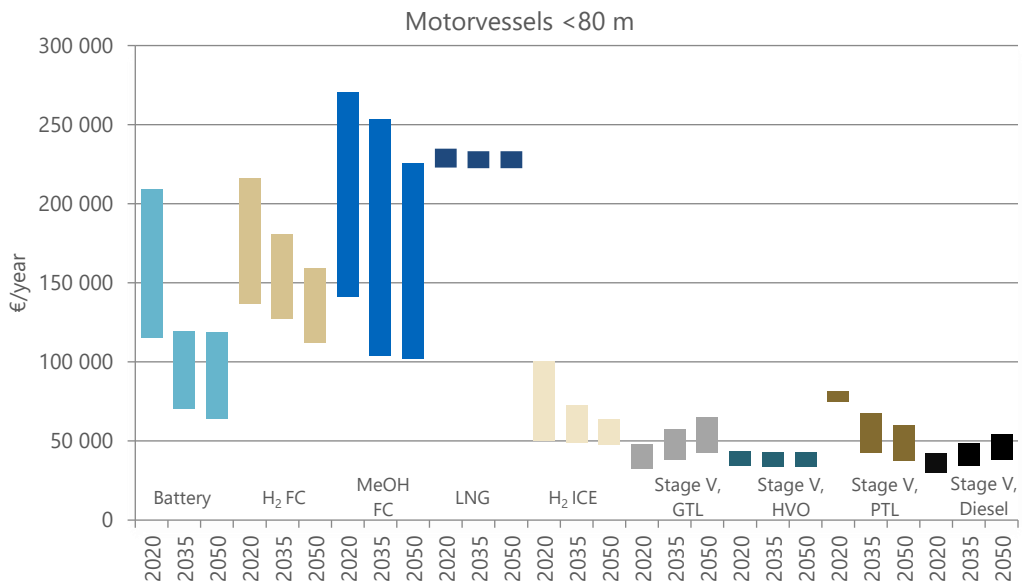

Figure 44: TCO for the type ship of the fleet family motorvessels smaller than 80 m

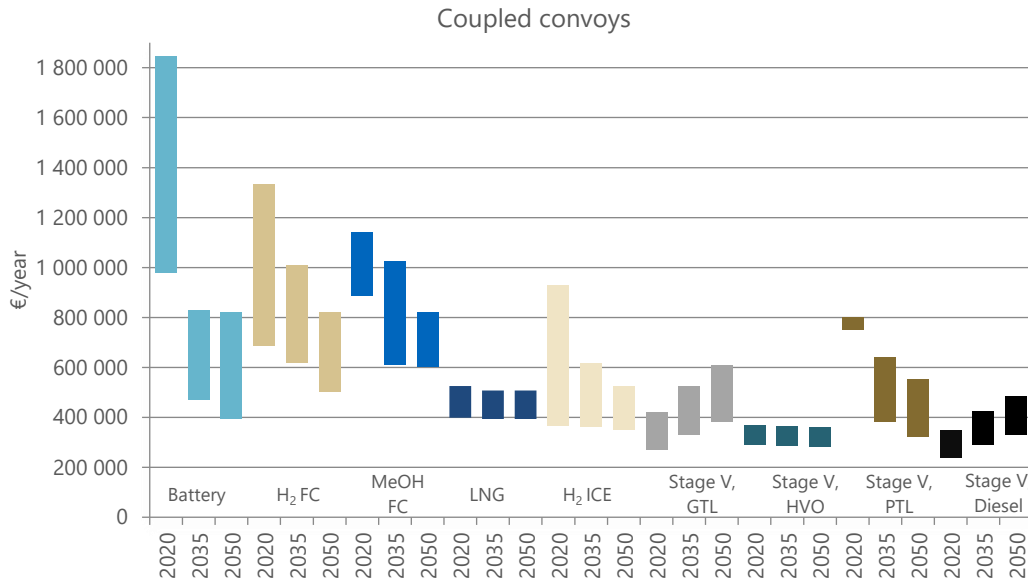

Figure 45 TCO for the type ship of the fleet family coupled convoys

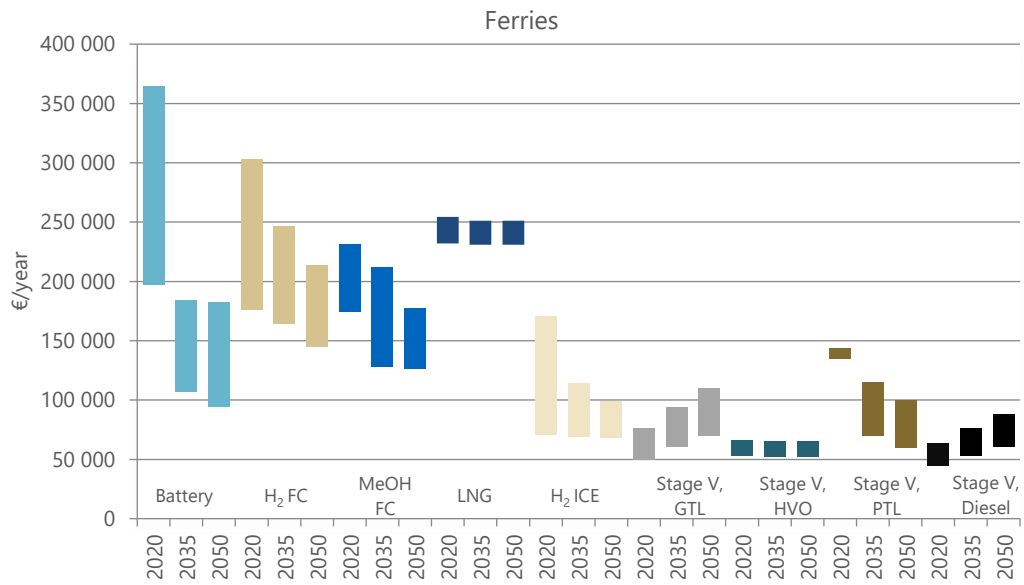

Figure 46: TCO for the type ship of the fleet family ferries

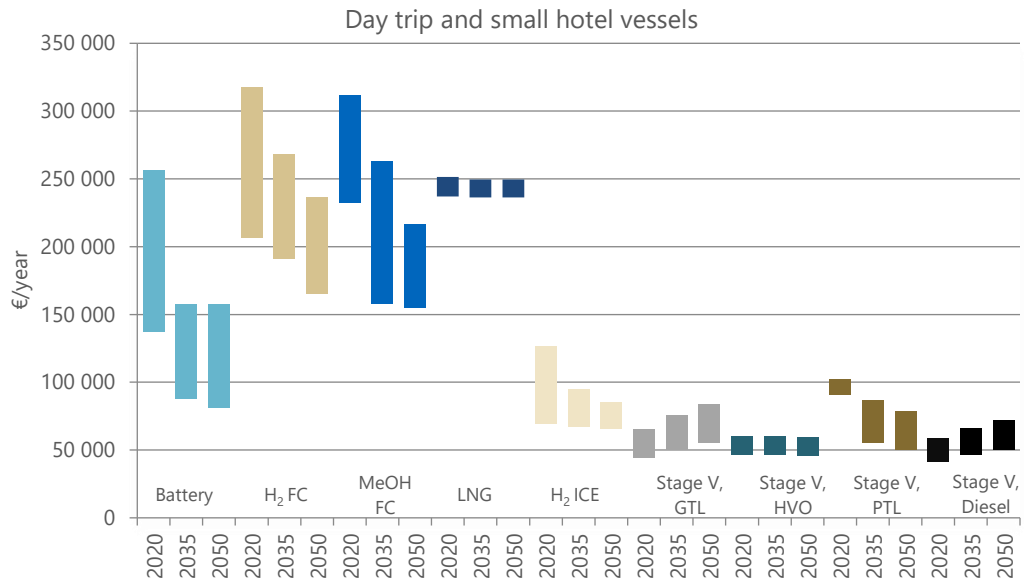

Figure 47: TCO for the type ship of the fleet family day trip and small hotel vessels

6 Transition pathways

6.1 Reduction of emissions by 35 % until 2035

According to the Mannheim Declaration [49] both the pollutant and the CO₂ emissions shall be reduced by 35 % by 2035 compared to 2015. To achieve this goal the following measures can be taken:

Pollutants: There is still a large number of unregulated engines in service. The CCNR I was put into force in 2003. This means that all unregulated engines are built before 2003. In 2035 these engines are well over 30 years old, meaning they are then written off in any case. It can also be assumed from a technical point of view that the major part of those engines is near end of lifetime, since service life is commonly given with 20 years. To reach the 35 % emission reduction it is assumed that 75 % of all unregulated engines then reach the Stage V standard by either replacement or by retrofitting an exhaust aftertreatment system. However, especially old engines might have trouble with the installation of an aftertreatment system due to low back pressure tolerance. Therefore, the option whether retrofit or replacement is done is left open. Depending on the vessel type and use, for very old engines, which are not replaced or retrofitted by the operators in reasonable time, a ban can also be a hard but appropriate measure.

If 75 % of those unregulated engines have reached their end of life and are replaced with Stage V engines until 2035, approx. 29 % of NO_x and 35 % of PM emissions could be reduced. If old engines are well maintained and the operational profile allows extended lifetime, retrofitted exhaust gas aftertreatment systems with emission levels equivalent to Stage V should be considered as well. Moreover, as all newbuilt vessels are required to conform to Stage V or even Euro VI standard, the emissions are further reduced by up to 10 % for each air pollutant for the whole fleet. It is difficult to estimate how many of these engines will be upgraded within business as usual. The calculated overall investment amounts to 0.86 billion Euro for the low, 1.02 billion Euro for the average and 1.18 billion Euro for the high price scenario.

CO₂ emission: A large number of vessels in today's fleet is not very energy-efficient. By assuming that all newbuilt vessels will be 20 % more energy-efficient (number generated from DST expertise) 11 % of CO₂ emissions can be saved for the whole fleet. The use of renewable fuels like HVO also contributes to CO₂ savings. E.g. a 30 % blend for 30 % of the fleet would lead to 9 % CO₂ savings. If these measures are taken, there are still 15 % CO₂ reductions that need to be covered.

Since not only the vessel's equipment but also the operation can contribute to emission reduction, it is recommended to take the following actions: reduction of speed, raising awareness for energy efficient navigation amongst the shipping personnel and optimization of the logistics chains. Digitalisation with track and speed advice tools for energy efficient navigation, smart tools for lock and terminal approach and efficient integration of inland vessels in sea ports can contribute to emission reductions. Increasing energy costs can be a powerful driver.

Remaining CO₂ emissions can be saved by covering a low percentage of the fleet's energy demand with zero-emission technologies such as hydrogen as fuel in either fuel cells or internal combustion engines and higher bio blends. There is also an energy efficiency potential in the existing fleet that can be used to lower CO₂ emissions.

6.2 Emission reduction target 2050

The Mannheim Declaration [49] states “to largely eliminate the greenhouse gases and other pollutants by 2050” leading to the question: “How much is largely enough?”

Achieving the 2°C target requires an 80-95 % reduction in the climate-impacting emissions of industrialised countries by 2050 [50]. From this, the 80 % and 90 % scenarios were derived. For the 1.5°C target an effort beyond that is necessary. Therefore, 98 % were assumed in order to significantly tighten up the effort and make the leap in financial expenditure clear. The 100 % reduction scenario is intended to illustrate how great the effort is to achieve absolute climate-neutrality. When this study was almost finished it was concretised, that for upcoming in-depth assessments the emission reduction target should be “at least 90 %”.

In the following, three ambition levels with the reduction of CO₂, NO_x and PM by 80 %, 90 % and 98 % are worked out. For all scenarios targeting 2050 it is no longer sufficient to equip only new buildings with zero-emission technologies. The more ambitious the scenario, the greater is the share and significance of retrofits. Alternatively, new construction activity could be increased, but this is not considered here due to the assumptions made for fleet development. On the one hand, some countries consider initiating new-build programmes for smaller cargo vessels. On the other hand, high costs for clean technologies may lead to a further decrease of investment activities in some segments. Therefore, a constant age distribution per fleet family is assumed.

For all scenarios described in the sections below a climate-neutral tank-to-wake balance is assumed for all energy carriers except LNG and GTL. This assumption is a prerequisite to achieve the scenario. Concludingly, important work is also needed from an energy supply point of view not in the scope of this research. The following Table 10 shows the achieved reductions per scenario. The scenarios with HVO contain a very high share of 100 % HVO usage in modern combustion engines (at least Stage V or equivalent) with exhaust gas aftertreatment. The scenarios not having the focus on HVO do also comprise HVO but additionally fossil fuel is still used. To get the same emission reduction this means that at the same time the share of more costly zero-emission technologies has to be increased. A general overview of all scenarios and their composition and share per technology compared to each other can be seen in Figure 48. The scenario HVO 80 % exceeds the intended reductions also for the air pollutants with a small share of zero-emission technologies in the fleet. Even a scenario where all vessels use 100 % HVO by 2050 would achieve a NO_x reduction of approximately 84 % compared to 2015. This results from a combination of the predicted reduction in energy demand due to improved efficiency of ships, drivetrains and operation in combination with the Stage V emission limits. However, the availability of HVO will remain limited by the sustainable

feedstocks and it is not likely, that the entire global HVO production is available to be used in the inland navigation sector.

Table 10: Summary of the achieved reductions per scenario

Scenario	CO ₂	NO _x	PM
HVO 80 %	100 %	86 %	98 %
80 %	84 %	87 %	98 %
HVO 90 %	100 %	91 %	98 %
90 %	92 %	91 %	99 %
98 %	98 %	97 %	99 %
100 %	100 %	100 %	100 %

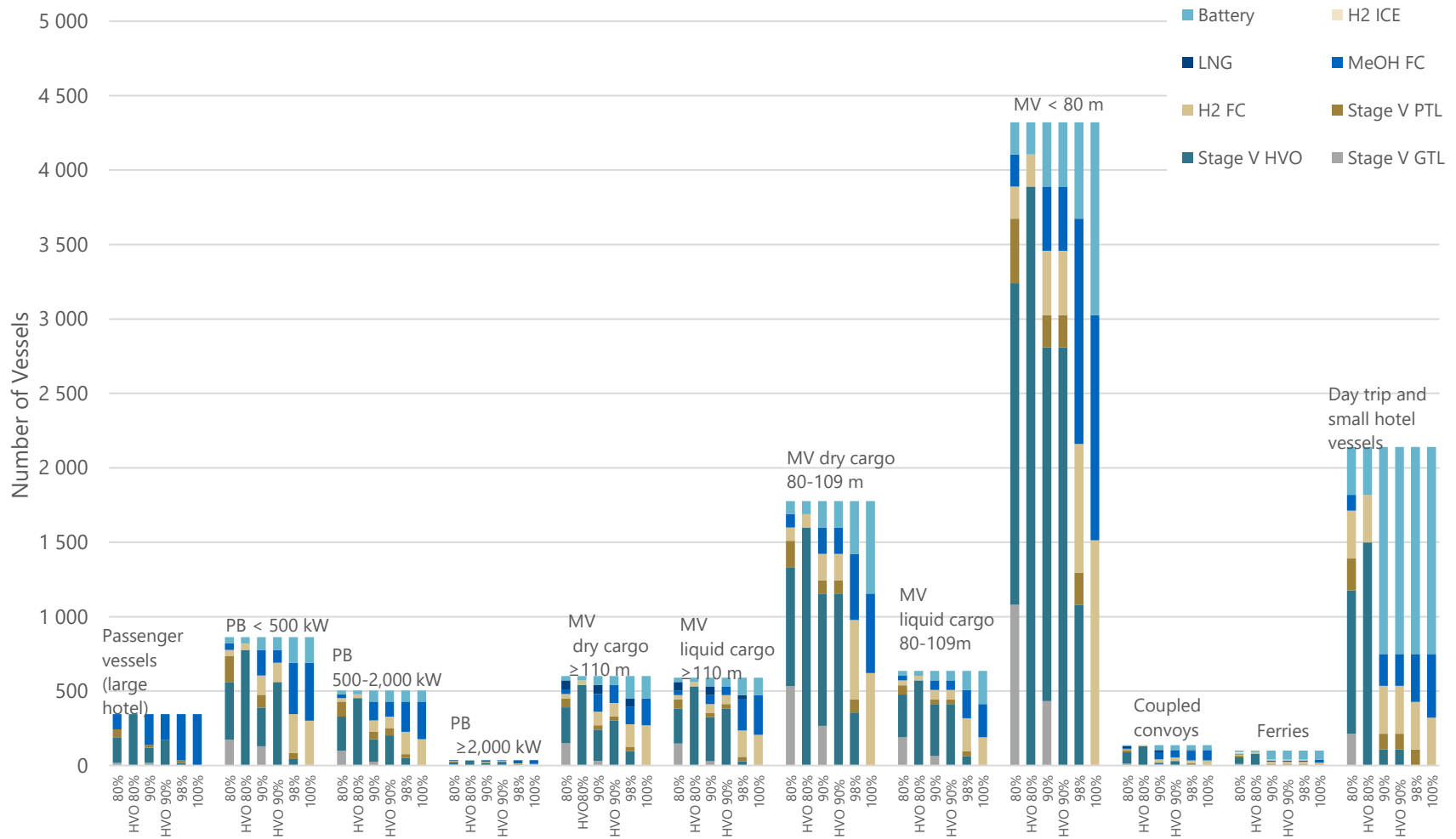

Figure 48: General overview of all scenarios

6.2.1 Scenario HVO 80 % reduction

In the scenario HVO 80 % rate of emission reduction, the vessels are powered to a large extent by engines with Stage V emission standard (or with a higher standard such as Euro VI). These engines are capable of almost completely meeting the targeted reduction of air pollutants for the entire fleet. Only small parts of the fleet are equipped with zero-emission technologies like fuel cells and batteries while the ICE is still the most common propulsion system. All fuel for this scenario must come from renewable sources and the type approvals of the engines must include paraffinic fuels according to EN15940. Only the use of HVOs and PTLs is therefore permitted, while PTL is avoided due to the significantly higher operational costs. However, the availability of sustainable feedstocks and production capacities may only be sufficient if almost all HVO is provided to the IWT sector or the capacities are increased substantially.

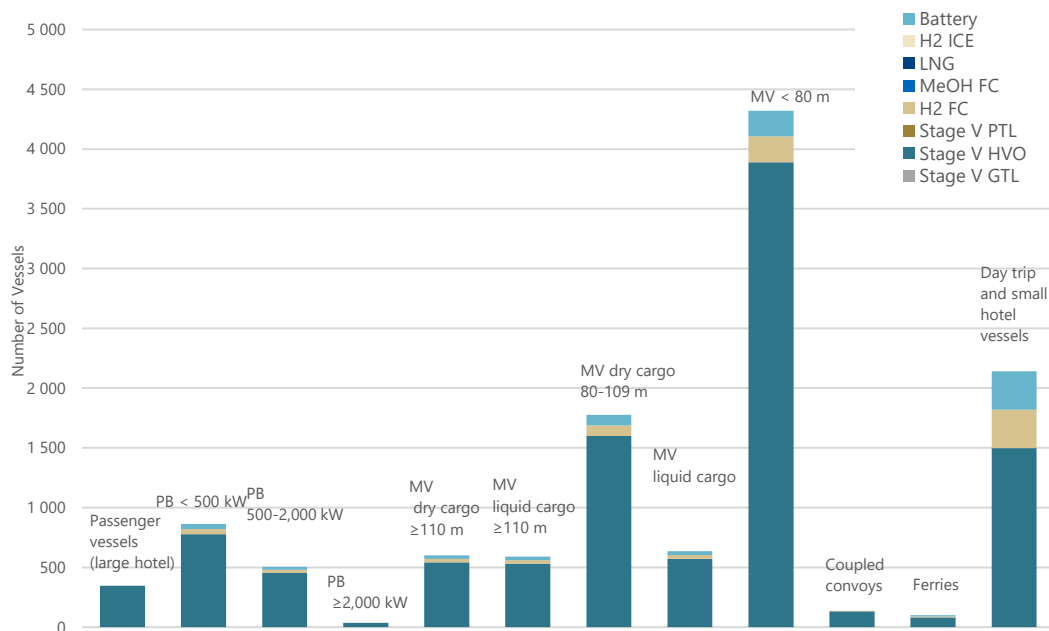

Figure 49: Technology share per fleet family in the 80 % HVO scenario

6.2.2 Scenario 80 % reduction

Within the 80 % rate of emission reduction scenario, some amounts of the fleet can still use fossil fuels to feed their ICE. However, to reach the greenhouse gas emission reduction aim, most fuel must come from renewable sources. Therefore, mainly the use of HVOs and PTLs is permitted; fossil GTL is used to a lesser extent.

In particular ferries and small day-trip vessels are suitable for the application of zero-emission technologies due to their low energy requirements and limited cruising range.

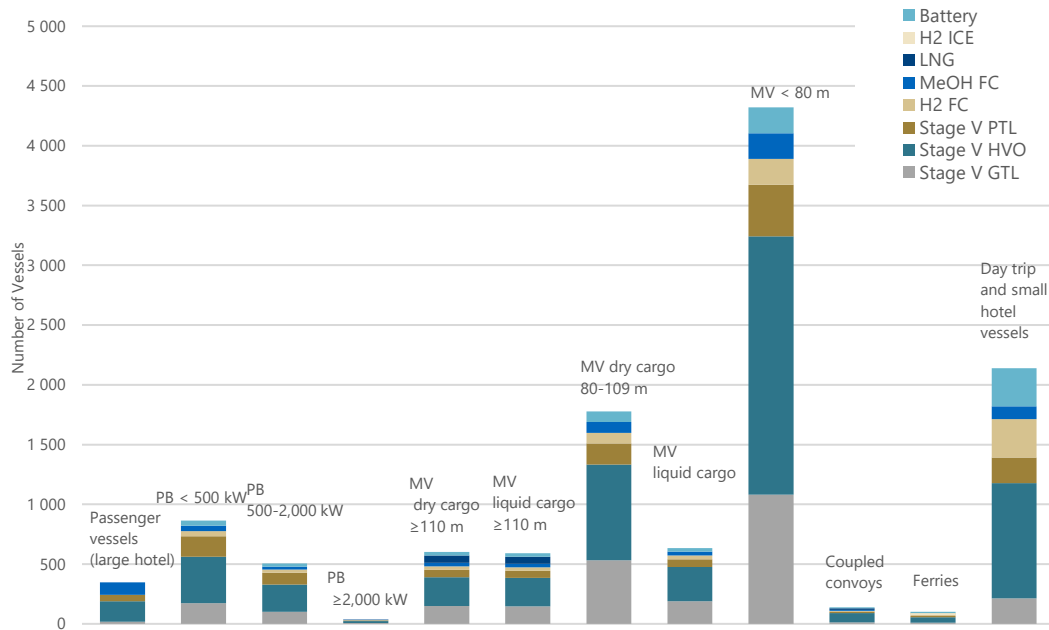

Figure 50: Technology share per fleet family in the 80 % scenario

6.2.3 Scenario HVO 90 % reduction

Within the HVO 90 % emission reduction scenario, a considerable share of the fleet is expected to be equipped with Stage V emission standard engines (and engines with a higher standard such as Euro VI). Some amounts of the fleet can still use an ICE coupled with fossil fuels for propulsion as long as it is combined with an adequate exhaust aftertreatment. However, to reach the greenhouse gas emission reduction aim, while keeping the investment costs acceptable all drop-in fuels must come from renewable sources. The use of HVOs is highly encouraged and PTLs are also permitted; fossil GTL is not used in this scenario at all.

Only a minor share of the fleet is equipped with zero-emission technologies. In particular the fleet families of ferries and small day-trip vessels are appropriate for the use of zero-emission technologies due to their low energy requirements and limited cruising range. Also, large hotel vessels are particularly useful for the application of the methanol fuel cell in combination with a battery. Although small motor vessels are expected to have more difficulties to finance zero-emission technologies like fuel cells and batteries they have to contribute to these sections as there are too many of them to otherwise successfully reach the aim.

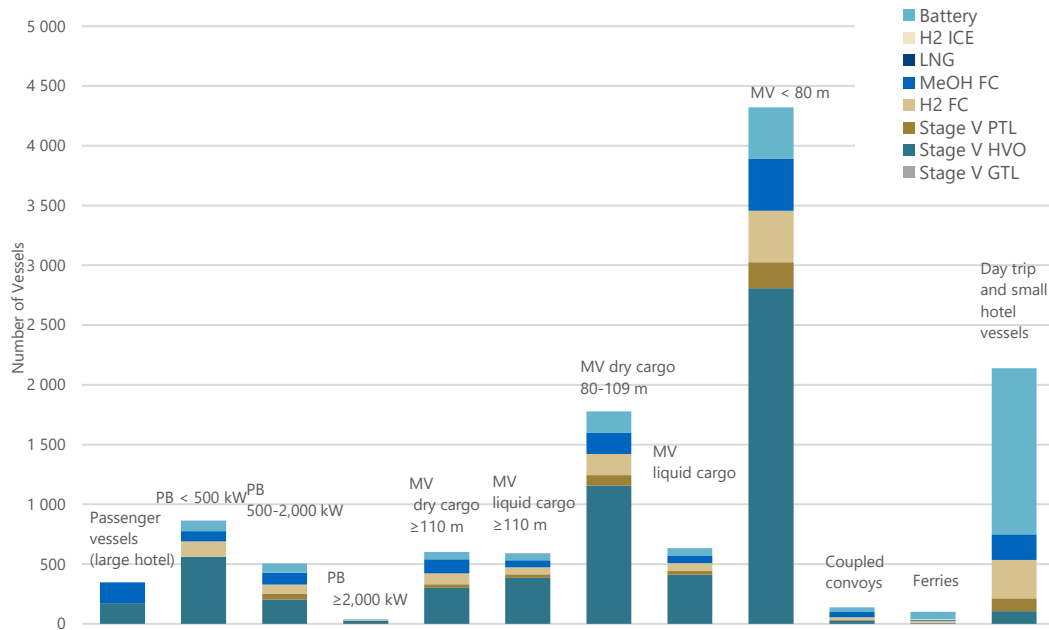

Figure 51: Technology share per fleet family in the HVO 90 % scenario

6.2.4 Scenario 90 % reduction

The alternative 90 % rate of emission reduction scenario is not mainly based on HVO as in addition the availability of larger volumes is not ensured. Still a considerable share of the fleet is expected to be equipped with Stage V emission standard engines (and engines with a higher standard such as Euro VI). Also, some amounts of the fleet can still use an ICE coupled with fossil fuels for propulsion as long as it is combined with an adequate exhaust aftertreatment. However, the investment costs for this scenario rise as more vessels are equipped with zero-emission technologies like fuel cells and batteries. There is still quite some amount of HVOs being used as well as PTLs, both permitted due to their renewable bases; fossil GTL can be used to an even lesser extent than in the 80 % scenario.

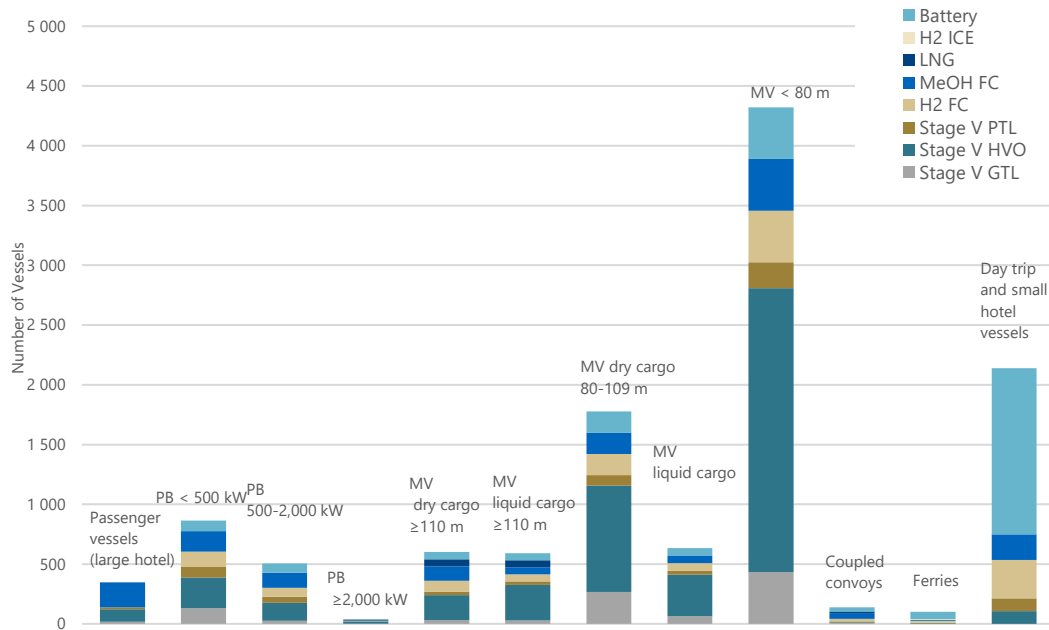

Figure 52: Technology share per fleet family in the 90 % scenario

6.2.5 Scenario 98 % reduction

Between the 98 % rate of emission reduction scenario and the 90 % scenario there is again a larger step in development the fleet has to undergo to reach the aim. It is evident that to equally reduce all emissions like also NO_x and PM even the use of fuel from renewable sources has to be lowered to a much smaller amount. Considering only CO₂ to be neutral for these alternative fuels a great portion of the vessels has to be equipped with zero-emission technologies. Up to this very moment they mainly consist of fuel cells and batteries. GTL is not playing a role anymore at all.

Still the distribution of the different technologies varies between the fleet families depending on range coupled with available space for the installation. Anyhow, there is almost no fleet family expected to be able to completely spare one or the other technology due to the lack of less space consuming or higher energy density possessing alternatives.

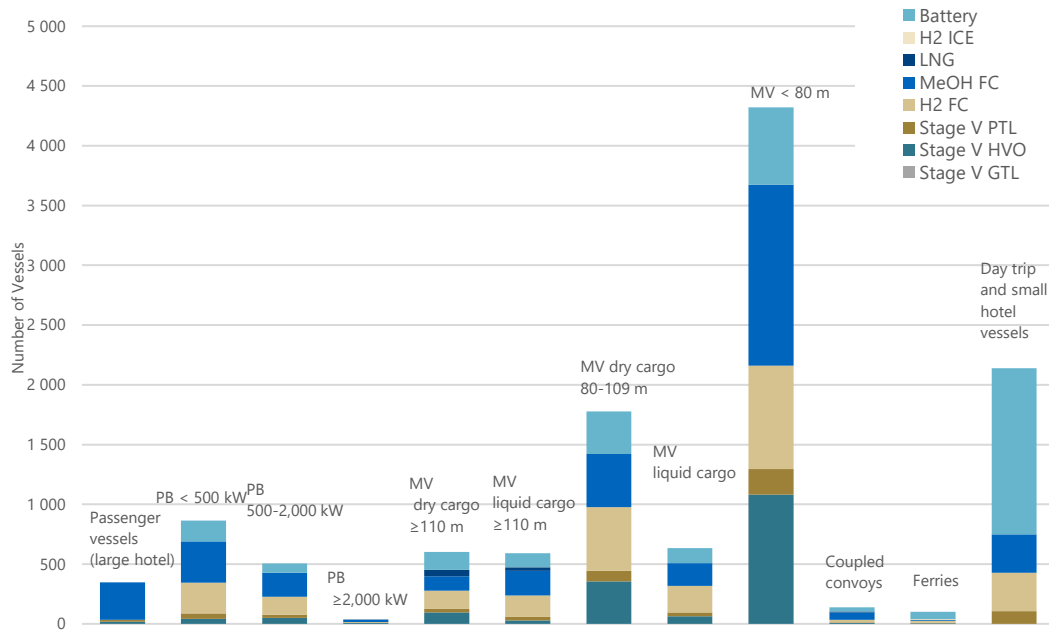

Figure 53: Technology share per fleet family in the 98 % scenario

6.2.6 Scenario 100 % reduction

Finally, within the 100 % rate of emission reduction scenario, there will be no ICE left. Only zero-emission technologies like different types of fuel cells or batteries will be applied.

There will be almost no fleet family running on but one technology only. Although large hotel vessels are expected to mainly run on methanol fuel cells in combination with a battery most other fleet family member are expected to have a wide mix of the technologies available for zero-emission operation.

What unites them all is the fact that there will be no vessel running on the same system as it is the case today. That does not mean each ship has to be a newbuild but even taking into account that quite a number of vessels are able to be converted this pathway constitutes a considerable challenge for the fleet and all related parties as well as to the environment and infrastructure of the inland waterways. At the same time there will be no one-suits-all concept designing a type ship per fleet and technology as even the members of each fleet family are to divers to allow such principle to be applied.

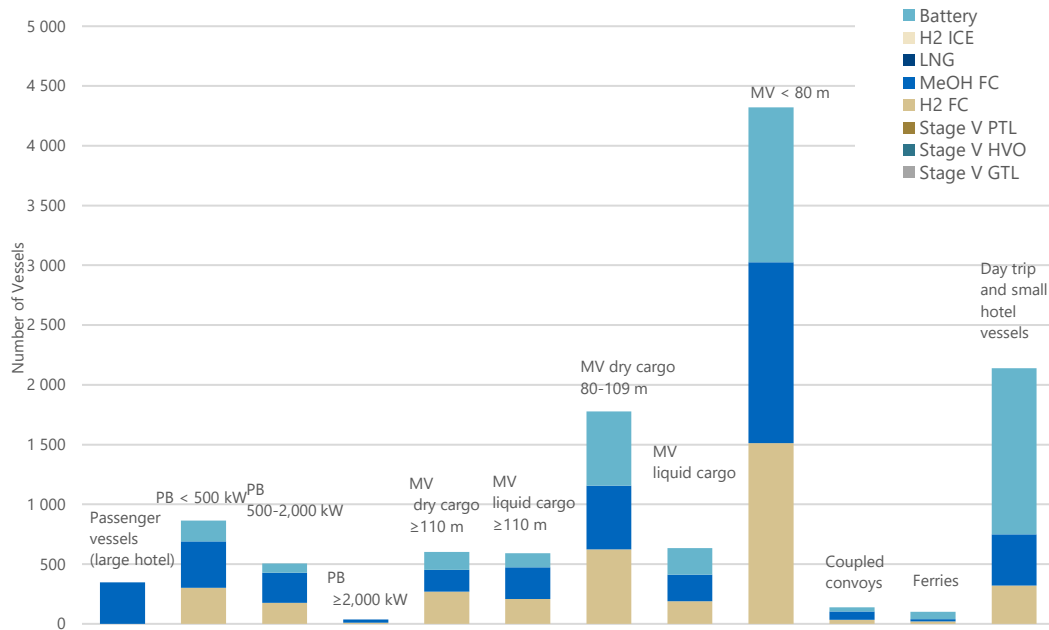

Figure 54: Technology share per fleet family in the 100 % scenario

6.3 Costs of the scenarios

The investment costs for the HVO 80 % scenario including the use of a large volume of HVOs is the scenario with the lowest investment needs. Just very few zero-emission drivetrains are included, as the reduction of air pollutant emissions is sufficient with Stage V (or equivalent) aftertreatment. However, the availability of carbon-neutral drop-in fuels will be limited and priority for use in IWT is not probable.

The investment costs for the 80 % scenario are a bit higher than for the HVO 80 % one as more vessels are equipped with zero-emission technologies to compensate for the fossil fuels still being burned. Emission reduction by 90 % already costs about twice as much, even while trying to keep the investment costs acceptable with the use of fuel from renewable sources only (scenario HVO 90 %). In the 90 % scenario the costs rise with the decreasing use of drop-in fuels from renewable sources (whose capacities free to be used by the shipping sector are still uncertain at this point) being replaced by fuel cells and batteries.

Between the 98 % scenario and the 90 % scenario there is again a larger step related to the costs. As even the use of drop-in fuel from renewable sources for combustion engines shrink to a much smaller amount now. This is due to the fact that not only CO₂ (assumed to be neutral for these alternative fuels) but also other emissions like NO_x and PM have to be equally reduced.

The 100 % scenario however, has the highest costs and is requiring the biggest change in energy supply for IWT. To get 20 % more efficient we have to spend approximately four times the amount than to get 80 % more efficient compared to 2015. The last 2 % between the 98 % and the 100 % scenario are almost as cost intensive as the whole

HVO 80 % scenario by itself. Therefore becoming 100 % emission free has to be the goal on the long term but for the goal reached by 2050 this will be highly price driven.

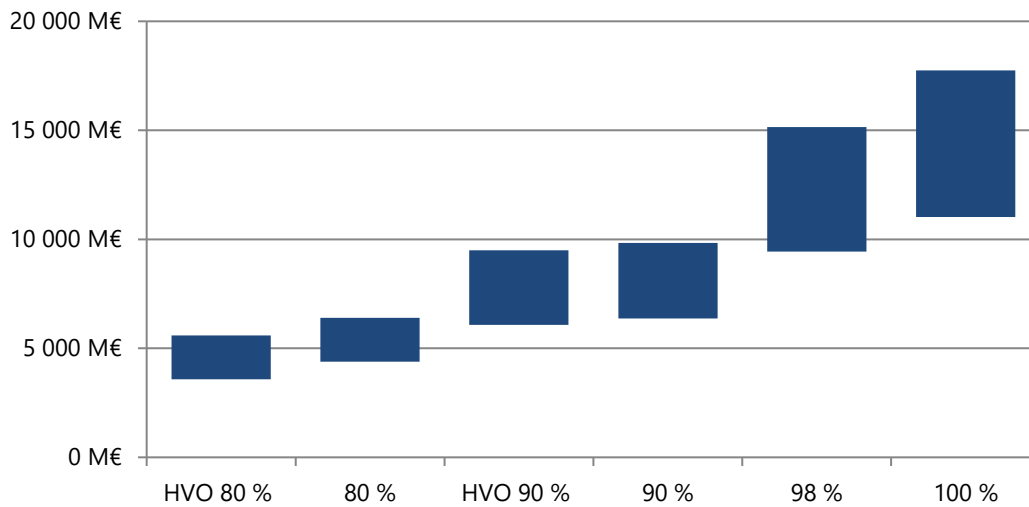

Figure 55: Cost range per scenario

For the 90 % scenario as the mean of the scenarios, with average cost figures the costs for each percent emission reduction were derived once for the reduction within the fleet family and once for the whole fleet (see Table 11). This simplified approach shows that investment is made most efficiently in vessels with the highest energy throughput. Another factor for the prioritization can be derived from the operational area. Especially, the air pollutants should be reduced first in sensitive areas like ports and stretches with a high density of population.

Table 11: Reduction costs in the 90 % scenario

	Costs per % reduction per fleet family	Costs per % reduction for the entire fleet
Passenger vessels (large hotel)	5,430,550 €	51,570,473 €
Push boats < 500 kW	2,973,806 €	171,544,218 €
Push boats 500 - 2,000 kW	5,771,437 €	115,405,605 €
Push boats ≥ 2,000 kW	1,142,783 €	25,193,836 €
Motorvessels dry cargo ≥ 110 m	11,603,052 €	92,182,000 €
Motorvessels liquid cargo ≥ 110 m	8,928,413 €	71,037,403 €
Motorvessels dry cargo 80-109 m	12,465,720 €	70,153,765 €
Motorvessels liquid cargo 80-109 m	5,611,063 €	60,116,807 €
Motorvessels < 80 m	13,603,887 €	102,198,247 €
Coupled convoys	4,559,364 €	95,883,835 €
Ferries	741,149 €	119,528,481 €
Day trip and small hotel vessels	16,433,734 €	226,539,310 €

7 Summary, Conclusions and Outlook

The study reported herein was undertaken in the context of the declaration of Mannheim and the underlying objective of emission reductions up to largely zero-emission inland shipping by 2050. First, the status quo of the European fleet and its emissions for the year 2015 was summarized on the basis of data available from the CCNR, the Danube Commission, assessments performed within the H2020 project PROMINENT and several other sources. Afterwards, energy carriers and energy conversion technologies with at least TRL 7 with their basic characteristics were described and assessed regarding applicability in the inland navigation sector. For each solution cost figures and predictions for the next 30 years were collected, filtered and compiled to optimistic, moderate and pessimistic scenarios. Other technological options like lithium-air batteries, LOHC, formic acid (hydrozine) or the use of green ammonia with appropriate crackers in combination with fuel cells or internal combustion engines might play significant roles in later stages of the energy transition. However, they have not yet reached sufficient TRL and well-founded cost figures to recommend the widespread implementation and are, therefore, not considered in the calculation.

The fleet families defined in the PROMINENT project were expanded slightly and the suitability of technologies was rated for twelve ship types. For each family a representative ship was described with a possible zero-emission system and the related investment and operational costs. Afterwards, several exemplary chains of measures for each segment of the fleet were iteratively chosen to meet the emission reduction goals by 2035 and 2050. The related investment costs for advanced drive trains were calculated for the three cost levels mentioned above. It was assumed that the age distribution in each fleet segment remains constant. Therefore, both newbuilt ships and conversions of existing vessels are considered. Especially retrofitting zero-emission technologies to older vessels is complex and requires major conversions in most cases. At the same time, it can be a cost-effective approach which need to be weighed in the light of the remaining lifespan of each vessel. Nevertheless, as it is not realistic that the fleet will be completely renewed by 2050 this aspect has to be part of the concept.

The chains of measures for 2050 were elaborated for different ambition levels of emission reduction by at least 80 %, 90 %, 98 % and complete avoidance of air pollutants and CO₂ in a tank-to-wake perspective. Air pollutants can be avoided to a large extent with combustion engines and modern aftertreatment systems. A fleet fully equipped with Stage V IWP/IWA engines would emit 79 % less NO_x and 97 % less particles compared to the 2015 baseline. With NRE or Euro VI truck engines NO_x emissions were reduced by approximately 95 %. Due to the differing test cycles for these engine types no exact numbers can be given. A future emission regulation going beyond the Stage V limits would allow further reductions also for large IWP engines.

CO₂ emissions are the most challenging part. They can be primary reduced by decreasing the energy demand with improved utilization of the vessels, slow and smart steaming with less waiting times at locks and efficient integration of IWT in sea ports. Secondary, alternative drop-in fuels with sustainable feedstock and upstream chain can

play a major role to reduce the carbon footprint. In the study HVO and PTL were considered as carbon-neutral fuels which is in line with the IPCC assumptions [19] (see also section 3.1.5). However, the availability of these fuels and the related bunkering costs are hard to predict. If other transport modes are prioritized to use these advanced bio-fuels, the resources may be insufficient for predominant use in the inland shipping sector. Costs and sustainability depend on feedstocks and green electric energy. With the efficiency measures, approximately 15 % of the energy demand may be covered by fossil fuels in 2050 to achieve 90 % CO₂ reduction.

Decarbonisation without conventional combustion engines comes with significant challenges for energy storage and much higher costs. Today the authors consider it too early to decide for one or few technologies. Further technology-neutral developments and pilot applications are required. Multiple research and development projects are running or planned. Their success regarding sustainable zero-emission solutions at feasible costs cannot be foreseen as of today.

For the relatively small sector decisive technological leaps are unlikely to happen internally. Therefore, the developments in other sectors like long-distance road haulage should be monitored. On a midterm basis, electric drives with modern combustion gensets, potentially already including a battery and/or fuel cell to avoid emissions in ports and urban areas and future proof power management can be considered as a precursor for the later implementation of affordable zero-emission power sources. Since the retrofitting of existing vessels often requires extensive and costly conversions, the focus for advanced drivetrains should be on newbuilds. To equip many fleets with clean systems in a relatively short time, it is recommended to prepare for and use standardized systems, e.g. battery containers or fuel cells and hydrogen storage in container modules.

When an engine needs to be replaced on an existing ship, some of these vessels will not operate until 2050 and the environmental performance is significantly increased with a right-sized Stage V engine ready for the use of drop-in fuels. A long-term roadmap for the implementation of these second and third generation biofuels and blends is required. Engine suppliers have to include them in their fuel directives and production capacities need to be increased.

Given the long lifecycles in the sector the transition should be started as soon as possible while the legal framework, the market parameters and the cost structures will hardly bring the required momentum. Therefore, the studies “Financing the energy transition towards a zero-emission European IWT sector” are an important step to prepare the Europe-wide coordination.

8 Bibliography

- [1] R. D. Lasco et al., "2006 IPCC Guidelines for National Greenhouse Gas Inventories, Chapter 5 CROPLAND," 2006.
- [2] National administrations, "IVR Database".
- [3] WSV, „Altersstruktur der deutschen Binnenflotte,“ 2016.
- [4] Danube Commission, "Danube Commission market observation report," 2018.
- [5] B. Kelderman, B. Friedhoff, T. Guesnet, B. Holtmann, R. Kaiser, M. Eppich, R. Rafael, N. Dasburg, R. Liere, M. Quispel, G. Maierbrugger and J. Schweighofer, *PROMINENT - D1.1 List of operational profiles and fleet families*, 2016.
- [6] F. Dahlke und B. Friedhoff, „Energieträger für die Binnenschifffahrt von Morgen,“ in *Jahrbuch der Schiffbautechnischen Gesellschaft*, 2018.
- [7] VDMA, "Abgasgesetzgebung Diesel- und Gasmotoren," 2011.
- [8] P. Mensch, D. Abma, R. Verbeek and W. Hekman, "D5.7 Technical evaluation of procedures for Certification, Monitoring & Enforcement," 2017.
- [9] IAKS, "Bericht der IAKS über die jährliche Bewertung des Finanzierungssystems und Vorschlag für den Betrag der Entsorgungsgebühr 2019 (CDNI)," 2019.
- [10] MariGreen, "Perspectives for the Use of Hydrogen as Fuel in Inland Shipping, 2018," <https://www.dst-org.de/wp-content/uploads/2018/11/Hydrogen-Feasibility-Study-MariGreen.pdf>.
- [11] E. A. Brohi, "Ammonia as fuel for internal combustion engines?," 2014.
- [12] H. Matschiner, "Nutzung von Ammoniak zu Energieerzeugung," in *Fachtagung Möglichkeiten des Betriebs von Brennstoffzellen mit Verbrennungsgas*, Magdeburg, 2007.
- [13] K. Kugler, A. Mitsos, G. Wang and M. Wessling, "Ammoniaksynthese 2.0 – Elektrochemie versus Haber Bosch Ergebnisse einer Prozesssimulation," 2015.
- [14] Institute for Sustainable Process Technology, "Power to Ammonia - Feasibility Study for the value chains and business cases to produce CO₂-Free ammonia suitable for various market applications," 2017.
- [15] A. Valera-Medina, et al., "Ammonia for power," *Progress in Energy and Combustion Science*, vol. 69, 2018.
- [16] International DME Association, *Simple, Available, Sustainable, Low-Emission, Infrastructure Compatible Fuel*, <https://www.aboutdme.org>, 2020.
- [17] FLEDGED, *Flexible Dimethyl Ether Production from Biomassgasification with Soproption Enhanced Process*, <http://www.fledged.eu>, 2020.
- [18] EUROMOT, "FAQ / Guidance notes," 2020.
- [19] DNVGL, "2019 ENERGY TRANSITION OUTLOOK A global and regional forecast to 2050," 2019.
- [20] C. Davies Waldron, et al., "2006 IPCC Guidelines for National Greenhouse Gas Inventories, Chapter 3 MOBILE COMBUSTION," 2006.

- [21] Neste Corporation, "Neste Renewable Diesel Handbuch," 2016.
- [22] Arbeitsgruppe 2: Alternative Antriebe und Kraftstoffe für nachhaltige Mobilität, Elektromobilität, Brennstoffzelle, "Elektromobilität, Brennstoffzelle, alternative Kraftstoffe - Einsatzmöglichkeiten aus technologischer Sicht," 2019.
- [23] IRENA, "Production of Bio-methanol: Technology Brief," 2013.
- [24] European Union, "REGULATION (EU) 2016/1628 OF THE EUROPEAN PARLIAMENT AND OF THE COUNCIL of 14 September 2016 on requirements relating to gaseous and particulate pollutant emission limits and type-approval for internal combustion engines for non-road mobile machinery, amending Regulations (EU) No 1024/2012 and (EU) No 167/2013, and amending and repealing Directive 97/68/EC," 2016.
- [25] S. Cornelis, "Do gas trucks reduce emissions?," 2019.
- [26] ICCT, "EUROPEAN STAGE V NON-ROAD EMISSION STANDARDS," 2016.
- [27] H. Stellmach, "Deutz baut Wasserstoff-Verbrennungsmotor," *B_I baumagazin*, 2020.
- [28] H. Eichsleder and M. Klell, *Wasserstoff in der Fahrzeugtechnik*, Vieweg+Teubner, 2010.
- [29] Keyou Website, 2020.
- [30] Central Commission for the Navigation of the Rhine, "Possibilities for reducing fuel consumption and greenhouse gas emissions from inland navigation," 2012.
- [31] K. Baes, "Future of batteries," 2018.
- [32] L. Goldie-Scot, "A Behind the Scenes Take on Lithium-ion Battery Prices," 2019.
- [33] I. Tsiropoulos, D. Tarvydas and N. Lebedeva, "Li-ion batteries for mobility and stationary storage applications Scenarios for costs and market growth," 12 2018.
- [34] DST, "E-Binnenschiff Online Tool," [Online]. Available: dst-org.de/e-binnenschiff/.
- [35] S. S. Marc Castedello, "Cost of Capital Study 2018," 2018.
- [36] J. Hobohm, A. A. der Maur, H. Dambeck, D. A. Kemmler, S. Koziel, S. Kreidelmeyer, D. A. Piégsa and P. Wendring, "Status und Perspektiven flüssiger Energieträger in der Energiewende," 2018.
- [37] M. Kaltschmitt, H. Hartmann and H. Hofbauer, *Energie aus Biomasse*, Springer Berlin Heidelberg, 2009.
- [38] W. Maus, *Zukünftige Kraftstoffe*, Springer Vieweg, 2019.
- [39] D. Unruh, M. Rohde and G. Schaub, "Fischer-Tropsch Synthese von Kohlenwasserstoffen ausgehend von Biomasse –In-situ H₂O-Abscheidung und Verbesserung der Kohlenstoff-Nutzung," 2003.
- [40] Audi, "Audi e-gas Projekt," 2016.
- [41] German Environment Agency, "Power-to-Liquids Potentials and Perspectives for the Future Supply of Renewable Aviation Fuel," 2016.
- [42] J. A. Ryste, "Comparison of Alternative Marine Fuels," 2019.

- [43] M. Zapf, *Stromspeicher und Power-to-Gas im deutschen Energiesystem*, Springer Fachmedien Wiesbaden, 2017.
- [44] IEA, "The future of hydrogen," 2019.
- [45] IEA, "World Energy Outlook 2019," Paris, <https://www.iea.org/reports/world-energy-outlook-2019>, 2019.
- [46] EA-ETSAP and IRENA, *Production of Bio-Methanol*, 2013.
- [47] Central Commission for the Navigation of the Rhine, "Jahresbericht 2018, Europäische Binnenschifffahrt, Marktbeobachtung," 2019.
- [48] N. Pavlenko, B. Comer, Y. Zhou, N. Clark and D. Rutherford, "The climate implications of using LNG as a marine fuel," *ICCT WORKING PAPER 2020-02*, 2020.
- [49] Central Commission for the Navigation of the Rhine, *Mannheim Declaration "150 years of the Mannheim Act – the driving force behind dynamic Rhine and inland navigation"*, 2018.
- [50] Schellnhuber, H.J. et al. , "Kassensturz für den Weltklimavertrag – Der Budgetansatz (Sondergutachten)," Wissenschaftlicher Beirat der Bundesregierung Globale Umweltveränderungen (WBGU), Berlin, 2009.
- [51] M. Zapf, *Stromspeicher und Power-to-Gas im deutschen Energiesystem*, Springer Fachmedien Wiesbaden, 2017.
- [52] G. Zachmann, M. Holtermann, J. Radeke, M. Tam, M. Huberty, D. Naumenko and A. Ndoye, *The great transformation: decarbonising Europe's energy and transport systems*, 2020.
- [53] P. Kurzweil and O. K. Dietlmeier, *Elektrochemische Speicher*, Springer Fachmedien Wiesbaden, 2015.
- [54] M. Klell, H. Eichlseder and A. Trattner, *Wasserstoff in der Fahrzeugtechnik*, Springer Fachmedien Wiesbaden, 2018.
- [55] IRENA, *Global Renewables Outlook: Energy transformation 2050*, IRENA, 2020.
- [56] M. Fröba, "Wasserstoff als Energiespeicher - Vorkommen, Darstellung und Nutzung," 2014.
- [57] L. Bauer, "Methanol and Bio-economy: Now and the Future," 2017.
- [58] P. Gerbert et al., "Klimapfade für Deutschland," 2018.
- [59] CESNI and EUROMOT, "Frequently asked questions about Regulation (EU) 2016/1628," 2019.
- [60] "Final Report Summary - JOULES (Joint Operation for Ultra Low Emission Shipping)," Grant agreement ID: 605190, 2017.
- [61] European Union, *Directive 2014/94/EU of the European Parliament and of the Council of 22 October 2014 on the deployment of alternative fuels infrastructure Text with EEA relevance*, 2014.
- [62] Bundesverband der Deutschen Binnenschifffahrt e.V, *Daten & Fakten 2015/2016*, 2016.
- [63] Danube Commission, "DANUBE NAVIGATION STATISTICS in 2014-2015," 2016.

- [64] B. Friedhoff, D. Abma, P. V. Mensch, R. Verbeek, A.-C. Schulz and A. Lutz, “Digital solutions for environmental performance and efficient navigation using on-board monitoring and river modelling,” 2018.
- [65] European Union, *The European Green Deal*, 2020.
- [66] DST, “GRENDDEL Fact Sheets on Greening Technologies,” 2020.
- [67] M. Quispel et al., *D 6.7 Assessment, Recommendation and Roadmap*, 2018.

Study consortium:



In partnership with:



Throughout the project there were exchanges with the CCNR, the steering Committee composed of representatives of CCNR member States and a stakeholder group consisting of :

European Commission (DG MOVE)
Danube Commission
Mosel Commission
European Investment Bank (EIB)
European Investment Advisory Hub (EIAH)

Clinsh
European Barge Union (EBU)
European Federation of Inland Ports (EFIP)
European Shippers' Council (ESC)
European Skippers Organisation (ESO)
IWT platform
Shipyards and maritime equipment association of Europe (SEA Europe)
Association for inland navigation and navigable waterways in Europe (VBW)

Imprint: October 2020

*Published by the Central Commission for the Navigation of the Rhine (CCNR)
2, place de la République - CS10023 - F-67082 Strasbourg Cedex*

